

# MtechThesis

*by* Ankur Nigam

---

**Submission date:** 21-Jun-2026 07:32PM (UTC+0530)

**Submission ID:** 2986944152

**File name:** LatestThesis.pdf (1.66M)

**Word count:** 11387

**Character count:** 64272

# **DETECTION OF CONGESTIVE HEART FAILURE USING MULTI-LEAD ECG SIGNAL ANALYSIS**

A PROJECT REPORT

SUBMITTED IN PARTIAL FULFILLMENT OF THE  
REQUIREMENTS FOR THE AWARD OF THE DEGREE

OF

MASTER OF TECHNOLOGY

IN

COMPUTER SCIENCE & ENGINEERING

Submitted by

**ANKUR NIGAM**

**24/CSE/15**

Under the Supervision of

**Dr. Rajesh Kumar Yadav**

Associate Professor, Department of Computer Science & Engineering  
Delhi Technological University



**DEPARTMENT OF COMPUTER SCIENCE & ENGINEERING**

**DELHI TECHNOLOGICAL UNIVERSITY**

(Formerly Delhi College of Engineering)  
Bawana Road, Delhi-110042, India

**MAY, 2026**



**DELHI TECHNOLOGICAL UNIVERSITY**  
(Formerly Delhi College of Engineering)  
Shahbad Daultapur, Main Bawana Road, Delhi-110042

---

### **ACKNOWLEDGEMENT**

I sincerely thank my supervisor, Dr. R. K. Yadav, Associate Professor, Department of Computer Science & Engineering, Delhi Technological University, for guiding this project from its initial idea to its final form. His suggestions helped me refine the problem statement, understand ECG-based diagnosis more clearly, and improve the experimental presentation of this work.

I also thank the faculty members, technical staff, and academic environment of the Department of Computer Science & Engineering for providing the support required to complete this dissertation. The coursework and discussions during the M.Tech. Computer Science & Engineering programme helped me connect signal processing concepts with machine learning methods used in this study.

This work uses publicly available ECG resources, especially the BIDMC Congestive Heart Failure Database and the MIT-BIH Normal Sinus Rhythm Database. I acknowledge the researchers and institutions who made these datasets available, as such resources make reproducible biomedical research possible.

I am also thankful to my classmates, friends, and family members for their encouragement during the project. Their patience and support helped me remain consistent throughout the preparation, implementation, and writing stages of this dissertation.

Place: Delhi

ANKUR NIGAM

Date:

24/CSE/15



**1**  
**DELHI TECHNOLOGICAL UNIVERSITY**  
(Formerly Delhi College of Engineering)  
Shahbad Daulatpur, Main Bawana Road, Delhi-110042

---

### **CANDIDATE'S DECLARATION**

I, **Ankur Nigam**, Roll No. **24/CSE/15**, a student of M.Tech. Computer Science & Engineering, declare that the dissertation titled "**Detection of congestive heart failure using multi-lead ECG signal analysis**" has been prepared by me as part of the requirements of Delhi Technological University. The work presented in this report is based on my own study, implementation, analysis, and writing, and all external material used for reference has been duly acknowledged through citations.

**20**  
I further declare that this dissertation has not been submitted earlier, either fully or partially, for the award of any degree, diploma, fellowship, associateship, or equivalent academic recognition at this or any other institution.

Place: Delhi

**Ankur Nigam**

Date:

**24/CSE/15**

This is also certified that the revisions and suggestions communicated during evaluation have been addressed by the candidate, and the declaration made above is accepted to the best of our knowledge.

**Signature of Supervisor**

**Signature of External Examiner**



**DELHI TECHNOLOGICAL UNIVERSITY**  
(Formerly Delhi College of Engineering)  
Shahbad Daulatpur, Main Bawana Road, Delhi-110042

---

### **CERTIFICATE**

This certificate confirms that ANKUR NIGAM, Roll No. 24/CSE/15, Department of Computer Science & Engineering, Delhi Technological University, has completed the project dissertation titled **“Detection of congestive heart failure using multi-lead ECG signal analysis”** under my supervision. The dissertation is submitted toward the requirements for the Master of Technology degree in Computer Science & Engineering.

Based on the work reviewed by me, the dissertation presents the student’s project study, implementation, and analysis. To the best of my knowledge, the same work has not been submitted elsewhere, in full or in part, for any degree or diploma.

Place: Delhi

Date:

**Dr. R. K. Yadav**  
Associate Professor

## ABSTRACT

Congestive heart failure (CHF) reduces the ability of the heart to maintain adequate circulation and is associated with reduced physical capacity, repeated clinical follow-up, and increased cardiac risk. Since ECG recording is non-invasive, inexpensive, and suitable for repeated acquisition, it offers a practical signal source for automated CHF screening. A multi-lead ECG is particularly useful because each lead captures the same cardiac activity from a different electrical viewpoint. This dissertation studies CHF detection using a multi-lead diagnostic attention-based recurrent neural network (MLDA-RNN). The work uses the BIDMC Congestive Heart Failure Database and the MIT-BIH Normal Sinus Rhythm Database, with patient-wise separation so that test subjects are not seen during training. Integer Haar Wavelet Transform is used to obtain compact signal representations before sequence modelling. On the blind test partition, the MLDA-RNN model achieved an accuracy of 96.06%. The result indicates that combining patient-wise evaluation, multi-lead representation, recurrent learning, attention-based weighting, and efficient wavelet processing can support reliable ECG-based CHF screening. The proposed pipeline may be extended toward decision-support, remote monitoring, and wearable ECG applications after validation on broader clinical data.

# CONTENTS

<b>Acknowledgement</b>	<b>i</b>
<b>Candidate's Declaration</b>	<b>ii</b>
<b>Certificate</b>	<b>iii</b>
<b>Abstract</b>	<b>iv</b>
<b>List of Figures</b>	<b>vii</b>
<b>List of Tables</b>	<b>viii</b>
<b>1 Introduction</b>	<b>1</b>
1.1 Background	1
1.1.1 Congestive Heart Failure	1
1.1.2 Electrocardiogram Signals (ECG Signals)	2
1.2 Clinical and Technical Background	2
1.2.1 Need for Automated CHF Detection	3
1.2.2 Challenges in ECG Based Classification	4
1.3 Research Motivation	5
1.4 Organization Of The Report	6
<b>2 Review of Prior Works</b>	<b>7</b>
2.1 Literature Review	7
2.2 Datasets Used	8
2.2.1 MIT-BIH Normal Sinus Rhythm Database	8
2.2.2 BIDMC Congestive Heart Failure Database	10
2.3 Dataset Preparation and Study Design	10
2.3.1 Patient-wise Data Separation	10
2.3.2 Signal Preprocessing	11
2.3.3 Segmentation Strategy	11
2.3.4 Feature Representation	12

<b>3</b>	<b>Algorithms and Models used for detection of CHF</b>	<b>13</b>
3.1	Wavelet Transform . . . . .	13
3.1.1	Mallat’s Algorithm . . . . .	14
3.1.2	Integer Haar Transform (IHT) . . . . .	14
3.2	Methodology Used . . . . .	15
3.3	Models Used . . . . .	17
3.3.1	Deep Neural Network (DNN) . . . . .	17
3.3.2	Decision Tree . . . . .	19
3.3.3	Multi-lead Diagnostic Attention-Based Recurrent Neural Network (MLDA-RNN) . . . . .	20
3.4	Detailed Proposed Workflow . . . . .	22
3.4.1	Stage 1: Data Acquisition . . . . .	22
3.4.2	Stage 2: Preprocessing and Normalization . . . . .	23
3.4.3	Stage 3: Integer Haar Wavelet Transform . . . . .	23
3.4.4	Stage 4: Recurrent Neural Encoding . . . . .	23
3.4.5	Stage 5: Attention and Classification . . . . .	24
3.5	Evaluation Metrics . . . . .	24
3.6	Implementation Considerations . . . . .	25
<b>4</b>	<b>Experiments and Results</b>	<b>27</b>
4.1	Machine Learning Models . . . . .	27
4.2	Result Interpretation . . . . .	36
4.3	Comparison with Baseline Models . . . . .	36
4.4	Clinical Relevance of the Results . . . . .	37
4.5	Error Analysis . . . . .	38
4.6	Limitations of the Present Work . . . . .	38
4.7	Practical Deployment Considerations . . . . .	39
<b>5</b>	<b>Conclusion and Future Work</b>	<b>40</b>
5.1	Conclusion . . . . .	40
5.2	Future Work . . . . .	40

## LIST OF FIGURES

1.1	Normal heart vs Heart failure . . . . .	1
1.2	ECG Signal . . . . .	2
3.1	Mallat's Algorithm [1] . . . . .	14
3.2	Deep Neural Network . . . . .	18
3.3	Deep Neural Network Architecture . . . . .	19
3.4	RNN Encoding block [2] . . . . .	21
3.5	GRU Cell [2] . . . . .	22
4.1	ROC Curve of ARNN Model . . . . .	29
4.2	Confusion matrix of ARNN Model . . . . .	29
4.3	Confusion matrix of DT by taking CA . . . . .	30
4.4	ROC curve of decision tree by taking CA . . . . .	30
4.5	Confusion matrix of DNN by taking CA . . . . .	31
4.6	ROC curve of DNN by taking CA . . . . .	31
4.7	ROC curve of DNN by taking CD . . . . .	32
4.8	Confusion matrix of DNN by taking CD . . . . .	32
4.9	ROC curve of Decision tree by taking CD . . . . .	33
4.10	Confusion matrix of DT by taking CD . . . . .	33
4.11	ROC curve of DNN by taking CA and CD . . . . .	34
4.12	Confusion matrix of DNN by taking CA and CD . . . . .	34

## LIST OF TABLES

1.1	Major challenges in ECG-based CHF detection . . . . .	5
2.1	Previous Works of Congestive Heart Failure Detection . . . . .	9
2.2	Difference between random split and patient-wise split . . . . .	11
3.1	Summary of the proposed CHF detection workflow . . . . .	24
3.2	Evaluation metrics used for CHF classification . . . . .	25
4.1	Metrics result of different models by using CD of HIT . . . . .	27
4.2	Metrics result of different models by using CA of HIT . . . . .	27
4.3	Metrics result of different models by combining CA and CD of HIT together . . . . .	28
4.4	Comparison of proposed work with state of the art method . . . . .	35
4.5	Qualitative comparison of models used in this work . . . . .	37

# CHAPTER 1

## INTRODUCTION

### 1.1 Background

#### 1.1.1 Congestive Heart Failure

Congestive heart failure (CHF) is a chronic cardiac condition in which the pumping function of the heart becomes inadequate for the body's circulatory demand. Global estimates for 2017 report approximately 64.34 million CHF cases [3], which makes the disease a major public-health concern. Clinical presentation is not uniform: patients may show reduced, preserved, or mid-range ejection fraction, and symptoms can overlap with other cardiopulmonary disorders. Therefore, diagnosis usually depends on a combination of clinical history, examination, imaging, laboratory findings, and electrical measurements. ECG-based analysis is attractive in this setting because ECG is inexpensive, non-invasive, widely available, and repeatable. This project therefore treats ECG as a practical input signal for CHF screening rather than as a standalone replacement for full clinical diagnosis.

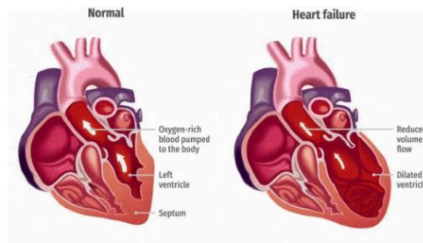


Figure 1.1. Normal heart vs Heart failure

### 1.1.2 Electrocardiogram Signals (ECG Signals)

An electrocardiogram records the electrical activity produced during each cardiac cycle. It is painless, quick to acquire, and widely used for examining rhythm, conduction, and changes in cardiac morphology. The atria and ventricles depolarize and repolarize in a coordinated sequence, producing the visible ECG waveform. As illustrated in Fig. 1.2, the main waveform components are the P wave, QRS complex, and T wave. The P wave reflects atrial depolarization, the QRS complex is associated with ventricular depolarization, and the T wave represents ventricular repolarization. Because ventricular muscle mass is larger than atrial muscle mass, the QRS complex normally appears with greater amplitude. Changes in intervals, amplitude, and morphology can therefore provide useful diagnostic information.

ECG acquisition is available through hospital equipment and, increasingly, through portable or wearable devices. In clinical practice, ECG may be recorded when symptoms such as chest discomfort, dizziness, rapid pulse, shortness of breath, weakness, fatigue, or reduced exercise capacity are reported. For CHF-related analysis, the value of ECG lies in its ability to capture rhythm and morphology changes repeatedly over time, making it suitable for computational screening and follow-up support.

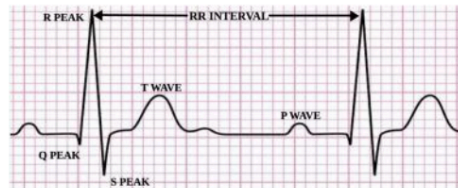


Figure 1.2. ECG Signal

## 1.2 Clinical and Technical Background

The diagnosis of congestive heart failure is not based on a single observation; rather, it is generally supported by a combination of symptoms, physical examination, imaging findings, laboratory investigations, and electrical activity recorded through ECG. Common clinical symptoms include shortness of breath, fatigue, swelling of the lower

limbs, and reduced exercise tolerance. However, these symptoms can overlap with other respiratory or metabolic conditions. For this reason, automated ECG-based analysis can act as a useful complementary screening tool, especially when continuous or repeated monitoring is required.

CHF can have several effects on the ECG from a signal processing standpoint. The disease may change the timing, shape and variability of the cardiac cycles. Features such as QRS duration, RR interval variability, ST-T segment behaviour and beat-to-beat rhythm regularity can reflect changes in ventricular activation, autonomic regulation and myocardial conduction. A cardiologist can visually inspect the ECG traces, but subtle temporal changes over long recordings are difficult to assess manually. Therefore automated systems are useful as they can consistently process many ECG segments and extract hidden patterns that may not be obvious in a short visual inspection. Multi-lead ECG recordings are of special importance, since each lead looks at the heart from a different electrical point of view. One lead may be able to record rhythm information but not be able to pick up spatial abnormalities that can be seen in another lead. Combining multiple leads enables the model to learn the complementary representations of cardiac activity. In this project, the study of multi-lead ECG allows the model to learn both the temporal dependence of each lead and the diagnostic dependence between leads. This is one of the reasons why recurrent neural networks with attention mechanisms are suitable for the task. Calculation efficiency is of practical importance for the CHF detection system. ECG monitoring is gradually shifting to portable devices, bedside monitors and wearable healthcare systems. These platforms can have limited memory, battery capacity, and processing power. Thus, feature extraction techniques, such as the Integer Haar Wavelet Transform, are useful, as they can provide useful time-frequency information without the heavy computational cost of more complex transforms. This project exploits this idea to support a model design that is not just accurate but also relevant for low resource deployment.

### **1.2.1 Need for Automated CHF Detection**

The increasing burden of cardiovascular disease and the need for early warning systems motivate automated CHF detection. Many patients seek medical attention only after symptoms become serious, so an ECG-based screening system can help identify abnormal patterns earlier and guide further examination. Such a system does not replace the physician; instead, it can prioritise cases, reduce manual workload, and provide objective measurements during repeated monitoring.

The main advantages of ECG-based automated CHF detection are, as follows: •  
Non-invasive measurement: ECG recording does not require surgical intervention and

is accepted in clinical practice. • Cost-Effective: ECG devices are generally cheaper than advanced imaging techniques like MRI or nuclear imaging. • Continuous monitoring: ECG signals can be recorded for extended periods of time, making them suitable for remote and wearable monitoring. • Objective analysis: Machine learning models can process large amounts of ECG data reliably. • Early detection: Automated systems can detect suspicious patterns and assist clinicians in making timely decisions. With these advantages, building a robust automated system is a challenge. ECG signals are noisy, patient dependent and affected by electrode placement, movement, baseline drift and physiological variations. Further, a model trained on randomly partitioned ECG segments may perform well on testing but not on unseen patients. This project overcomes this limitation by using patient-wise separation, which is more stringent and closer to real-world deployment.

### **1.2.2 Challenges in ECG Based Classification**

There are some challenges to be addressed but ECG signals can be effectively used for CHF classification. First, ECG signals are often contaminated by artifacts due to muscle activity, power-line interference, and electrode motion. If not controlled, the model may learn irrelevant patterns due to such noise. Second, the ECG recordings of different patients may have different amplitude, heart rate and morphological features. If the model is not trained carefully these variations can degrade generalization. Third, CHF-associated changes might be subtle and occur over time rather than a single, obvious abnormality. Yet another big problem is data leakage. If there are beats or segments from the same patient in both train and test sets, the model may learn patient-specific patterns instead of disease-specific patterns. This can lead to overly optimistic results. Therefore, patient-wise data splitting is important for evaluating how the model behaves on truly unseen subjects. In the present work, blind test data are created to reduce this risk and to provide a more meaningful estimate of performance.

**Table 1.1.** Major challenges in ECG-based CHF detection

<b>Challenge</b>	<b>Cause</b>	<b>Effect on model</b>
Noise and artifacts	Electrode movement, muscle activity, power-line interference	Distorts ECG morphology and may reduce classification accuracy
Patient variability	Differences in age, heart rate, disease severity, and physiology	Makes generalization to unseen patients difficult
Lead variation	Different leads capture different electrical views of the heart	Important diagnostic information may be missed by single-lead models
Temporal dependency	CHF patterns may appear across multiple beats	Static features may fail to capture long-term signal behaviour
Data leakage	Random segment-level splitting of ECG data	Inflates testing performance and reduces real-world reliability

### 1.3 Research Motivation

The motivation of this work is to examine whether multi-lead ECG signals can be used to separate CHF and normal sinus rhythm subjects under a patient-wise evaluation protocol. A patient-wise split is important because segment-level random splitting can place signals from the same subject in both training and testing sets, which may overestimate generalization. The study therefore compares baseline machine learning models with an attention-based recurrent model and uses the blind test result as the main evidence of performance.

The novelty of our work is to come up with a multi-lead diagnostic attention-based recurrent neural network for the classification of CHF. The method analyses the two-lead ECGs to extract the multi-scale temporal dependencies from each lead for better classification.

#### **1.4 Organization Of The Report**

The remaining chapters are arranged to present the study in a logical sequence. Chapter 2 reviews earlier ECG-based CHF detection studies and introduces the datasets used in this dissertation. Chapter 3 explains the signal-processing method, the feature-generation procedure, and the classification models. Chapter 4 presents the experiments, compares the obtained results, and discusses the behaviour of the models. Chapter 5 summarizes the major findings and outlines possible extensions of the work.

## CHAPTER 2

### REVIEW OF PRIOR WORKS

#### 2.1 Literature Review

Recent studies on CHF detection from ECG abandoned the traditional hand-crafted heart-rate-variability analysis in favor of modern deep learning models that directly operate on ECG sequences. CHF is a major cardiovascular disease because of its large population of patients and the risk of rehospitalization and sudden deterioration if not identified early. Many researchers have explored the potential of using ECG-derived patterns to discriminate CHF subjects from normal subjects and other cardiac conditions due to its low cost, non-invasive nature, and availability for ECG recording. Early studies were mainly based on manually designed descriptors. Melillo et al. [4] reported high sensitivity with comparatively lower specificity using long-term HRV measurements and a classification and regression tree. Orhan [5] classified CHF and normal sinus rhythm patterns using amplitude and time partitioning features. Masetic and Subasi [6] used autoregressive Burg features with a decision tree classifier and obtained high classification accuracy. These approaches show that ECG and HRV data contain useful diagnostic information, but their performance depends strongly on the selected features. Machine learning methods such as KNN, LDA, MLP, SVM, and RBF-based neural networks have also been explored for CHF identification. Isler and Kuntalp [7] focused on short-term and long-term HRV information and achieved good results using classical classifiers. Fuadah and Lim [8] employed Hjorth descriptors and entropy-based features with different classifiers on the MIT-BIH and BIDMC records. Their results show that well-designed features can support accurate CHF detection, but feature engineering may require domain knowledge and may not generalize equally well across datasets.

With the growth of deep learning, researchers began to reduce dependence on manually selected features. Acharya et al. [9] applied a convolutional neural network directly to raw ECG data, showing that deep models can learn discriminative representations automatically. Darmawahyuni et al. [10] used an LSTM-based model for sequential ECG analysis, while Prabhakararao and Dandapat [11] used a multilayer

recurrent neural network that accepts ECG signals as input. These studies demonstrate the suitability of recurrent and convolutional architectures for ECG classification tasks.

Wavelet-based methods remain relevant because ECG signals are non-stationary. Nahak et al. [12] compared HRV features and wavelet-based features for a three-class classification problem involving arrhythmia, CHF, and normal sinus rhythm. They observed that wavelet information contributed strongly to classification performance. Zou et al. [13] proposed a multiscale residual UNet++ approach, highlighting the importance of multiresolution analysis and hardware-oriented design considerations. Similarly, the MLDA-RNN method proposed by Prabhakararao and Dandapat [2] uses multi-lead ECG information with an attention-based recurrent structure, which is closely related to the direction followed in this project.

Recent studies have extended ECG classification using transformer-based and hybrid architectures. Liu et al. [14] proposed ECVT-Net, which combines convolutional processing with a vision transformer for extracting high-level ECG features. Prusty et al. [15] converted ECG information into a form suitable for a 2D CNN using scale-invariant feature transform ideas. Mahmoud et al. [16] used a CNN-LSTM framework with frequency-domain preprocessing, and Odinaka et al. [17] investigated transfer learning using pretrained image models. More recently, Lee et al. [18] demonstrated the potential of deep learning on standard 12-lead ECG recordings for heart-failure-related diagnosis in clinical settings.

Overall, the literature suggests three important observations. First, ECG signals contain measurable information related to CHF. Second, deep learning models can reduce manual feature-design effort and can capture nonlinear temporal relationships. Third, evaluation strategy is critical: random segment-level splitting may overestimate performance if patient identity information leaks into the testing set. Motivated by these points, the present work uses patient-wise data separation and evaluates an MLDA-RNN-based approach using multi-lead ECG signals.

## 2.2 Datasets Used

### 2.2.1 MIT-BIH Normal Sinus Rhythm Database

This database contains long-term ECG recordings of 18 patients which includes 5 males and 13 women from Boston’s Beth Israel Hospital’s Arrhythmia Laboratory. Their patients were found to have no symptoms of arrhythmias. Each recording contains 2 ECG leads and is sampled at 128 samples per second.

**Table 2.1.** Previous Works of Congestive Heart Failure Detection

Work	Year	Features	Extraction Method / Technique used	Database Used	Accuracy	Model Used
[11]	2022	ECG signal	—	MIT-BIH, BIDMC, PTBDB	98.57%	multilayered RNN
[10]	2020	—	—	MIT-BIH, BIDMC	99.86%	LSTM
[8]	2022	Hjorth Descriptor and Entropy	—	MIT-BIH, BIDMC	RBFN: 97%, re-remaining 100%	RBFN, SVM, kNN, RF, and ANN
[9]	2019	—	—	NSRDB, Fantasia, BIDMC	98.97%	CNN
[2]	2020	Direct ECG lead	—	STAFF III and PTB diagnostic	97.79%	MLDA-RNN
[13]	2022	HRV features	—	NSRRR and CHF-RR interval database	89.83%	Multiscale Residual UNet++
[12]	2020	HRV features, wavelet based features	—	MIT-BIH Arrhythmia, BIDMC and MIT-BIH NSRD	fusion of HRV and wavelet based features produced 93.33% accuracy	SVM
[14]	2022	ECG signal	CNN + Vision Transformer	MIT-BIH, BIDMC	98.88%	ECVT-Net
[17]	2023	ECG signal (time-frequency)	Transfer learning	MIT-BIH, BIDMC	99.2%	ResNet-50, AlexNet
[15]	2024	SIFT image features	Scale-Invariant Feature Transform	PhysioNet (ARR, CHF, NSR)	99.78%	2D-Deep CNN
[16]	2024	FFT + raw ECG	FFT preprocessing	MIT-BIH, BIDMC	—	CNN-LSTM
[18]	2025	12-lead ECG waveforms	Deep learning (end-to-end)	Samsung Medical Center cohort	—	Deep learning (AI-ECG)

### 2.2.2 BIDMC Congestive Heart Failure Database

This database contains long-term ECG recordings from 15 patients with severe congestive heart failure, including 11 men and 4 women, ages 22 to 71 (NYHA class 3–4). Each recording consists of 20 hours in duration and contains 2 ECG leads, sampled at 250 samples per second.

## 2.3 Dataset Preparation and Study Design

The reliability of any machine learning model depends strongly on how the dataset is prepared. In biomedical signal classification, dataset preparation is especially important because the model may otherwise learn artifacts, recording conditions, or patient identities instead of the disease pattern. For this reason, the proposed work follows a structured preparation strategy consisting of signal selection, patient-wise grouping, preprocessing, segmentation, feature extraction, and model evaluation.

The MIT-BIH Normal Sinus Rhythm Database contains normal subjects and the BIDMC Congestive Heart Failure Database contains CHF subjects. These two datasets provide ECG recordings from different physiological groups and are therefore suitable for binary classification of CHF versus normal sinus rhythm. The classification task is to determine whether a given ECG segment is of the CHF class or of the normal class. Since ECG signals are time series, the model must learn not only isolated values but also temporal patterns that change over multiple samples and beat

### 2.3.1 Patient-wise Data Separation

We made a conscious decision to separate patients in this design. Many ECG classification studies divide long recordings into several short segments and then separate them into training and testing sets randomly. This generates many samples, but also means that segments from the same patient could end up in both sets. In such a case, the test set is not truly independent, because the model has already seen the signal characteristics of the same patient during training. This can lead to the reported accuracy being inflated relative to the true real-world performance.

To avoid this issue, the present work separates the data at the patient level. All ECG segments belonging to a particular patient are placed either in the training set or in the testing set, but not both. This produces blind test data and gives a better estimate of how the model will behave when it receives ECG data from a new patient. The method is more challenging because the model must learn general CHF-related characteristics instead of memorizing individual patient patterns.

**Table 2.2.** Difference between random split and patient-wise split

Criterion	Random segment split	Patient-wise split
Data division	ECG segments are randomly divided	Complete patient recordings are separated
Risk of leakage	High, because same patient may appear in train and test sets	Low, because test patients are unseen
Reported accuracy	May be overly optimistic	More realistic and difficult
Clinical relevance	Limited for unseen-patient deployment	Better suited for real screening systems
Model requirement	Can exploit patient-specific patterns	Must learn disease-specific patterns

### 2.3.2 Signal Preprocessing

Raw ECG signals are not directly useful for classification as they may contain noise and baseline fluctuations. Preprocessing enhances the signal quality and directs the model toward diagnostically relevant information. The main preprocessing steps considered in this work are baseline correction, normalization, segmentation and quality checking. Baseline correction can reduce slow drift caused by respiration or electrode movement. Normalization reduces the amplitude differences across recordings, so the model is less biased towards signal magnitude. Segmentation divides long ECG recordings into smaller windows to be processed by the neural network. Quality checking is also important because poor-quality ECG segments may contain artifacts that are not representative of cardiac activity. If the model is trained on these segments, it may learn spurious patterns. In a practical system, noisy segments should be removed or handled separately by a signal quality assessment module. The quality-aware block in the proposed framework supports this requirement by ensuring that only usable ECG segments are propagated for classification.

### 2.3.3 Segmentation Strategy

The neural networks usually take fixed-size input windows, while ECG recordings are continuous signals. Hence, segmentation is performed to convert each recording into smaller windows. The length of the segment must be chosen carefully. Too short segment may not contain enough cardiac cycles to represent temporal behaviour. If it is too long, the computational cost increases and the number of training samples

decreases. A balanced segment length is one where the model can see multiple beats and keep computation manageable. Segment level classification is useful for detection of CHF, because it allows to analyse long patient recordings in smaller parts. Finally, a patient-level decision can be made by aggregating segment predictions by majority voting or averaging of probabilities. Although the focus of this project is on segment-level classification, the framework can be generalized to patient-level screening by aggregating predictions over time.

#### <sup>32</sup> **2.3.4 Feature Representation**

Feature representation is a crucial part of the suggested methodology. ECG signals contain information in time and frequency domains. In the time domain, wave shape, beat interval, and amplitude variation are patterns; in the frequency domain, rhythm irregularities and signal energy distribution are patterns. Wavelet-based methods are well suited for ECG analysis due to the non-stationary nature of ECG and its time-varying frequency content. The Integer Haar Wavelet Transform gives a simple and efficient representation of the signal at different resolutions.

In addition to wavelet-based features, the recurrent neural network learns temporal representations directly from the ECG sequence. The attention mechanism further helps the model assign greater importance to diagnostically meaningful parts of the signal. Thus, the proposed method combines handcrafted signal processing principles with trainable deep learning representations.

## CHAPTER 3

### ALGORITHMS AND MODELS USED FOR DETECTION OF CHF

For efficient hardware implementation of algorithms, the feature extraction module is supposed to be computationally inexpensive which means utilizing minimum memory. So our work consists of a computationally efficient algorithm that is memory and power-efficient. The algorithm is appropriate for low-power wearable devices with limited resources.

#### 3.1 Wavelet Transform

ECG is a non-stationary biomedical signal, which means that its frequency content changes with time. A method that only describes the signal in the time domain may miss frequency-related information, while a method that only describes the frequency domain may ignore when a particular event occurs. Wavelet transform is useful for such signals because it provides a time-frequency representation. It decomposes the signal into components that describe both slow variations and rapid changes.

In ECG analysis, wavelet decomposition is useful because different parts of the ECG waveform have different frequency characteristics. The QRS complex is sharp and usually contains higher-frequency information, whereas baseline trends and rhythm-related variations are represented more strongly in lower-frequency components. By separating approximation and detail coefficients, wavelet processing can provide a compact representation for classification.

A general wavelet-based feature extraction system applies low-pass and high-pass filtering followed by downsampling. The low-pass branch produces approximation coefficients, while the high-pass branch produces detail coefficients. Repeating this process over multiple levels gives a multiresolution view of the ECG signal. This project uses this idea through the Integer Haar Transform so that feature extraction remains computationally simple.

### 3.1.1 Mallat's Algorithm

Mallat's algorithm is a fast implementation of the discrete wavelet transform. The input signal at each level is filtered by a low pass filter and a high pass filter.

Then the outputs of these filters are downsampled by a factor of 2. The low pass output gives the approximation part of the signal. The high pass output gives the detail part. Again we can decompose the approximation output to get the next level of coefficients.

This repeated filtering and downsampling structure makes the algorithm efficient and applicable to multilevel analysis; In ECG processing, the lower level detail coefficients may retain sharp transitions, while the deeper approximation coefficients retain slower signal trends. The number of decomposition levels is chosen based on the sampling rate, length of segment and the type of features required by the classifier.

There exist several wavelet families for signal analysis such as Haar, Daubechies, Symlets and Coiflets. The choice of the wavelet impacts the compactness and interpretability of the extracted features. In this project, Haar-based processing is chosen because of its simple structure and its suitability for low-complexity implementation

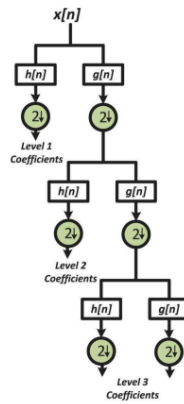


Figure 3.1. Mallat's Algorithm [1]

### 3.1.2 Integer Haar Transform (IHT)

The Haar wavelet is the simplest wavelet basis and is often used when computational efficiency is important. The low-pass and high-pass filter coefficients can be expressed as follows [1]:

$$g = \frac{1}{\sqrt{2}}[1, 1] \quad (3.1)$$

$$h = \left[ \frac{1}{\sqrt{2}}, -\frac{1}{\sqrt{2}} \right] \quad (3.2)$$

The standard Haar transform uses floating-point operations because of the scaling factor. Floating-point arithmetic may increase area, energy use, and implementation complexity for low-power hardware. Integer Haar Transform addresses this difficulty by using integer operations and shift-based computation, making it attractive for wearable ECG systems with limited memory and power resources.

The approximation coefficient (CA) and detail coefficient (CD) used in this work are represented as [1]:

$$C_A[n] = \left\lfloor \frac{1}{2} \left( x[2n] + \frac{1}{2}x[2n+1] \right) \right\rfloor \quad (3.3)$$

$$C_D[n] = x[2n] - x[2n+1] \quad (3.4)$$

Division by powers of two can be implemented using right-shift operations in digital hardware. Therefore, IHT is suitable for extracting ECG features in systems where the classifier may be deployed on a resource-constrained device.

### 3.2 Methodology Used

The objective of the methodology is to classify ECG records into CHF and normal categories using a structured signal-processing and machine-learning pipeline. Three types of models are considered: a decision tree, a deep neural network, and the multi-lead diagnostic attention-based recurrent neural network (MLDA-RNN). The decision tree and DNN are used as baseline models, while MLDA-RNN is treated as the main model because it is better suited for sequential multi-lead ECG data.

The data are divided at the patient level into training, validation, and testing subsets. This design is intentionally used to reduce data leakage. For the BIDMC CHF database, 10 patients are used for training, 2 patients are used for validation, and 3 patients are kept for testing. For the MIT-BIH Normal Sinus Rhythm database, 12 patients are used for training, 3 patients for validation, and 3 patients for testing. Since complete patients are assigned to only one subset, the final testing set behaves as blind data.

The BIDMC recordings represent the CHF class. For each patient, ECG signals are read, filtered, and stored in an array for further processing. The filtered signal is then divided into fixed-length windows of 750 samples. Each window is arranged as one row in the feature-generation pipeline. For the BIDMC training subset, this produces an array of size  $238885 \times 750$ . Integer Haar Transform is then applied repeatedly to obtain approximation coefficients (CA) and detail coefficients (CD). After six iterations of the transform, the CA and CD feature matrices for BIDMC training have dimensions  $238885 \times 12$  each.

The same procedure is followed for validation and testing records of the BIDMC database. The validation feature matrices for CA and CD have dimensions  $47782 \times 12$  and  $47787 \times 12$ , respectively. The testing feature matrices for both CA and CD have dimensions  $71984 \times 12$ . These values show that the pipeline converts long ECG recordings into compact wavelet-based representations while maintaining patient-wise separation.

The MIT-BIH Normal Sinus Rhythm database is processed in a similar manner. Since the BIDMC recordings are sampled at 250 Hz and the MIT-BIH recordings are sampled at 128 Hz, MIT-BIH signals are first resampled to 250 Hz to maintain consistency between the two classes. After resampling, ECG filtering is performed, and the resulting signal is segmented into windows of 750 samples. For the MIT-BIH training subset, the segmented array has size  $181325 \times 750$ .

Integer Haar Transform is then applied to the MIT-BIH segments. The CA and CD matrices for the training subset both have size  $181325 \times 12$ . For validation, both CA and CD matrices have size  $44068 \times 12$ . For testing, both feature matrices have size  $43395 \times 12$ . These transformed features are used to construct input sets for the machine learning and deep learning models.

Three feature configurations are evaluated so that the contribution of wavelet components can be compared. In the first configuration, CA and CD are concatenated and used together. In the second configuration, only CA features are used. In the third configuration, only CD features are used. This comparison is useful because CA represents lower-frequency approximation information, whereas CD represents detail information. The results show how each representation affects model behaviour.

1. Combined CA and CD features are used for training, validation, and testing.
2. Only approximation coefficient features (CA) are used.
3. Only detail coefficient features (CD) are used.

The same training and testing protocol is applied to all selected models. This ensures that the comparison among the decision tree, DNN, and MLDA-RNN is based on the same data division and feature configurations. The final analysis is then performed using accuracy, sensitivity, specificity, confusion matrices, and ROC curves.

### 3.3 Models Used

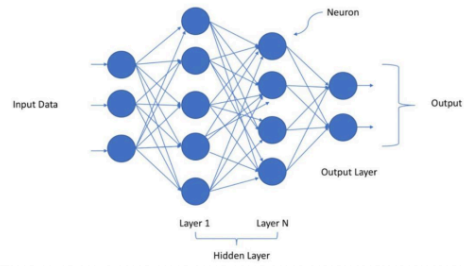
#### 3.3.1 Deep Neural Network (DNN)

A deep neural network is a multilayer computational model that learns a mapping between input features and output classes. In this project, the DNN is used as a baseline deep learning classifier for wavelet-derived ECG features. Unlike a decision tree, which splits data using explicit threshold rules, a DNN learns nonlinear combinations of features through trainable weights and activation functions.

The main components of a DNN are described below:

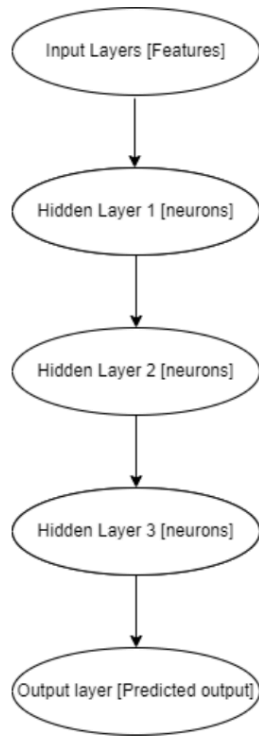
1. **Input layer:** The input layer receives the feature vector generated from ECG segments. Depending on the experiment, this vector may contain CA features, CD features, or a combination of both.
2. **Hidden layers:** Hidden layers transform the input into progressively more useful internal representations. Each neuron computes a weighted sum of its inputs and passes it through an activation function. In this work, hidden dense layers are used to learn relationships among ECG features.
3. **Activation function:** Activation functions introduce nonlinearity into the network. Without them, the entire network would behave like a linear model. ReLU is used in hidden layers because it is simple and effective for deep learning models.
4. **Output layer:** The output layer produces the final class probability. Since the task is binary classification, a sigmoid activation is suitable for predicting whether a segment belongs to the CHF or normal class.
5. **Loss function:** Binary cross-entropy is used to compare predicted probabilities with true labels. The training process minimizes this loss.
6. **Optimization:** The Adam optimizer updates the network parameters during training. It adapts the learning rate for different parameters and is widely used for neural network training.

7. **Regularization:** Regularization methods such as dropout or weight penalties can reduce overfitting. This is important because biomedical datasets may contain limited patient-level diversity.



**Figure 3.2.** Deep Neural Network

Deep neural architecture with three hidden layers is shown below:



**Figure 3.3.** Deep Neural Network Architecture

In this project, the DNN input size depends on the number of selected features. The model uses dense hidden layers with 64 and 32 neurons, respectively. ReLU is used in the hidden layers, and sigmoid activation is used in the output layer. The model is trained using Adam optimization, binary cross-entropy loss, 10 epochs, and a batch size of 32. The DNN helps evaluate how well non-sequential deep learning performs on the extracted ECG features.

### 3.3.2 Decision Tree

A decision tree is a supervised learning model that predicts the output class by applying a sequence of feature-based decisions. Each internal node of the tree checks a condition

on a feature, each branch corresponds to the outcome of that condition, and each leaf node represents a predicted class. Decision trees are easy to interpret because the path from root to leaf can be examined as a set of rules.

For ECG classification, a decision tree can be used to test whether wavelet-derived features contain enough discriminative information for separating CHF and normal signals. The model is computationally light and does not require complex training. However, its rule-based structure may not capture subtle temporal relationships in ECG signals. It may also overfit if the tree grows too deep.

In this work, the decision tree classifier is implemented using the `DecisionTreeClassifier` class from the scikit-learn library. The input to the classifier is generated from the same Integer Haar Transform pipeline used for the other models. This allows a fair comparison between a classical machine learning baseline and neural network-based models.

### 3.3.3 Multi-lead Diagnostic Attention-Based Recurrent Neural Network (MLDA-RNN) [2]

The MLDA-RNN model is selected because ECG data are sequential and multi-lead in nature. A recurrent network is more appropriate than a purely dense model when the order of samples carries diagnostic meaning. The model can process a sequence of ECG values and maintain hidden states that summarize previously observed information. This helps in learning rhythm-related and morphology-related changes across time.

A multi-lead design is useful because each ECG lead records cardiac electrical activity from a different viewpoint. Some leads may contain stronger evidence of CHF-related abnormalities than others. Therefore, the model should not treat all lead information as equally informative in every case. The attention mechanism addresses this by assigning greater importance to more useful parts of the learned representation.

The proposed architecture contains the following conceptual blocks:

**Input Block.** The input block receives preprocessed ECG segments. Depending on the experiment, the input may contain approximation coefficients, detail coefficients, or their combination. The purpose of this block is to arrange the ECG-derived features in a form that can be processed by the recurrent network.

**Quality Aware Block.** Quality Aware Block. ECG recordings can have noise, baseline drift, or artifacts. A quality awareness stage helps to provide useful ECG segments to the model. The probability that the classifier learns non-cardiac noise patterns is re-

duced.

**Recurrent Neural Network Encoding Block.** Recurrent Neural Network Encoder Unit The recurrent encoding block learns the temporal dependencies in the sequence of ECG. However, basic RNN units can learn sequential data, but they often struggle with vanishing or exploding gradients when long dependencies are involved. Gated recurrent units (GRUs) solve this problem by gating mechanisms, but with fewer parameters than LSTM units. Thus, GRU is a good choice for ECG datasets with importance on computational simplicity and generalization.

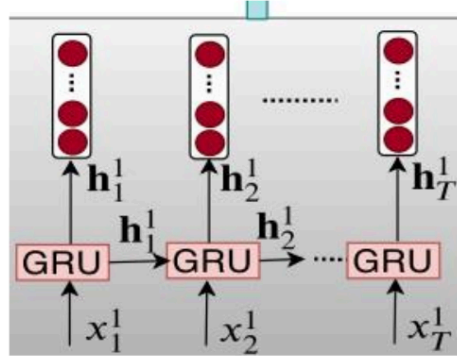


Figure 3.4. RNN Encoding block [2]

Let the ECG sequence for lead  $m$  be denoted as  $\mathbf{x}^m = [x_1^m, x_2^m, \dots, x_T^m]$ . Here,  $x_t^m$  represents the value or feature at time step  $t$  for lead  $m$ . The GRU uses an update gate and a reset gate to decide how much past information should be retained and how much new information should be added.

The hidden state is updated as follows [2]:

$$\mathbf{h}_t^m = (1 - \mathbf{z}_t^m) \odot \mathbf{h}_{t-1}^m + \mathbf{z}_t^m \odot \tilde{\mathbf{h}}_t^m \quad (3.5)$$

$$\mathbf{z}_t^m = \sigma(\mathbf{W}_{z_i}^m x_t^m + \mathbf{W}_{z_h}^m \mathbf{h}_{t-1}^m + \mathbf{b}_z^m) \quad (3.6)$$

In these expressions,  $\sigma(\cdot)$  is the sigmoid function,  $\mathbf{z}_t^m$  is the update gate,  $\mathbf{h}_{t-1}^m$  is the previous hidden state, and  $\tilde{\mathbf{h}}_t^m$  is the candidate hidden state. The candidate hidden state is computed as:

$$\tilde{\mathbf{h}}_t^m = \tanh(\mathbf{W}_{cr}^m x_t^m + \mathbf{W}_{cr}^m (\mathbf{r}_t^m \odot \mathbf{h}_{t-1}^m) + \mathbf{b}_c^m) \quad (3.7)$$

Here,  $\mathbf{r}_t^m$  is the reset gate,  $\odot$  indicates element-wise multiplication, and the  $\mathbf{W}$  and  $\mathbf{b}$  terms represent trainable weights and biases. These equations allow the GRU to control the flow of historical and current information through the sequence.

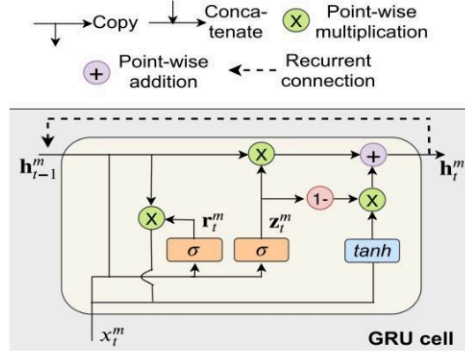


Figure 3.5. GRU Cell [2]

After recurrent encoding, the attention mechanism assigns weights to learned features so that the model can emphasize diagnostically important information. The final classification layer then predicts whether the ECG segment belongs to the CHF class or the normal sinus rhythm class.

### 3.4 Detailed Proposed Workflow

The workflow proposed here aims to transform raw multi-lead ECG recordings into reliable CHF predictions. The whole process consists of five main stages, namely data acquisition, pre-processing, feature extraction, temporal modelling and classification. Every step adds to the ultimate performance of the system. Any weakness at any stage can affect the final output, therefore the workflow is designed as a structured pipeline rather than a single isolated classifier.

#### 3.4.1 Stage 1: Data Acquisition

In the first stage, the ECG records are taken from selected public databases. Normal class is represented by recordings from subjects with normal sinus rhythm, and

CHF class is represented by recordings from patients diagnosed with congestive heart failure. The signals need to be consistently processed before training as the different datasets may have different sampling frequencies and recording durations. In this step the recordings are grouped according to class labels and patients' identities.

#### **3.4.2 Stage 2: Preprocessing and Normalization**

The second step is to improve the quality of ECG signals. Biomedical signals are often contaminated by noise and baseline drift which will have negative impact on both feature extraction and neural network learning. Preprocessing removes these unwanted components. Once the noise reduction normalization is performed to put the signals on a common scale. This is important because the amplitude of ECG signals can vary due to electrode placement, patient body characteristics, and recording equipment. Normalization helps the model focus on relative changes in the waveform rather than the magnitude of the signal

#### **3.4.3 Stage 3: Integer Haar Wavelet Transform**

The third stage employs Integer Haar Wavelet Transform to obtain compact and informative features. The Haar transform decomposes a signal into approximation and detail components. The approximation coefficients capture the low frequency trend, while the detail coefficients capture the fast variations. Both of these components can be meaningful for ECG analysis. The approximation coefficients may relate to the overall rhythm. The detail coefficients may relate to the sharp QRS complexes and other abrupt transitions in the waveform. Integer implementation is good because it reduces computational complexity and avoids floating point heavy operations.

#### **3.4.4 Stage 4: Recurrent Neural Encoding**

The fourth stage employs a recurrent neural encoding block for learning temporal dependencies. ECG is a sequential signal. Interpretation of one sample or beat often depends on the previous and future patterns. We use GRU based recurrent units as they model temporal dependencies with less parameters than LSTM units. This is one reason why GRU is suitable for biomedical data sets where the amount of labelled data may be limited. The recurrent block produces hidden representations that summarize temporal information for each ECG lead.

### 3.4.5 Stage 5: Attention and Classification

The fifth stage uses attention and classification. The attention mechanism enables the model to attend more on more informative time steps or lead-specific features. In multi-lead ECG classification, not all leads are equally useful for all patients and segments. Some leads may show more marked abnormalities related to CHF than others. The attention mechanism helps the network to assign a larger weight to these useful features. The last layer is the classification layer which gives the probability of the segment of ECG to belong to the CHF class.

**Table 3.1.** Summary of the proposed CHF detection workflow

Stage	Purpose	Expected output
Data acquisition	Collect normal and CHF ECG recordings	Labelled patient-wise ECG dataset
Preprocessing	Remove noise and normalize amplitude	Clean ECG segments
Wavelet transform	Extract time-frequency information	Approximation and detail features
RNN encoding	Learn temporal dependencies	Hidden sequence representation
Attention and classification	Focus on informative patterns and classify	CHF or normal prediction

### 3.5 Evaluation Metrics

Accuracy is not sufficient to evaluate the performance of the model, especially in the medical classification. The classifier may be accurate if one class dominates the data set, but will not detect positive cases that are of clinical importance. Therefore, in this work we consider multiple evaluation metrics including accuracy, sensitivity, specificity, confusion matrix, receiver operating characteristic curve. The accuracy is the total number of correctly classified samples. Sensitivity (or true positive rate) is a measure of the ability of the model to correctly detect CHF cases. This is clinically significant as a missed CHF case may lead to a delay in treatment. Specificity is the ability of the model to correctly recognize normal cases. High specificity is also important, as too many false alarms may lead to loss of trust in the system and increase unnecessary clinical workload. So the confusion matrix gives a more detailed overview of right and wrong predictions. It is made up of true positives, true negatives, false pos-

itives and false negatives. The ROC curve shows the trade-off between the sensitivity and the false positive rate at different threshold values. A curve closer to the top-left corner would be a better model. Together, the metrics offer a more complete picture of the model than any single number.

**Table 3.2.** Evaluation metrics used for CHF classification

Metric	Formula/Meaning	Importance
Accuracy	Ratio of correct predictions to total predictions	Shows overall classification performance
Sensitivity	$TP/(TP + FN)$	Measures ability to detect CHF cases
Specificity	$TN/(TN + FP)$	Measures ability to identify normal subjects
False positive rate	$FP/(FP + TN)$	Indicates how often normal samples are misclassified
Confusion matrix	Counts TP, TN, FP, and FN	Gives detailed error distribution
ROC curve	Sensitivity versus false positive rate	Evaluates threshold-dependent behaviour

### 3.6 Implementation Considerations

The proposed model implementation requires careful selection of hyperparameters. The key parameters are segment length, batch size, number of recurrent units, number of dense neurons, learning rate, number of epochs, and dropout rate. If the model is too small, it can underfit and fail to learn useful patterns in the ECGs. If it is too large it may overfit and perform poorly on blind test patients. Thus, the architecture has to trade off learning capacity against generalization. Another important factor to consider is class imbalance. If one class has more segments than the other, the model can be biased towards the majority class. This problem might be dealt with by class balancing, careful sampling or class-weighting strategies. Also, training curves should be monitored to detect overfitting. If training accuracy goes up and validation accuracy goes down, the model is memorizing training data instead of learning general features. Inference speed is also important for real-time applications. Fast prediction and low power consumption are the requirements of a wearable or portable monitoring system. Efficient wavelet processing and a GRU-based recurrent model are used to cut down the computational load compared with heavier architectures. This makes the proposed

approach more convenient for practical health monitoring systems.

## CHAPTER 4

### EXPERIMENTS AND RESULTS

#### 4.1 Machine Learning Models

In the previous chapters, we have described the techniques and models in a detailed way. This chapter will contain the results of those experiments. At first, we will display the results of deep neural networks (DNN) and decision trees in three different ways.

1. By using only the detailed coefficient (CD) of Haar integer wavelet and generating the training and testing dataset.
2. By using only the approximate coefficient (CA) of the Haar integer wavelet and generating the training and testing dataset.
3. By combining detailed coefficient and approximate coefficient of Haar integer wavelet and generating the training and testing dataset.

**Table 4.1.** Metrics result of different models by using CD of HIT

Models	Accuracy	Sensitivity	Specificity	F1 score	AUC
Decision Tree	0.70025	0.6975	0.70225	0.6626405	0.69988
DNN	0.7884	0.739204	0.824289	0.746738	0.7817468

**Table 4.2.** Metrics result of different models by using CA of HIT

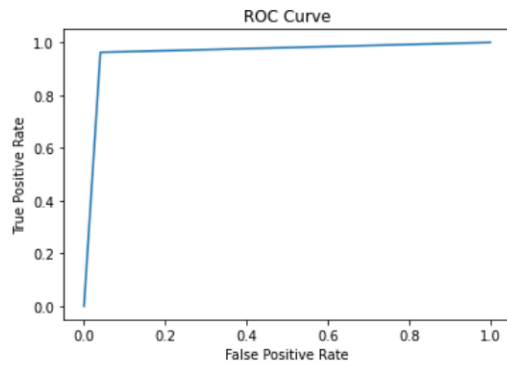
Models	Accuracy	Sensitivity	Specificity	F1 score	AUC
Decision Tree	0.8696787	0.76854	0.9435339	0.832717	0.856038
DNN	0.891	0.817214	0.94485309	0.863528	0.8810336

**Table 4.3.** Metrics result of different models by combining CA and CD of HIT together

<b>Models</b>	<b>Accuracy</b>	<b>Sensitivity</b>	<b>Specificity</b>	<b>F1 score</b>	<b>AUC</b>
Decision Tree	0.92538	0.8911311	0.950397	0.90975517	0.92076
DNN	0.9586	0.94729	0.9669	0.9508	0.95709
ARNN	0.960668	0.9622998	0.9596849	0.9484646	0.9609923

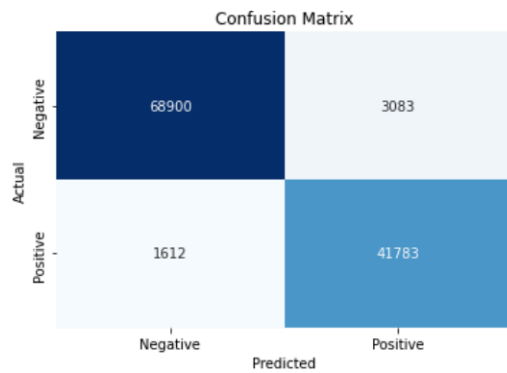
After observing the results of different models by three different methods – (1) by considering only CA, (2) by considering only CD, and (3) by combining both CA and CD – we can observe that all models DNN, Decision tree, and RNN give better results when CA and CD are combined. However, without combining CA and CD, models are giving better results with CA as compared to CD. So it is better to take both CA and CD into consideration; however, there is a problem with taking both CA and CD in that the algorithm will take more space and more time to compute the output. Compared to all three models we can see that ARNN outstands every other model by giving an accuracy of 96.066%.

The most important part of our results as compared to previous work carried out till now is that our results are produced on blind data. While dividing our datasets into training and testing parts we have not used any train-test split technique which divides our dataset randomly; instead, we have divided our dataset based on patients. So in this way, our model is completely unaware and is not friendly with our dataset. As per the literature survey we carried out, we can clearly state that the way we are dividing our dataset into training and testing has not been used till now, and the accuracy we have obtained with our ARNN model is remarkable on our blind dataset.



**Figure 4.1.** ROC Curve of ARNN Model

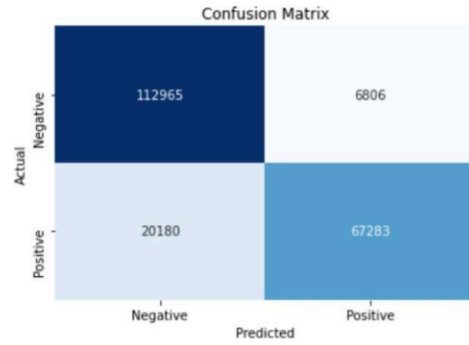
The above AUC-ROC figure is also called an Area Under the Receiver Operating Characteristics. ROC is a probability curve and AUC represents the degree or measure of separability for the model; it generally indicates how much our model is capable of separating different classes. It is plotted between the sensitivity and (1 – specificity). The higher the AUC, the better the model is capable of separating between different classes. The ROC curve of the ARNN model is approximately near to 1, which means that our model has a very good measure of separability and is very much capable of separating patients with the disease and without the disease.



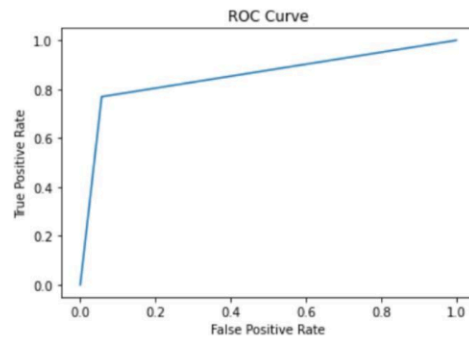
**Figure 4.2.** Confusion matrix of ARNN Model

A confusion matrix displays the counts of true positives, true negatives, false pos-

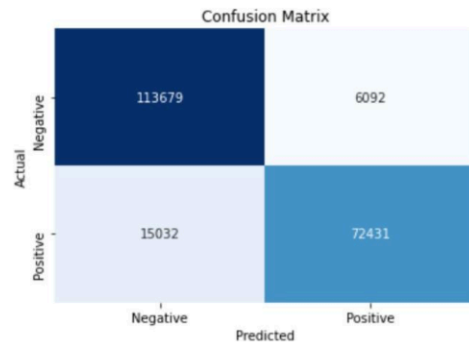
itives, and false negatives to summarise the performance of a classification model. In the above confusion matrix of the ARNN model, we can see that values of TN (true negative) and TP (true positive) are so high as compared to FN (False negative) and FP (False positive), hence our model is doing a very good classification.



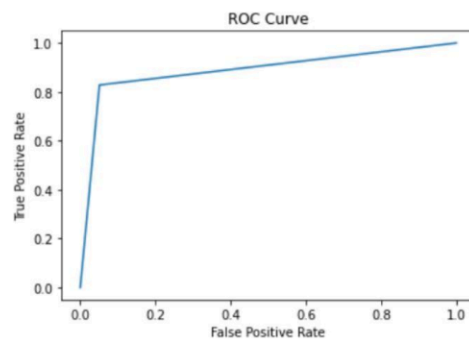
**Figure 4.3.** Confusion matrix of DT by taking CA



**Figure 4.4.** ROC curve of decision tree by taking CA

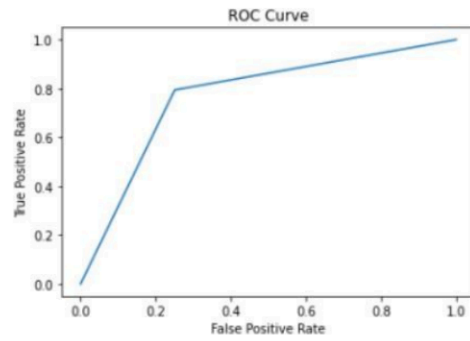


**Figure 4.5.** Confusion matrix of DNN by taking CA



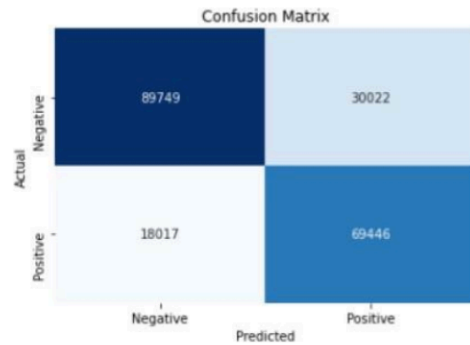
**Figure 4.6.** ROC curve of DNN by taking CA

Confusion matrix and ROC curve of DNN by taking CA are showing much better results as compared to confusion matrix and ROC curve of DT by taking CA. ARNN ROC curve and confusion matrix are showing better results as compared to ROC curve and confusion matrix of both DNN and DT.



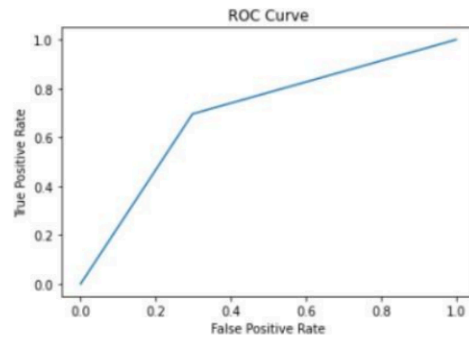
**Figure 4.7.** ROC curve of DNN by taking CD

From this figure, we can see that there is approximately 80% chance that our DNN model will be able to distinguish between positive class and negative class. Also, we can see that the ROC curve of DNN by considering CD is behaving poorly as compared to the ROC of DNN by taking CA.



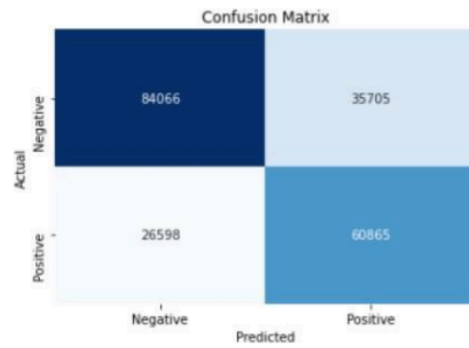
**Figure 4.8.** Confusion matrix of DNN by taking CD

We can see here that the DNN model by considering only CA was able to identify more TP and TN as compared to the DNN model by considering only CD.



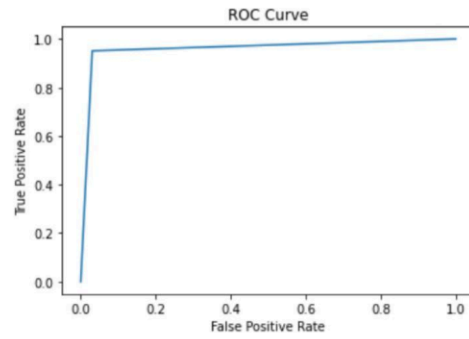
**Figure 4.9.** ROC curve of Decision tree by taking CD

The ROC curve of DT by CA is behaving well as compared to DT by CD. The ROC curve of ARNN is behaving well as compared to the ROC curve of DT by taking CD.



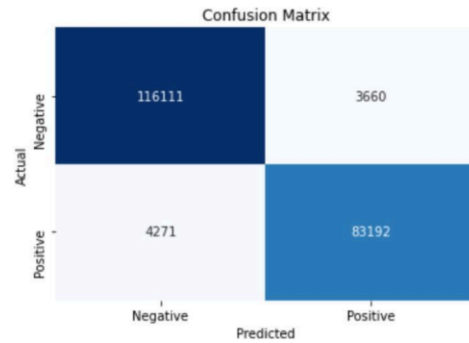
**Figure 4.10.** Confusion matrix of DT by taking CD

We can see here that the DT model by considering only CA was able to identify more TP and TN as compared to the DT model by considering only CD. If we compare with ARNN then ARNN was able to identify more TP and TN.



**Figure 4.11.** ROC curve of DNN by taking CA and CD

For our DNN model, the ROC curve by taking both CA and CD into consideration is better than the ROC of only CA and ROC of only CD. So DNN will be able to distinguish clearly between positive and negative classes more when both CA and CD are taken into consideration.



**Figure 4.12.** Confusion matrix of DNN by taking CA and CD

The confusion matrix of DNN by taking both CA and CD is identifying more TP and TN as compared to the confusion matrix of DNN by taking only CA and by considering only CD.

By observing all the above ROC curves and confusion matrices, we can say that the ARNN model is behaving much better than all other models.

From the above table, we can see that the accuracy of some of the previous work is

**Table 4.4.** Comparison of proposed work with state of the art method

Parameters	[11]	[2]	[12]	[13]	Proposed method
Features used	Raw ECG beats	ECG beats	HRV features, wavelet based features	HRV features	ECG signal
Classifier	multilayered RNN	MLDA-RNN	SVM	Multiscale Residual UNet++	MLDA-RNN
Evaluation Scheme	Train-Test split	Train-Test split	Train-Test split	Train-Test split	Blind data
Database used	BIDMC-CHF, PTBDB, and MIT-BIH NSRDB	STAFF III, PTB diagnostic	MIT-BIH Arrhythmia, BIDMC and MIT-BIH NSRD	NSR-RR, CHF-RR interval database	BIDMC, MIT-BIH NSRD
Accuracy	98.57%	97.79%	93.33%	89.83%	96.66%
Sensitivity	99.01%	—	—	—	96.229%
Specificity	97.89%	—	—	—	95.968%

better than our proposed work, but it is just because the evaluation scheme they have used is a train-test split method so in that case the model has some idea of our testing dataset. In our proposed method we are dividing our dataset into training and testing based on patients. So in this way, our model is completely unaware of the testing dataset. If compared to previous work, our model is giving very prominent results in such a case.

## 4.2 Result Interpretation

The experimental results show that the proposed MLDA-RNN model performs better than the conventional machine learning and deep neural network baselines used in this work. The main reason is that MLDA-RNN is designed for sequential ECG data. Unlike a decision tree, which makes decisions using fixed feature thresholds, the recurrent model learns how ECG patterns evolve over time. This is important because CHF-related abnormalities may not be visible in a single isolated sample but may become clear across a sequence of beats.

The attention component also enhances interpretability at the model level. This allows the network to concentrate more on the more useful temporal features. In ECG analysis, certain intervals may provide more powerful diagnostic information than others. For example, the QRS morphology and the irregularity of the rhythm may contain more information than relatively flat portions of the signal. The attention mechanism allows to use the signal in a more efficient way by giving different weights to different parts. One of the most important parts of the result is the evaluation in blind test. The test data contain subjects that are not seen during training, as patient-wise separation is employed. This makes the task more complicated, but also more meaningful. A model that does well on blind data is more likely to be generalizable to new patients. Therefore, the achieved accuracy of 96.06% suggests that the proposed method has learned useful disease-related patterns rather than merely memorized patient-specific characteristics.

## 4.3 Comparison with Baseline Models

The decision tree model provides a simple and interpretable baseline. It is easy to train and can indicate which features are important for classification. However, decision trees have limited capacity to model complex temporal relations because they partition the feature space using threshold-based rules and do not naturally learn long-range ECG dependencies. They therefore tend to perform worse on classification problems

that depend on sequential patterns. The deep neural network baseline improves on the decision tree by learning non-linear combinations of features. Dense layers can model complex relationships among input features, but they still treat the input as a fixed feature vector. A standard DNN may miss the sequential nature of ECG recordings unless temporal features are carefully engineered. This explains why the DNN performs better than the decision tree in some cases while remaining weaker than the attention-based recurrent approach.

The MLDA-RNN model has several advantages. It can process sequential ECG information, use multi-lead input, and focus on informative signal regions through attention. These properties make it more appropriate for CHF detection. The improvement in performance is especially significant because the evaluation is performed on blind patient-level data.

**Table 4.5.** Qualitative comparison of models used in this work

<b>Model</b>	<b>Strength</b>	<b>Limitation</b>	<b>Suitability for ECG</b>
Decision Tree	Simple and interpretable	Weak for complex temporal patterns	Suitable as a baseline
DNN	Learns nonlinear feature combinations	Does not naturally model sequence order	Useful when strong features are available
MLDA-RNN	Learns multi-lead temporal patterns with attention	Requires more training time and tuning	Highly suitable for CHF detection

#### 4.4 Clinical Relevance of the Results

The results support the feasibility of automated ECG-based CHF screening when the evaluation is performed on unseen subjects. In a practical workflow, a model of this type could highlight ECG segments that deserve closer review, provide a preliminary risk score, or support triage in remote monitoring settings. This is especially useful when continuous ECG data are available but expert review of every segment is not practical.

The system should, however, be interpreted strictly as decision support. CHF diagnosis requires clinical history, symptoms, examination findings, imaging, and laboratory information in addition to ECG. The proposed model can assist by producing alerts and prioritising review, but the final decision should remain with qualified med-

ical professionals. Validation on larger, multi-centre, and device-diverse datasets is necessary before clinical deployment.

#### **4.5 Error Analysis**

Errors may arise from signal noise, inter-patient variability, and overlap between normal and abnormal ECG morphology. A false positive may occur when a normal subject has rhythm or waveform characteristics that resemble pathological patterns. A false negative may occur when a CHF patient’s selected segment contains weak disease-specific evidence or is affected by preprocessing loss. These cases are important because medical decision-support systems must be both accurate and explainable.

In CHF screening, false negatives are particularly critical because they correspond to missed disease cases. Their frequency may be reduced by using longer windows, patient-level aggregation, repeated recordings, or additional clinical variables. False positives may increase follow-up workload, but they are generally less harmful than missed CHF cases. A deployed system could therefore tune the classification threshold toward higher sensitivity while maintaining acceptable specificity.

#### **4.6 Limitations of the Present Work**

Although the proposed method gives promising results, several limitations remain. First, the study relies on publicly available datasets whose patient count is smaller than what may be available in hospital-scale studies. Second, the present experiment is framed as binary classification between CHF and normal sinus rhythm. Real clinical populations may include arrhythmia, myocardial infarction, conduction abnormalities, medication effects, and other confounding conditions. Third, ECG acquisition settings can differ across devices, sampling rates, electrode placement, and recording environments, which may affect generalization.

Model interpretability is another limitation. Attention weights provide some indication of temporal emphasis, but they do not fully explain the physiological basis of every prediction. Future work should include saliency maps, lead-wise attention visualisation, beat-level contribution analysis, and clinician review of incorrectly classified examples.

#### **4.7 Practical Deployment Considerations**

Deployment would require more than the classification model alone. The first stage should assess signal quality so that noisy or incomplete ECG windows are rejected, re-recorded, or marked as uncertain. Accepted segments can then pass through pre-processing, Integer Haar Wavelet Transform feature extraction, and MLDA-RNN inference. In a clinical interface, the output should preferably be a calibrated risk score with confidence information rather than only a binary label.

Privacy and security are also central concerns because ECG recordings are sensitive health data. Cloud-based processing would require encryption, access control, and secure storage. On-device processing can reduce communication cost and limit exposure of raw ECG data, which is relevant for wearable systems. The compact feature representation produced by Integer Haar Wavelet Transform and the use of GRU-based sequence modelling make such deployment more realistic.

Patient-level aggregation is another practical enhancement. Instead of basing the decision on a single segment, predictions from multiple windows can be combined over time. This approach can reduce the influence of noisy or uncertain segments and produce a more stable final assessment during long-term monitoring.

## CONCLUSION AND FUTURE WORK

### 5.1 Conclusion

This dissertation presented an ECG-based approach for congestive heart failure detection using signal-processing features and machine learning models. The study began with the clinical need for automated CHF screening, reviewed prior ECG classification methods, and described the BIDMC and MIT-BIH datasets used for experimentation. The methodology covered preprocessing, patient-wise data separation, Integer Haar Transform feature extraction, and classification using baseline models and the proposed MLDA-RNN. Among the evaluated models, MLDA-RNN achieved the highest blind-test accuracy of 96.06%.

A key contribution of the work is the use of patient-wise testing. Rather than randomly mixing ECG segments, complete patient recordings were assigned to training, validation, or testing groups. This setting is more difficult because the model must classify subjects that were not observed during training. The result is therefore more meaningful for practical screening than a segment-level random split. The performance of the attention-based recurrent model suggests that temporal multi-lead ECG information is useful for CHF recognition under a stricter evaluation protocol.

### 5.2 Future Work

Future work can extend the present study in the following directions:

- Extend the model from binary screening to multi-class classification involving CHF severity levels and other cardiac conditions.
- Evaluate the approach on larger, multi-centre, and device-diverse ECG datasets to measure generalization more reliably.
- Implement the Integer Haar Wavelet Transform feature extraction stage on low-power wearable hardware.

- Compare the current attention mechanism with advanced recurrent, convolutional, and transformer-based sequence models.
- Combine ECG-derived features with clinical variables such as symptoms, imaging findings, and laboratory measurements.

## BIBLIOGRAPHY

- [1] M. Janveja and G. Trivedi, "An area and power efficient VLSI architecture for ECG feature extraction for wearable IoT healthcare applications," *Integration*, vol. 82, pp. 96–103, 2022.
- [2] E. Prabhakararao and S. Dandapat, "Myocardial infarction severity stages classification from ECG signals using attentional recurrent neural network," *IEEE Sensors Journal*, vol. 20, no. 15, pp. 8711–8720, 2020.
- [3] G. Lippi and F. Sanchis-Gomar, "Global epidemiology and future trends of heart failure," *AME Medical Journal*, vol. 5, 2020.
- [4] P. Melillo, N. De Luca, M. Bracale, and L. Pecchia, "Classification tree for risk assessment in patients suffering from congestive heart failure via long-term heart rate variability," *IEEE Journal of Biomedical and Health Informatics*, vol. 17, no. 3, pp. 727–733, 2013.
- [5] U. Orhan, "Real-time CHF detection from ECG signals using a novel discretization method," *Computers in Biology and Medicine*, vol. 43, no. 10, pp. 1556–1562, 2013.
- [6] Z. Mašetić and A. Subasi, "Detection of congestive heart failures using C4.5 decision tree," *Southeast Europe Journal of Soft Computing*, vol. 2, pp. 74–77, 2013.
- [7] Y. Isler, A. Narin, M. Ozer, and M. Perc, "Multi-stage classification of congestive heart failure based on short-term heart rate variability," *Chaos, Solitons & Fractals*, vol. 118, pp. 145–151, 2019.
- [8] Y. N. Fuadah and K. M. Lim, "Optimal classification of atrial fibrillation and congestive heart failure using machine learning," *Frontiers in Physiology*, vol. 12, 2022.
- [9] U. R. Acharya, H. Fujita, S. L. Oh, Y. Hagiwara, J. H. Tan, M. Adam, and R. S. Tan, "Deep convolutional neural network for the automated diagnosis of congestive heart failure using ECG signals," *Applied Intelligence*, vol. 49, 2019.

- [10] A. Darmawahyuni, S. Nurmaini, M. Yuwandini, M. N. Rachmatullah, F. Masdung, and B. Tutuko, "Congestive heart failure waveform classification based on short time-step analysis with recurrent network," *Informatics in Medicine Unlocked*, vol. 21, 2020.
- [11] E. Prabhakararao and S. Dandapat, "Congestive heart failure detection from ECG signals using deep residual neural network," *IEEE Transactions on Systems, Man, and Cybernetics: Systems*, vol. 53, no. 5, pp. 3008–3018, 2023.
- [12] S. Nahak and G. Saha, "A fusion based classification of normal, arrhythmia and congestive heart failure in ECG," in *2020 National Conference on Communications (NCC)*, 2020, pp. 1–6.
- [13] L. Zou, Z. Huang, X. Yu, J. Zheng, A. Liu, and M. Lei, "Automatic detection of congestive heart failure based on multiscale residual UNet++: From centralized learning to federated learning," *IEEE Transactions on Instrumentation and Measurement*, vol. 72, pp. 1–13, 2023.
- [14] T. Liu, Y. Si, W. Yang, J. Huang, Y. Yu, G. Zhang, and R. Zhou, "Inter-patient congestive heart failure detection using ECG-convolution-vision transformer network," *Sensors*, vol. 22, no. 9, p. 3283, 2022.
- [15] M. R. Prusty, T. N. Pandey, P. S. Lekha, G. Lellapalli, and A. Gupta, "Scalar invariant transform based deep learning framework for detecting heart failures using ECG signals," *Scientific Reports*, vol. 14, p. 2765, 2024.
- [16] A. Mahmoud *et al.*, "Electrocardiogram signals classification using deep-learning-based incorporated convolutional neural network and long short-term memory framework," *Computers*, vol. 13, no. 2, p. 55, 2024.
- [17] I. Odinaka *et al.*, "Cardiac arrhythmia detection using deep learning and time-frequency representation of ECG signals," *BMC Medical Informatics and Decision Making*, vol. 23, p. 230, 2023.
- [18] S. M. Lee, T. Kim, M. Shin, J.-O. Choi, M. J. Chung, and D. Kim, "Deep learning algorithm for detection of acute heart failure using standard ECG waveforms," *European Heart Journal – Digital Health*, 2025.

## ORIGINALITY REPORT

8%

SIMILARITY INDEX

5%

INTERNET SOURCES

6%

PUBLICATIONS

4%

STUDENT PAPERS

## PRIMARY SOURCES

1	<a href="https://dspace.dtu.ac.in:8080">dspace.dtu.ac.in:8080</a> Internet Source	1%
2	Rushik Parmar, Meenali Janveja, Jan Pidanic, Gaurav Trivedi. "Design of DNN-Based Low-Power VLSI Architecture to Classify Atrial Fibrillation for Wearable Devices", IEEE Transactions on Very Large Scale Integration (VLSI) Systems, 2023 Publication	<1%
3	Terzi, Merve Begüm. "Artificial Intelligence-Based Hybrid Anomaly Detection and Clinical Decision Support Techniques for Automated Detection of Cardiovascular Diseases and COVID-19.", Bilkent Universitesi (Turkey) Publication	<1%
4	Paolo Ferro, Harinadh Vemanaboina, Chander Prakash. "Computational Techniques and Smart Manufacturing", CRC Press, 2026 Publication	<1%
5	Submitted to dtusimilarity Student Paper	<1%
6	L. B. Fertig, J. H. McClellan. "Frequency Modulation", Wiley, 1999 Publication	<1%
7	<a href="http://gyan.iitg.ac.in">gyan.iitg.ac.in</a> Internet Source	<1%

8

Fatih Yucalar. "Developing an Advanced Software Requirements Classification Model Using BERT: An Empirical Evaluation Study on Newly Generated Turkish Data", Applied Sciences, 2023

Publication

<1 %

9

[www.hindawi.com](http://www.hindawi.com)

Internet Source

<1 %

10

[functions.boardflare.com](http://functions.boardflare.com)

Internet Source

<1 %

11

"Smart Trends in Computing and Communications", Springer Science and Business Media LLC, 2024

Publication

<1 %

12

Alrokhaimi, Khalid. "An Interpretable Machine Learning Framework for Detecting Phishing URLs Based on Lexical Features", Rochester Institute of Technology, 2025

Publication

<1 %

13

Qiang Zhu, Xingpeng Jiang, Qing Zhu, Min Pan, Tingting He. "Graph Embedding Deep Learning Guides Microbial Biomarkers' Identification", Frontiers in Genetics, 2019

Publication

<1 %

14

Thangaprakash Sengodan, Sanjay Misra, M Murugappan. "Advances in Electrical and Computer Technologies", CRC Press, 2025

Publication

<1 %

15

Vishnu Venkatesh, S. Angalaeswari, Aravindkumar Sekar. "ASNet: Attention-stacked deep network for ECG-based cardiac rhythm classification", Biomedical Signal Processing and Control, 2026

Publication

<1 %

16	Submitted to Westcliff University Student Paper	<1 %
17	escholarship.org Internet Source	<1 %
18	Submitted to Universiti Tenaga Nasional Student Paper	<1 %
19	ebin.pub Internet Source	<1 %
20	Submitted to Kotebe University Student Paper	<1 %
21	www.bspublications.com Internet Source	<1 %
22	Submitted to Delhi Technological University Student Paper	<1 %
23	Mina Ghaffari, Gihan Samarasinghe, Michael Jameson, Farhannah Aly et al. "Automated post-operative brain tumour segmentation: A deep learning model based on transfer learning from pre-operative images", Magnetic Resonance Imaging, 2021 Publication	<1 %
24	Submitted to University of North Texas Student Paper	<1 %
25	Submitted to University of Surrey Student Paper	<1 %
26	kipdf.com Internet Source	<1 %
27	lisa.unical.it Internet Source	<1 %
28	Submitted to Indian Institute of Technology Patna	<1 %

**29** Submitted to JIS University <1 %  
Student Paper

---

**30** illinois-general-assembly22.blogspot.com <1 %  
Internet Source

---

**31** www.nature.com <1 %  
Internet Source

---

**32** "Evolution in Computational Intelligence",  
Springer Science and Business Media LLC,  
2025 <1 %  
Publication

---

**33** Submitted to RMIT University <1 %  
Student Paper

---

**34** digibug.ugr.es <1 %  
Internet Source

---

**35** thelinuxcode.com <1 %  
Internet Source

---

**36** www.biorxiv.org <1 %  
Internet Source

---

Exclude quotes  On

Exclude matches  < 14 words

Exclude bibliography  On

FINAL GRADE

GENERAL COMMENTS

**/0**

---

PAGE 1

---

PAGE 2

---

PAGE 3

---

PAGE 4

---

PAGE 5

---

PAGE 6

---

PAGE 7

---

PAGE 8

---

PAGE 9

---

PAGE 10

---

PAGE 11

---

PAGE 12

---

PAGE 13

---

PAGE 14

---

PAGE 15

---

PAGE 16

---

PAGE 17

---

PAGE 18

---

PAGE 19

---

PAGE 20

---

PAGE 21

---

PAGE 22

---

PAGE 23

---

PAGE 24

---

PAGE 25

---

PAGE 26

---

PAGE 27

---

PAGE 28

---

PAGE 29

---

PAGE 30

---

PAGE 31

---

PAGE 32

---

PAGE 33

---

PAGE 34

---

PAGE 35

---

PAGE 36

---

PAGE 37

---

PAGE 38

---

PAGE 39

---

PAGE 40

---

PAGE 41

---

PAGE 42

---

PAGE 43

---

PAGE 44

---

PAGE 45

---

PAGE 46

---

PAGE 47

---

PAGE 48

---

PAGE 49

---

PAGE 50

---

PAGE 51

---

PAGE 52

---