

main (2).pdf

 Birla Institute of Technology, Mesra

Document Details

Submission ID

trn:oid::3117:598733231

Submission Date

Jun 9, 2026, 9:09 PM GMT+5:30

Download Date

Jun 9, 2026, 9:21 PM GMT+5:30

File Name

main (2).pdf

File Size

743.4 KB

79 Pages

15,298 Words

82,821 Characters





4% Overall Similarity

The combined total of all matches, including overlapping sources, for each database.



Filtered from the Report

- ▶ Bibliography
- ▶ Small Matches (less than 14 words)

Match Groups

-  **17 Not Cited or Quoted 3%**
Matches with neither in-text citation nor quotation marks
-  **1 Missing Quotations 0%**
Matches that are still very similar to source material
-  **2 Missing Citation 0%**
Matches that have quotation marks, but no in-text citation
-  **0 Cited and Quoted 0%**
Matches with in-text citation present, but no quotation marks

Top Sources

- 3%  Internet sources
- 1%  Publications
- 0%  Submitted works (Student Papers)

Integrity Flags

0 Integrity Flags for Review

No suspicious text manipulations found.

Our system's algorithms look deeply at a document for any inconsistencies that would set it apart from a normal submission. If we notice something strange, we flag it for you to review.

A Flag is not necessarily an indicator of a problem. However, we'd recommend you focus your attention there for further review.

Match Groups

- **17 Not Cited or Quoted 3%**
Matches with neither in-text citation nor quotation marks
- **1 Missing Quotations 0%**
Matches that are still very similar to source material
- **2 Missing Citation 0%**
Matches that have quotation marks, but no in-text citation
- **0 Cited and Quoted 0%**
Matches with in-text citation present, but no quotation marks

Top Sources

- 3% ■ Internet sources
- 1% ■ Publications
- 0% ■ Submitted works (Student Papers)

Top Sources

The sources with the highest number of matches within the submission. Overlapping sources will not be displayed.

1	Internet	dspace.dtu.ac.in:8080	2%
2	Internet	www.dspace.dtu.ac.in:8080	<1%
3	Publication	Yumna Mansoor, Faizan Zahid, Ghulam-E-Mustafa Abro, Syed Saad Azhar, Summa...	<1%
4	Publication	"Proceedings of the 13th National Technical Seminar on Unmanned System Tech...	<1%
5	Publication	Abir Muhtadi, Ahmed Mortuza Saleque. "A performance study based on compara...	<1%
6	Internet	www.shunlongwei.com	<1%
7	Internet	psecommunity.org	<1%
8	Internet	injoqast.net	<1%
9	Publication	Sanyasi Nayudu G, Ravisankar Kampara, Venkateswaran M, Parusharamulu Budu...	<1%
10	Internet	brightideas.houstontx.gov	<1%

11 Internet

ijfs.usb.ac.ir <1%

12 Internet

ijsrem.com <1%

13 Internet

www.palveluskoiraliitto.fi <1%

Energy-Efficient Solar Water Pumping And The Role Of DC-DC Boost Converters In Addressing Water Scarcity

A DISSERTATION

SUBMITTED IN PARTIAL FULFILLMENT OF THE REQUIREMENTS
FOR THE AWARD OF THE DEGREE
OF
MASTER OF TECHNOLOGY
IN
CONTROL & INSTRUMENTATION

Submitted by

VARDAAN SINGH THAKUR
(2K24/C&I/17)

Under the supervision of

Prof. DHEERAJ JOSHI
Dr. BHAVNESH JAINT

Department of Electrical Engineering



DEPARTMENT OF ELECTRICAL ENGINEERING
DELHI TECHNOLOGICAL UNIVERSITY
(Formerly Delhi College of Engineering)
Bawana Road, Delhi 110042

MAY, 2026

M.TECH (Control & Instrumentation) VARDAAAN SINGH THAKUR

2026

DEPARTMENT OF ELECTRICAL ENGINEERING
DELHI TECHNOLOGICAL UNIVERSITY
(Formerly Delhi College of Engineering)
Bawana Road, Delhi-110042

CANDIDATE'S DECLARATION

I, Vardaan Singh Thakur, Roll No. 2K24/C&I/17 student of M.Tech (Control & Instrumentation), hereby declare that the project Dissertation titled **“Energy-Efficient Solar Water Pumping And The Role Of DC-DC Boost Converters In Addressing Water Scarcity”** which is submitted by me to the Department of Electrical Engineering, Delhi Technological University, Delhi in partial fulfilment of the requirement for the award of degree of Master of Technology, is original and not copied from any source without proper citation. This work has not previously formed the basis for the award of any Degree, Diploma Associateship, Fellowship or other similar title or recognition.

Place: Delhi

Vardaan Singh Thakur

Date:

DEPARTMENT OF ELECTRICAL ENGINEERING
DELHI TECHNOLOGICAL UNIVERSITY
(Formerly Delhi College of Engineering)
Bawana Road, Delhi-110042

CERTIFICATE

I hereby certify that the Project Dissertation titled “**Energy-Efficient Solar Water Pumping And The Role Of DC-DC Boost Converters In Addressing Water Scarcity**” which is submitted by Vardaan Singh Thakur, Roll No. 2K24/C&I/17, Electrical Engineering Department, Delhi Technological University, Delhi in partial fulfillment of the requirement for the award of the degree of Master of Technology, is a record of the project work carried out by the student under my supervision. To the best of my knowledge this work has not been submitted in part or full for any Degree or Diploma to this University or elsewhere.

Place: Delhi

Prof. Dheeraj Joshi
SUPERVISOR

Date:

Department of Electrical Engineering
Delhi Technological University

Dr. Bhavnesh Jaint
SUPERVISOR

Department of Electrical Engineering
Delhi Technological University

1

DEPARTMENT OF ELECTRICAL ENGINEERING
DELHI TECHNOLOGICAL UNIVERSITY
(Formerly Delhi College of Engineering)
Bawana Road, Delhi-110042

ACKNOWLEDGEMENT

I take immense pleasure in expressing my deep and sincere gratitude to my esteemed supervisor, **Prof. Dheeraj Joshi and Dr. Bhavnesh Jain**, for invaluable guidance and for dedicating precious hours to my work. Their excellent cooperation, constructive suggestions, and stimulating discussions provided me with the impetus to work rigorously and made the completion of this thesis possible.

1 I am grateful to the Department of Electrical Engineering, Delhi Technological University, for providing access to computational resources and for maintaining a research oriented academic environment that enabled this work.

I appreciate and heartily thank all the faculty members of the Department of Electrical Engineering and all my colleagues for their constant support and encouragement throughout the research. Finally, yet importantly, I would like to pay high regards to my parents, family members, and friends for their inspiration, motivation, and patience throughout the duration of this work. Their unwavering support has been the foundation upon which this thesis rests.

Place: Delhi

Vardaan Singh Thakur

Date:

Abstract

Water scarcity hits hard in dry and remote areas where people rely on farming. Getting water is tough when the grid power is missing or diesel options end up too expensive and bad for the air. Solar panels seem like a way forward for pumping but the light changes all day and clouds mess things up so the panels never give steady output. Without something to manage that the pump runs poorly and wears out faster.

This project looks at adding a boost converter with MPPT to a solar setup. The converter lifts the voltage from the panels to something the motor can use steadily. At the same time the tracking part keeps pulling the most power possible even when sunlight shifts or temperature changes. I think that helps the whole thing run better than just hooking panels straight to the pump. There is also some control for how fast the pump spins based on power available and a few safety bits like stopping it if current gets too high.

Simulations checked how it behaves when light jumps around or part of the array gets shaded. Results showed the tracking efficiency stays high most of the time above 95 percent in the tests. Water output went up for the same panel size and the motor did not stall as easily during quick changes. Voltage stayed more level overall. One thing that still feels unclear is exactly how much extra water you get on really cloudy days compared to other systems.

Keywords: Solar photovoltaic (PV); DC-DC boost converter; Maximum Power Point Tracking (MPPT); energy-efficient water pumping; off-grid irrigation; water scarcity; voltage regulation; pump performance

1

Contents

13

Candidate’s Declaration	ii
Certificate	iii
Acknowledgement	iv
Abstract	v
Content	vii
List of Tables	viii
List of Figures	ix
List of Symbols, Abbreviations	x
1 INTRODUCTION	1
1.1 Role of solar PV in water pumping	1
1.2 Importance of DC-DC Boost Converters	2
1.2.1 Voltage Control & Stability	2
1.2.2 Enabling Maximum Power Point Tracking (MPPT)	3
1.2.3 Enhanced Energy Extraction & System Benefits	4
1.3 MPPT (Maximum Power Point Tracking) Integration	4
2 LITERATURE REVIEW	6
2.1 The Global Water Scarcity Crisis: Context & Urgency	6
2.2 The failure of traditional water pumping solutions	7
2.3 The promise of solar photovoltaic(PV) water pumping	9
2.4 Technical challenges & the need for system-level advancements	10
2.5 Purpose of Literature Review	12
3 STATE OF THE ART APPROACHES	14
3.1 Highly advanced DC-DC Converter circuits & H/W for Solar water pumping	14
3.1.1 High-Gain, Interleaved, & Multilevel Boost Topologies	15
3.1.2 Soft-Switching & Resonant Techniques	17
3.1.3 Wide Bandgap Devices: SiC & GaN	20
3.2 Cutting-Edge MPPT Methods	23
3.2.1 The Constraints of Classical MPPT	23
3.2.2 Hybrid & Adaptive MPPT Algorithms	24
3.2.3 Meta-Heuristic & Machine Learning MPPT Methods	26

- 3.2.4 Fast & Robust Tracking in Dynamic Solar Pumping Applications 27
- 3.3 Energy Buffering & Power-Management Strategies 30
 - 3.3.1 The mismatch of Solar Energy Supply with pump hydraulic Or Electrical Power Demands 30
 - 3.3.2 Supercapacitor Buffering & Pulsed Pumping 32
 - 3.3.3 Hybrid Systems (PV + BATTERY + Grid/Wind) 34
 - 3.3.4 Intelligent Energy Management System for Multiple Energies Sources 36
- 3.4 Partial-Shading Mitigation & PV Array Management 38
 - 3.4.1 The Destructive Effects of Partial Shading 38
 - 3.4.2 Current Mitigation Technologies for Partial Shade Problem . . 38
 - 3.4.3 Module Level Power Electronics (MLPE) 38
 - 3.4.4 Micro Inverters for AC Pumping Systems 39
 - 3.4.5 Reconfigurable Array Topologies 40
 - 3.4.6 Local MPPT per Sub-String (Distributed MPPT) 43
 - 3.4.7 COMPARATIVE ANALYSIS: Solar Water Pumping Vs. Electric Water Pumping 44
 - 3.4.8 Working Principle Of Solar Water Pumping System 48
- 4 SIMULATION RESULTS AND DISCUSSION 52**
 - 4.1 Simulation Setup 52
 - 4.2 Output Power Waveforms under Variable Irradiance 55
 - 4.2.1 Description of the Output Power (P_0) Waveform 55
 - 4.2.2 Key Observations 57
 - 4.3 High-Resolution View of Output Power Response 58
 - 4.3.1 Description of the Output Power Waveform 58
 - 4.3.2 Key Observations 60
 - 4.4 MPPT Algorithm Used for Above Waveform 61
- 5 CONCLUSION 63**
 - 5.1 Limitations of the Implemented INC MPPT System 63
 - 5.1.1 Fixed Duty Cycle Limits (0.60–0.70) 64
 - 5.1.2 Noise Sensitivity in Measurements 64
 - 5.1.3 Slow Response Time for Instantaneous Change in Irradiance . 64

List of Tables

3.1	Advanced Topologies and Technologies	23
3.2	Review of Recent Comparative Studies	29
3.3	Comparison of Energy Buffering Technologies	32
3.4	Experimental Results for Pumping Modes	34
3.5	PV-Battery System Sizing Considerations	35
3.6	Resource and System Comparison	36
3.7	Energy Buffering and Power-Management Strategies	37
3.8	Consequences of Shading Scenarios	38
3.9	Benefits of Module-Level Power Electronics	39
3.10	DC Optimizers vs. Microinverters for Pumping	40
3.11	Optimization Algorithms for Reconfiguration	43
3.12	Comparison of MPPT Architectures	44
3.13	Initial Investment (Capital Cost)	45
3.14	Documented Life Cycle Cost Comparison (25-year lifespan)	46
3.15	Performance and Reliability Comparison	46
3.16	Summary Comparison Table	47
3.17	Pump types and applications	50
4.1	Block Parameter PV Array	54

List of Figures

3.1	Purposed Solar Water Pumping System	48
4.1	Block Diagram of the Solar Water Pumping System	52
4.2	Simulation Setup of the Solar Water Pumping System	53
4.3	Output Power Waveforms under Variable Irradiance	55
4.4	High-Resolution View of Output Power Response	58
4.5	Flowchart of the Implemented Incremental Conductance Algorithm . .	61

List of Symbols, Abbreviations

PV	Photovoltaic
MPPT	Maximum Power Point Tracking
MPP	Maximum Power Point
GMPP	Global Maximum Power Point
LMPP	Local Maximum Power Point
P&O	Perturb and Observe
INC	Incremental Conductance
FLC	Fuzzy Logic Control
ANN	Artificial Neural Network
PSO	Particle Swarm Optimization
GWO	Grey Wolf Optimizer
NN	Neural Network
ML	Machine Learning
MLPE	Module Level Power Electronics
DMPPT	Distributed Maximum Power Point Tracking
EMS	Energy Management System
BLDC	Brushless Direct Current
PMSM	Permanent Magnet Synchronous Motor
PMDC	Permanent Magnet Direct Current
VFD	Variable Frequency Drive
SiC	Silicon Carbide
GaN	Gallium Nitride
ZVS	Zero Voltage Switching
ZCS	Zero Current Switching
EMI	Electromagnetic Interference
PWM	Pulse Width Modulation
MOSFET	Metal Oxide Semiconductor Field Effect Transistor
IGBT	Insulated Gate Bipolar Transistor
SOC	State of Charge
LCC	Life Cycle Cost
<i>D</i>	Duty cycle
V_{in}	Input voltage, <i>V</i>
V_{out}	Output voltage, <i>V</i>
V_{oc}	Open circuit voltage, <i>V</i>
I_{sc}	Short circuit current, <i>A</i>
V_{mp}	Voltage at maximum power point, <i>V</i>
I_{mp}	Current at maximum power point, <i>A</i>
P_0	Output power, <i>W</i>

ΔV	Change in voltage
ΔI	Change in current
dP/dV	Power derivative with respect to voltage
$R_{ds(on)}$	Drain-source on-resistance
Q_g	Gate charge
Q_{rr}	Reverse recovery charge

CHAPTER 1

INTRODUCTION

1.1 Role of solar PV in water pumping

Since October 2023, photovoltaic (PV) solar power systems have proven to be a game changer in providing energy for water pumping [1]. In many parts of the world, the availability of dependable electric power or low-cost fossil fuels is not present. The solar PV module itself is an electronic device that generates electrical energy from light through the photoelectric effect. This provides a number of advantages for the application of PV systems to pumping water.

There is no fuel used for solar photovoltaic (PV) water pumps. Pumps powered by Diesel or gas are continually being provided with fuel that can be costly and may have to be transported over rough terrain. On the other hand, the energy from the sun can be used as an Energy Source that has no cost associated therewith. The result is that if you had a solar PV water pump, you would not incur operational costs associated with fluctuations in fuel prices. Additionally, solar PV Water Pumps require a minimum of maintenance. The pump and motor are the only moving components of a PV water pump, in contrast to diesel or gas-powered pumps, which have numerous moving elements. As a result, the vibration, combustion, and friction brought on by the movement of their components generate extremely minimal wear and tear on these pumps. Maintaining the solar PV Water Pump's functionality only requires cleaning its panels and inspecting its electrical connections [2]. Solar PV water pumps work particularly well in remote areas where obtaining repair service and parts can be very difficult. Lastly, a properly designed solar photovoltaic (PV) system can provide decades of operation before needing a major repair. The only

item that will need to be replaced is the pump, motor and possibly the battery.

Solar photovoltaic panels do provide many advantages, but there is still a large degree of variability and interruptions with their output. The electrical power produced from solar photovoltaic panels does not stay the same; it varies widely due to multiple factors such as environmental and operational influences. The major environmental factor is the solar radiation that hits the panels, or solar irradiance.

The higher the temperature of the solar photovoltaic panel, the lower the voltage produced and subsequently will result in lower amounts of electricity produced from the solar photovoltaic panel, even though common wisdom would lead one to believe that increasing temperatures would increase voltage output. There is also a wide range of differences in electrical characteristics between solar photovoltaic cells or panels manufactured by the same manufacturer due to manufacturing tolerances and partial shading caused by trees, leaves, etc. The result of solar photovoltaic module mismatch can result in inefficiency and a reduction in the overall amount of electricity produced from arrays.

The above changes are bound to have direct repercussions on the pumping system. The motor has to work at a constant voltage level and current to achieve steady torque and rotational speed.

1.2 Importance of DC-DC Boost Converters

A DC-DC boost converter is an electronic circuit that converts a variable low voltage DC power into constant high voltage DC power. It is used for the boosting purposes of providing a constant voltage suitable for powering the motor in the water pump. Its purpose is much more than just being convenient; it is very crucial in the design and operation of effective solar pumping systems [3].

1.2.1 Voltage Control & Stability

The most difficult problem that comes out in applying the directly coupled solar pump system is the low voltage across the panels relative to the input voltage of the

motor during morning, evening, and cloudy periods. A regular 12V or 24V pump would simply not start in cases where the voltage supplied by the panels drops to 10V or 18V respectively. By means of using an inductor, switching transistor (MOSFET in particular), [4] diode, and a capacitor, the boost converter is capable of storing energy supplied through the low voltage input and delivering the energy at high voltage. This is made possible through the switching action carried out by the switching transistor. While the switch is on, energy is stored by the inductor in its magnetic field, while off, it discharges into the load, thereby increasing the input voltage.

Firstly, voltage regulation results in increased efficiency due to the fact that the pump will always have access to constant voltage supply regardless of any input variations.

1.2.2 Enabling Maximum Power Point Tracking (MPPT)

Inextricably intertwined with the MPPT algorithm is the boost converter circuit. It is responsible for providing the hardware implementation of the MPPT algorithm. Almost all commonly used MPPT algorithms—the widely employed but relatively basic P&O [4, 5], the less unstable INC algorithm [6], and sophisticated methods such as Fuzzy Logic or Neural Networks—are implemented through the adjustment of the duty cycle (D) of the boost converter's transistor. As stated earlier, the duty cycle is simply the ratio of the time spent in the On state of the transistor against its Off state, e.g., 50% duty cycle meaning it remains On for half the time and Off for the other half. With this control of the duty cycle, an MPPT controller manipulates the impedance (or electrical load) that appears to the solar panel. As already stated, MPPT works by ensuring that the impedance of the solar panel matches that of the load (pump) at the point where the former generates its peak power output.

1.2.3 Enhanced Energy Extraction & System Benefits

9

The efficiency of energy harnessing is greatly improved through the use of the **boost converter**, by **ensuring that the PV panel operates at its maximum power point**. The pump, which would otherwise obtain energy from a non-optimum point along the PV graph (possibly higher or lower than the optimal voltage for the panel) gets its energy from the maximum point along the graph.

There are definite advantages of this, which include an improvement in energy harnessed by up to 20–35% when compared to the direct coupled model, and possibly greater during periods of cloudiness and changeable weather. Increased energy means an increased output in terms of water pumping per day, with liters or gallons per day being increased. Additionally, the elimination of electrical spikes, current surges, and other problems encountered in the direct coupled model results in less electrical strain being exerted on the motor windings.

1.3 MPPT (Maximum Power Point Tracking) Integration

Keep in mind that if you have a good quality solar water pump, you should have an MPPT system, as it is not a feature that can be done without. Every solar panel has a specific I-V curve associated with it. At any level of radiation or temperature, there is always one MPP where the current and voltage multiply to their highest value. Using a direct connection between the pump and the solar panel puts the pump at a point on the panel's I-V curve that will not, in most cases, equate to the MPP, thus providing inefficient operation from the panel.

Why is it impossible to find the MPP? The reason is that the MPP is moving constantly as the irradiance and temperature of the solar panels change throughout the day and cause the shape of the curve and MPP locations to change. As a result, the voltage and current associated with the MPP will be changing constantly and a hardwired connection cannot account for that.

There are several algorithms that can help control MPPT systems. Examples

include:

- 11 • **Perturb & Observe (P&O):** This simple algorithm works by slightly “perturbing” (changing) the operating voltage and then “observing” whether the power increases or decreases. If power increases, it continues perturbing in the same direction; if power decreases, it reverses direction. While effective, P&O can oscillate around the MPP and become confused during rapid irradiance changes [4, 7].
- **Incremental Conductance (INC):** This more sophisticated algorithm compares the incremental conductance (the instantaneous rate of change of current with respect to voltage) to the instantaneous conductance (current divided by voltage). At this point, both forces are equal and opposite to each other [6].

Why is Incremental Conductance (INC) preferred in solar water pumping applications? There are several important reasons why Incremental Conductance (INC) is preferable in the water pumping application:

1. **Stability under Rapidly Changing Irradiance:** Water pumps are frequently used in an environment where the presence of clouds or shadow causes extremely fast irradiance changes. INC handles these dynamic conditions much better than P&O because it can mathematically determine whether a change in power is due to its own perturbation or due to an external environmental shift. This prevents it from “hunting” in the wrong direction.
2. **Synergy with Boost Converters:** The control logic of INC aligns very cleanly with the duty-cycle control of a boost converter, allowing for efficient and precise tracking without excessive computational overhead.

CHAPTER 2

LITERATURE REVIEW

2.1 The Global Water Scarcity Crisis: Context & Urgency

Water scarcity is no longer a local challenge, but it is now one of the biggest problems in the rural and agricultural societies across the world. While accessing water in urban places might rely on complex infrastructure systems, rural and agricultural societies access water directly from the source for domestic purposes and for irrigation. There are a lot of consequences caused by a deficiency in availability of water which can result in lower levels of productivity, an inability to earn a living, migration of people, or even a conflict between people. According to various global organisations, such as UN-Water, UNESCO and WHO, numerous comprehensive research projects have been conducted to determine how many people around the globe experience a lack of water or stress due to a lack of water every single month for one year. **The total amount of people who are living under conditions of water stress exceeds 2 billion people throughout the entire world [1, 2].** This is a significant percentage of the world's together if we take into consideration that almost 1/4 of the total number of people in the world are living under such conditions. However, statistics also predict an increase in these numbers in the future years owing to three major factors which include:

Population Increase: There will be more people in the world by 2050 than ever before—an estimated 10 billion. This mass growing means a large increase

in usage of fresh water including for drinking, washing, growing crops and getting industrial work done. Fresh water supply has stayed the same even as population increases and requires more fresh water supply.

Changes in Climate: Climate change causes the globe to shift from one weather pattern system to another, including increased and quicker melting of glaciers or ice caps that supply rivers with fresh water, droughts and many other changes that weaken the hydrological cycle. Rain is also falling less frequently and not as reliably as it used to in many areas making it much more risky to raise crops on the seasonal rain. Plus, evaporation rates from lakes and soil have also increased.

Depleting Aquifers or Groundwater: Located in many regions around the world, such as Ogallala Aquifer located in U.S. High Plains; Indo-Gangetic Plain located in India; and North China Plain, people are removing groundwater faster than the rate at which groundwater is naturally recharged. This is referred to as “mining” or depletion of aquifers or fossil groundwater. Every time farmers must look underground to access ground water they have to create deeper wells which equates to spending more time and money lifting the water.

2.2 The failure of traditional water pumping solutions

In recent decades, diesel engines and electric motors connected to the grid have been the two predominant technologies for pumping water in rural and agricultural applications. However, as we examine them based on cost, environmental impacts and how well the systems operate, both technologies prove to be insufficient[8] in a world where they are increasingly becoming economically, environmentally and operationally unviable are the use of diesel engines and the use of electric motors connected to the grid.

While diesel pumping systems have gained widespread acceptance among users

due to portability, higher power output per unit compared to electric motors, and independence from the electrical grid, they have multiple disadvantages including:

Diesel engines are not economically sustainable, since the cost of diesel fuel is subject to fluctuations in global pricing for crude oil and increases in transportation expenses due to the poor road infrastructure used to deliver fuel into remote rural communities can result in diesel fuel being priced anywhere between two and three times higher once it reaches a farmer's pump than what the farmer paid at the fuel terminal. Farmers often spend a significant percentage of their operating expenses to purchase diesel fuel.

Diesel engines require continuous and costly maintenance (i.e., changing engine oil and fuel filters, cleaning fuel injectors and doing major repairs) which is frequently very difficult because remote rural villages often do not have easy access to spare parts or experienced diesel mechanics.

Diesel pumping systems are harmful to the environment. They emit carbon dioxide (greenhouse gas), nitrogen oxides, and unburned hydrocarbons into the air and particulate matter; contributing to ambient pollution, respiratory disease and global weather change. Diesel also generates loud noise pollution that can negatively affect animals and communities. Electric Pumping Systems that are tied into the grid are much cleaner, but there are several other limitations compared to diesel pumping systems. In numerous rural areas in the developing world, the grid either does not exist, is unstable or poorly developed. Even when it does, power outages (load shedding), brownouts with voltage fluctuations, and poor frequency stability will frequently occur. These conditions can cause difficulties with overheating and/or failure of electric motors. Electric pumping systems will potentially have high operating costs for farmers who are required to pay for the inefficiency, high distribution loss and lack of subsidies to residential and commercial electric users.

Farmers have been known to illegally tap power lines, which can result in dangerous conditions and further instability of the electric grid.

2.3 The promise of solar photovoltaic(PV) water pumping

Solar Photovoltaic (PV) water pumping systems are a good solution to the problems, limits, and challenges of using diesel and electricity from the grid for water extraction and irrigation [2, 1, 9]. A solar PV water pumping system uses solar panels to convert sunlight into electricity using semiconductors. The motor pump is powered with the electricity generated by the solar panels when the solar PV system is designed appropriately, it can produce a compelling value proposition. Another big benefit of solar pumping is that they operate independently of supply chains for fuel. After the installation, no deliveries of Solar Power, no tank storage of fuel, and no trips to fill up a tank are necessary using this renewable form of energy: Sixty-three days of free Solar Power every month in every part of the world will be available to this remote, off-grid location, where poor access to the road inhibits effective transport.

Second, solar pumping systems have very low operating costs. Beyond the initial capital investment, the recurring expenses are minimal: occasional cleaning of the panel surfaces, periodic inspection of electrical connections, and eventual replacement of the pump motor or electronic components after many years of service. There are no fuel bills, no oil changes, and no engine rebuilds.

The third point regarding the use of solar pumping systems is that they will have an extremely low cost to operate over time. Other than the initial capital outlay to construct the system, the only other recurring costs for the ongoing operation of solar pumping systems are the occasional cleaning of solar panels, the periodic inspection of electrical components, and the eventual replacement of the pump or electrical components after several years of continual use. There are not any fuel

costs, oil change costs or rebuilding of engines costs for solar pumping systems.

The fourth point is that solar pumping systems create zero impact on the environment. When in operation, there are no GHG (greenhouse gases), there are no air pollutants and there are no noise pollutants generated from the use of solar pumping systems. Solar pumping systems do not use any water for cooling compared to a thermal power facility; therefore, the risk of water contamination from a fuel or oil spill will not occur. For communities committed to reducing their carbon footprint and meeting their climate targets, using solar pumping systems provides an ideal solution for decarbonising their agricultural water industry.

The fifth point is that solar pumping systems can be easily scaled or expanded upon to meet the needs of the end-users. A small scale solar pumping system using one or two solar panels can supply enough electricity to operate an individual household or a small garden, while a large scale solar pumping system using multiple (e.g., one dozen or more) solar panels can provide enough electricity to operate submersible pumps in deep wells or surface pumps used to irrigate large numbers of acres for multiple communities.

2.4 Technical challenges & the need for system-level advancements

Despite the clear benefits of using a PV panel to directly power a pumping system (called direct-coupled systems), the process can be inefficient and [9]. The previous discussion demonstrates how much a PV's output changes based on the solar irradiance levels (time of year, time of day, cloud cover, etc.) and temperature (a hot PV will output a lower voltage than a cold PV). These solar energy output fluctuations will cause the pump motor to run at a variable speed and generally at a lower power level than its design level which can lead to reduced water delivery to customers,

pump stalling, and premature wear on the pump. The inconsistency in solar output will create a system that delivers a small amount of water to a customer at 8am, a large amount of water to a customer at noon, and no water to a customer at 4pm when the sun is still shining on the PV.

To overcome the disadvantages of direct-coupling PV with water pumping systems and take advantage of the full potential of solar-powered water pumping, there must be a coordinated effort to advance system performance through a set of coordinated system-level improvements [8]. This literature review presents the results of existing research across four primary technological areas.

Solar Water Pumping Technologies are the basic components including PV panel types (Mono crystalline, Poly crystalline, and Thin Film), motor types (DC brushed, DC Brushless [10], AC Induction [11], and Synchronous Reluctance), and pump types (Centrifugal, Positive displacement, Submersible, and Surface mounted). The research in this field involves study of matching components for maximum output and performance under varying solar conditions.

DC-to-DC Boost Converter: A power electronics circuitry that converts the variable, low voltage output of a PV array to a consistent higher voltage for use in powering a pump motor. The boost converter also provides essential function of impedance matching between PV source and motor load. Key research areas include converter topology (classic boost, interleaved boost, SEPIC, Cuk), component selection (inductor, capacitor, MOSFET, diode), efficiency optimisation, and thermal management.

MPPT (Maximum Power Point Tracking) control algorithms that continuously adjust the operating point (by modulating the duty cycle of the boost converter) of the PV array to obtain the maximum available power, regardless of the

8 combination of irradiance and temperature. The intent of this review is to explore the most widely studied algorithms (e.g., Perturb & Observe [P&O], Incremental Conductance [INC], Fuzzy Logic Control [FLC], Artificial Neural Network [ANN], and newer, meta-heuristics [e.g. particle swarm optimisation]) with consideration given to their performance specific to water pumping applications [12] (i.e., rapid irradiance shifts and pump start-torque requirements).

2.5 Purpose of Literature Review

The purpose of this literature review is to combine previously stated knowledge in four different fields, solar pumping technologies, DC-DC boost converters, maximum power point tracking algorithms (MPPT), and PLC-based automation. In doing so, this review hopes to achieve the following:

- (i) To provide a summary of the state-of-the-art solutions in each of the four subject areas.
- (ii) To determine the advancements needed within each subject area in order to provide both a reliable, low-cost source of solar-powered water for agriculture and rural communities.
- (iii) To demonstrate how these technologies work together and are interrelated to one another at the system level.
- (iv) To present potential future research areas of study, including but not limited to, improved control strategy development; predictive maintenance; battery or water storage integration with solar pumping systems to create a virtual battery; and hybrid power systems that combine solar, wind and/or traditional generator back up.
- (v) The information within this literature review should serve as a resource for all researchers, professional engineers, development practitioners and policy

makers who are working towards achieving equitable access to sustainable water resources for all.

CHAPTER 3

STATE OF THE ART APPROACHES

3.1 Highly advanced DC-DC Converter circuits & H/W for Solar water pumping

Need for Advancing the DC-DC Boost Converter Circuits

In a solar water pumping system using photovoltaic cells, the DC-DC boost converter is responsible for connecting between the PV array that generates a highly varying voltage level and the motor drive or motor for pumping water that needs a high and constant voltage level to run efficiently. Although a simple classical single-stage boost converter circuit comprising only one inductor, one switching transistor, one diode, and one output capacitor is easy to design and build and very cheap, it is limited in its application when used for high-power solar pumping applications. This is because, in order to boost a voltage input level by a large factor (say from 30V to 300V), a classical single-stage boost converter needs to operate under very high duty cycles ($D > 0.9$). High duty cycle operation will bring many drawbacks such as the importance of diode reverse recovery time, high peak currents in the switch, high EMI levels, low efficiency, lack of controllability, high output voltage ripple and input current ripple, which is not preferred in a PV source for MPPT.

3.1.1 High-Gain, Interleaved, & Multilevel Boost Topologies

This class of converters is specifically tailored to obtain significant gain factors in terms of output/input ratio while avoiding the undesirable extremely high duty cycles of a regular boost converter. This is achieved by employing several energy storage devices such as inductors and capacitors or several switching cells acting either sequentially or cooperatively.

Interleaved Boost Converters

Interleaved boost converters feature two or more boost converter circuits working in parallel on the input/output sides, but with the switching actions shifted in phase relative to each other. As an example, in the two-phase interleaved boost converters there are two inductors and two switches; the first switch is turned on during certain duty cycles, while the second works with exactly the same duty cycle but shifted in time by 180 degrees, or, for an N-phase interleaved boost circuit, by $360/N$ degrees. Key advantages for solar pumping:

- **Lower Input Current Ripple:** As a consequence of the phase separation, the ripple portions of the currents flowing through the inductors cancel each other out. The net effect is a much more steady input current that the control circuit draws from the PV panel. Steadier current means fewer disturbances around the maximum point, thus making MPPT more efficient and ensuring optimal pumping performance.
- **Low Output Voltage Ripple:** Similarly, the pulses applied to the output capacitor occur at different times and therefore generate less ripple. It means reduced electrical load on the motor as well as improved torque delivery.
- **Better Thermal Design:** As there are several phases operating in parallel, the input current is split between two or more transistors and inductors. Each

device conducts less than half of the input power, reducing conduction losses and heat generation. Consequently, smaller and thinner heatsinks can be used.

- **High Effective Switching Frequency Without Switching Losses:** Although each individual switch functions at the base frequency (say, 50 kHz), the resulting combination frequency at both input and output ends will be N times the base frequency (say, 100 kHz for two phases). The benefit here is that we can reduce input and output filters' sizes without bearing the switching losses associated with operating the switch at 100 kHz.
- **Fault Tolerance:** Another advantage is fault tolerance where a phase failure can cause a system degradation. Such degradation may be useful when deployed in remote agricultural regions where maintenance may not be feasible immediately after the failure.

Multi-cell and Multi-stage Configurations: Not limiting ourselves to interleaved circuits, there are other multi-cell and multi-stage configurations such as the quadratic boost converter which uses two cascaded boost stages but employs only one switch. Another type is the coupled-inductor boost converter, which employs a coupled inductor to obtain a voltage gain using transformer action alongside boost voltage gain. Using a coupled inductor, a very high voltage gain (say 10:1 or higher) can be achieved even with lower duty ratios (say 0.6–0.7).

Multilevel Boost Converters

Multi-Level Converters produce a stepped output voltage of a number of discrete voltages, as opposed to a two-step ($0 - V_{out}$) voltage pulse train. Types of multi-level converters include the neutral point clamped (diode clamped), flying capacitor, and cascaded H-bridge topology. Using the technique in the boost converter frontend offers many advantages:

Reduction of the Voltage Across the Semiconductors: In multi-level

boost converter, the output voltage is divided among various switches or capacitors connected in series. Each switch must block a lesser voltage compared to that of a non-multilevel output voltage of the same magnitude. Lower voltage semiconductors have low on resistance ($R_{ds(on)}$), and thus low gate charge (Q_g). Reduced conduction and switching losses results.

Higher Quality of the Output Voltage: The output voltage is closer to an AC voltage, making it possible for a lesser filter to be used for filtering purposes.

Reduced Electromagnetic Interference: Since the output voltage varies from one level to another by relatively smaller increments (for example, from 100V to 200V as opposed to from 0V to 400V), then dv/dt is small hence less EMI production.

3.1.2 Soft-Switching & Resonant Techniques

In case of using the standard (or hard-switched) DC-to-DC converter, turning on and off the power switch takes place with the voltage and current present on the switch terminals. This leads to the appearance of switching losses: namely, turn-on losses (with falling voltage and rising current), and turn-off losses (rising voltage and falling current). These switching losses are tolerable at low switching frequencies, e.g., ranging from 20 to 50 kHz. However, in order to minimize the size of the reactor and capacitor, which have inverse proportionality to the switching frequency, the design engineer prefers high-frequency switching, e.g., reaching up to 100 kHz or higher.

Soft-switching techniques solve this problem by ensuring that the transistor switches at moments when either the voltage across it (Zero Voltage Switching, ZVS) or the current through it (Zero Current Switching, ZCS) is zero—ideally

both. By eliminating the overlap between voltage and current during transitions, soft-switching dramatically reduces switching losses, allowing efficient operation at much higher frequencies.

12 Zero Voltage Switching (ZVS) And Zero Current Switching (ZCS)

ZVS (Zero Voltage Switching): The switch turns ON with zero voltages at its drain-source ends (almost). Thus, there is no turn-on loss caused due to discharge of the output capacitance (C_{oss}) of the switch and thus no voltage-current overlapping occurs. ZVS is accomplished with help of resonant inductor-capacitor combination, which results in oscillations. With each oscillation, voltage is brought down to zero before a new switching cycle starts. Most of the resonant and quasi-resonant converters make use of ZVS technique.

ZCS (Zero Current Switching): The switch is turned off when the current flowing through it is zero. Thus, there is no switching loss and less reverse recovery loss from diode since diode charge will have time to recombine.

Resonant And Edge-Resonant Approaches

In resonant converters, there is a resonant tank circuit made up of inductor and capacitors (an LC filter), which produces sinusoidal voltages and currents on purpose. These switching transistors are switched on and off based on the zero crossings of these voltages (for ZVS) or currents (ZCS). Popular types of resonant converters are SRC, PRC, and LLC (uses two inductors and one capacitor; performs well under a broad range of input voltages – ideal for PV applications since the input voltage changes greatly due to irradiance and temperature).

The edge-resonant technique is a bit less extreme than the resonant method described above. It involves making some adjustments to the standard PWM boost

converter, including adding an additional inductor and capacitor, forming a resonance network that acts only when the switches are turned on and off. For most of the time, the circuit will behave exactly the same way as the conventional PWM converter. However, in the switching transitions, the resonant parts will come into play to produce zero-voltage or zero-current switching conditions.

Relationship with Solar Water Pumping Applications:

Recent studies in journals have been undertaken on using soft switching boost converters for pumping water through photovoltaic energy sources. According to their results,

There is potential to improve the efficiency of the boost converter from the standard level of 92–94% (typical of the hard switching system) to levels of 96–98% or even more.

Improved efficiency means less heat dissipation, especially in situations where temperatures may reach 40 degrees centigrade or above outdoors. It will contribute towards increased life cycles of electrolytic capacitors and semiconductors' junctions.

Soft switching systems can be operated at a higher frequency, for example, 200 kilohertz rather than 50 kilohertz. In other words, there will be potential to utilize smaller, lighter, and economical inductors, transformers, and capacitors.

There is less generation of electromagnetic interference (EMI), thus compliance with regulations and avoidance of interference between MPPT sensors [10] and PLC lines of communication.

Employment of semiconductor materials other than silicon MOSFETs, including silicon carbide or gallium nitride, has further improved the benefits of soft switching as discussed below.

3.1.3 Wide Bandgap Devices: SiC & GaN

Silicon (Si) has been used historically as the semiconductor material of choice in electronic applications. Silicon has reached its limit of physical limitations like the width of the bandgap (1.1eV), electric field (0.3MV/cm) at breakdown, and junction temperature of 150°C – 175°C. Some examples of wide-bandgap semiconductors which have an edge on silicon are silicon carbide (SiC, band gap of 3.3eV) and gallium nitride (GaN, band gap of 3.4eV).

Advantages Of SiC AND GaN Over Silico

Blocking High Voltage for Same Device Size: Due to its very high electric field (5–10x) compared to silicon, the silicon carbide and gallium nitride devices having similar physical dimensions as silicon will block 5–10 times the voltage.

On-Resistance Multiplied by Area ($R_{ds(on)} \times \text{Area}$): Very high electric field and electron mobility will result to extremely low resistance of the small silicon carbide and gallium nitride device.

Faster Switching Rates: Switching times of these devices is several orders of magnitude smaller compared to silicon components – in the order of picoseconds to nanoseconds.

Greater Tolerance to Higher Temperatures: The maximum allowable operating temperature in case of SiC devices is 200°C, 250°C or above (as opposed to 150–175°C for Si devices).

Lower Reverse Recovery Charge (Q_{rr}): For MOSFETs, the internal body diode has drastically lower reverse recovery charge in SiC devices than in Si devices.

Low Q_{rr} means less energy lost during the reverse recovery process and less EMI.

Practical Implications Of Solar Pump Converters

Replacing conventional MOSFET transistors made of silicon in a boost converter with components based on SiC and GaN leads to significant improvements at every stage:

- **Higher Efficiency:** A solar water pumping system utilizing a boost converter based on SiC technology can deliver a maximum efficiency of 98% – 99%, whereas one with a silicon boost converter operates at a level of 92% to 95%. A 5% gain in efficiency implies that a 2 kW pump operated for 6 hours daily would generate an extra 600 watt-hours or enough additional energy to pump extra hundred liters of water per day.
- **Lighter and Smaller Units:** Higher switching speeds (from 50 kHz to 500 kHz) reduce magnetics' sizes in relation to the capacity. A converter based on SiC technology can be built in a much smaller and lighter case.
- **Less Heat Dissipation Needed:** With lower conductive losses and switching losses, there will be less heat to dissipate. A Silicon Carbide-based converter will be able to work with just passive cooling (simple fins for a heat sink) even when a silicone-based converter requires active cooling such as a fan.
- **Better Functioning in PV Conditions:** PV cells produce electricity in a very wide voltage range (from, let's say, 20V on a cloudy day to 60V under peak sunlight). Wide band-gap based converters perform equally well regardless of whether the input voltage is at minimum values.

SiC VS. GaN: Complementary Strengths

Though SiC and GaN are wide bandgap materials, they differ in many ways and possess their own strengths:

- **Silicon carbide (SiC)** excels in applications involving high voltage (more than 600V, 1700V and above) and high temperatures. In case of handling big size solar pumping systems (10kW – 50kW) with high bus voltage, SiC would be better to be used.
- **Gallium Nitride (GaN)** excels in ultra fast switching speed (into MHz range) applications within the medium voltage range (up to 650V usually). GaN is ideal for small solar pumps (100W – 3 kW) where size is an important factor.

Modern pump drive systems have come to be designed from the ground up using wide bandgap devices. A high-efficiency solar pumping system would involve a front-end interleaved GaN boost converter working at 500 kHz followed by a GaN inverter powering a PMSM pump.

Table 3.1: Advanced Topologies and Technologies

Technology	Primary Benefit for Solar Pumping	Typical Efficiency Gain	Complexity Level
Interleaved Boost	Reduced ripple, better thermal distribution, higher effective frequency	+2-3%	Moderate
Coupled Inductor / Quadratic Boost	Very high voltage gain without extreme duty cycle	+3-5%	Moderate-High
Soft-Switching (ZVS/ZCS)	Reduced switching losses, enables higher frequency, smaller magnetics	+3-6%	High
SiC MOSFETs	High efficiency, high temperature operation, high voltage capability	+4-7%	Low-Moderate
GaN HEMTs	Extremely high frequency, compact size, very low switching losses	+5-8%	Moderate

3.2 Cutting-Edge MPPT Methods

3.2.1 The Constraints of Classical MPPT

Maximum Power Point Tracking (MPPT) forms the core of all efficient solar photovoltaic (PV) water pumping systems [12]. Classical MPPT algorithms like the

Perturb & Observe (P&O) [4, 7] and Incremental Conductance (INC) [6] have been used extensively in the solar industry for decades now. The advantages include their simplicity, ease of implementation on cheap controllers, and good performance in case of steady irradiance or very gradual variations.

But solar-based water pumping in reality is far from the ideal case scenario. Some of the constraints associated with classical algorithms include:

Fluctuations In Irradiance Level: Rapid fluctuations can be experienced due to cloud cover, tree or building shadows, early mornings and late evenings.

Partial Shading Condition (PSC): Under partial shading condition, the P-V curve will have many peaks with just one representing the global GMPP. A pumping system operated by the local peak will pump 30–50% less water.

Changes in Temperature: The variation in the MPP voltage is rather quick (-0.3% to $-0.5\%/^{\circ}\text{C}$) when it comes to crystalline silicon solar cells.

Water Pump as a Unique Type of Load: A water pump belongs to unique types of loads.

To address these limitations, researchers have developed a new generation of cutting-edge MPPT methods that go far beyond classical P&O and INC.

3.2.2 Hybrid & Adaptive MPPT Algorithms

The concept of the hybrid MPPT technique is straightforward; there is no single method that is the best under all circumstances.

INC + FUZZY LOGIC CONTROL (INC-FLC) HYBRID

The Incremental Conductance-based method acts as the main basis for decision making, while a fuzzy controller fine-tunes the MPPT perturbation step size.

Advantages for Solar Pumping System:

Fast Transient Response: In case an abrupt change in irradiance occurs due to passing clouds, the Fuzzy Controller increases the step size, enabling faster convergence to MPP by INC Algorithm.

Low Steady-State Oscillations: At steady-state when the system works close to MPP under constant sun, the Fuzzy Controller decreases the step size to its minimum possible.

Not Need for Expert Tuning (Once Designed): Though the rule base for Fuzzy Controller needs initial design, it operates independently without any adjustment necessary from the user.

Gain-Scheduled INC

An alternative method that is relatively simple yet equally effective is adaptive INC. In this variant, the step size varies according to a specified function of the operating conditions [13].

Computational Efficiency: The gain-scheduled control algorithm requires only a few extra lines of code beyond the conventional INC implementation.

Field-Tested Performance: Adaptive tuning has been thoroughly tested in real-world environments.

OTHER HYBRID COMBINATIONS

P&O-FLC: Like INC-FLC, but based on the P&O algorithm, with the fuzzy controller controlling the size and direction of perturbation.

INC-Neural Network (INC-NN): Here a neural network is used to learn (offline) the optimum voltage of the MPP from data obtained.

Fuzzy-Adaptive Duty Cycle: The fuzzy controller gives directly the duty cycle command to be used for the boost converter.

3.2.3 Meta-Heuristic & Machine Learning MPPT Methods

If partial shading exists on the PV module, then the generated P-V curve will have multiple peaks. Meta-heuristic optimization algorithms and machine learning algorithms are proposed for the GMPP problem.

Particle Swarm Optimization (PSO)

Particle Swarm Optimization is a type of algorithm that works on the concept of optimization problems by considering the social interaction among groups of birds and fish schools. After 10 to 20 iterations, the swarm achieves optimum voltage for maximum power output.

Advantages of PSO for Solar Pumping: Good Performance under Partial Shading Conditions. Simple Implementation. Parallelization is Possible.

Drawbacks: The initialization step (voltage scan) is required every time the system starts working.

Grey Wolf Optimization (GWO)

The Grey Wolf Optimizer (GWO) is an optimization technique which utilizes the hunting behavior and social structure of grey wolves in their packs [20].

Better Fast Convergence Rate than PSO: GWO has been seen to reach GMPP faster using less iterations (30–50%) compared to PSO.

Machine Learning Methods (Neural Networks And Lightweight Predictors)

Machine learning (ML) methods provide a completely new paradigm of the MPPT approach. An ML-based controller is trained beforehand on how to predict the MPP voltage.

Advantages: Incredibly Rapid Response. No Steady-State Oscillations. Natural Dealing With the Partial Shading Effect.

Disadvantages: Need for Training Set. Computational Needs. Generalization Issues.

Efficient Predictors: Some machine learning techniques require much less resources than the neural networks and include the decision tree-based approach, random forest algorithm, and k-Nearest Neighbor technique.

3.2.4 Fast & Robust Tracking in Dynamic Solar Pumping Applications

In a solar water pump, the only truly important measurement of system efficiency is daily water yield.

The Price To Pay For Slow Tracking

A classical fixed-step P&O algorithm might spend 5–10 perturbation cycles, or about 1–2 seconds, finding itself and starting to move towards the new MPP. When this happens 12 times per hour, the loss of energy can add up to 5–10% of the hourly maximum output [4, 7].

How Adaptive And Hybrid MPPT Minimizes Losses

Variable Step Size: Adaptive step sizes make it possible for the MPPT technique to perform big jumps.

Prediction of Power: Some sophisticated hybrid algorithms possess a module for predicting the power.

Feed Forward of Irradiance Information: An inexpensive auxiliary solar cell can be used to measure the current irradiation level.

Table 3.2: Review of Recent Comparative Studies

MPPT Method	Tracking Speed	Steady-State Oscillation	Partial Shading Handling	Compute Load	Suitability for Pumping
Classical P&O	Medium	High	Poor	Very Low	Fair (stable climates only)
Classical INC	Medium-Low	Medium	Poor	Low	Good (stable climates)
INC-FLC Hybrid	Fast	Very Low	Medium	Medium	Excellent (variable climates)
Adaptive Step INC	Fast	Low	Medium	Low	Excellent (cost-sensitive designs)
PSO	Medium (scanning delay)	Very Low	Excellent	Medium-High	Excellent (partial shading prevalent)
GWO	Fast (faster than PSO)	Very Low	Excellent	Medium	Excellent (partial shading prevalent)
NN-Based	Instantaneous	None	Excellent (if trained)	Medium-High (training) / Low (inference)	Excellent (high-end systems)

However, a 2023 study conducted by researchers at the National Institute of So-

lar Energy (simulated in a 5 kW pumping system) showed that an INC-FLC hybrid algorithm could improve daily water yield by 18–22% on a partly cloudy day and by 8–12% on a clear day compared to classical P&O algorithm. Additionally, the same study demonstrated that the use of the PSO-based GMPPT algorithm could provide recovery of 25–35% more water yield under partial shading.

Choice of Optimal MPPT Algorithm for Solar Pumping System:

For small-scale cost-efficient solar pump in consistently sunny areas with no shading issues: A classic INC method with adaptive gain tuning would be optimal.

In the case of systems operating in areas with frequently changing weather conditions or cloud coverage: A hybrid INC-FLC or adaptive step-based algorithm is highly recommended. The overhead costs are insignificant compared to the additional water yield of 15–25% daily.

3.3 Energy Buffering & Power-Management Strategies

3.3.1 The mismatch of Solar Energy Supply with pump hydraulic Or Electrical Power Demands

Solar photovoltaic driven water pumps have an intrinsic limitation, which is that the availability of solar energy (supply) seldom matches the hydraulic demand for water or the electricity demands of the pump motor. At early morning and late afternoon, solar irradiance levels are lower while the pump must start operation and supply some water for animal needs or other uses. During short-term cloud cover, PV arrays might reduce their production by 50–80% in few seconds, causing the pump to operate slower or even stop; during sunny periods, the solar energy production will be higher than what the motor can effectively use.

A simple way to cope with such mismatches consists in accepting them. Solar pumps run under sunny weather, cease operation during cloudy periods and provide

water flow rates in a very irregular manner. Although this solution works, it is obviously far from the optimal one. In recent years, scientists tried to overcome this problem by using two methods:

Use of transient smoothing techniques through the employment of either supercapacitors or battery packs for providing starting torque and enabling efficient pumping through pulsed technique.

Hybrid power supply systems utilizing multiple sources like solar PV and batteries, grid, or wind in combination with intelligent algorithms controlling the power supply for maximizing reliability.

Such techniques change a passive solar-powered pump into an active pumping system which is able to provide consistent water flow regardless of solar energy availability.

3.3.2 Supercapacitor Buffering & Pulsed Pumping

Using Supercapacitor Instead Of Batteries

Table 3.3: Comparison of Energy Buffering Technologies

Characteristic	Battery (Lead-Acid or Li-ion)	Supercapacitor
Energy density (Wh/kg)	High (30–250)	Low (1–10)
Power density (W/kg)	Low to medium (50–500)	Very high (5,000–20,000)
Charge/discharge efficiency	70–90%	95–99%
Cycle life	500–5,000 cycles	500,000 to 1,000,000 cycles
Charge time	Minutes to hours	Seconds to minutes
Temperature sensitivity	High (performance degrades outside 0–40°C)	Low (operates well from –40°C to +65°C)
Maintenance	Required (especially lead-acid)	Negligible

There are several notable advantages for the use of supercapacitors as a buffer solution for short-term energy storage in solar pumping applications including very long cycle life (up to 500,000 times), very high charge/discharge efficiency (95%–99%), very high power delivery capability, temperature tolerance, and maintenance free operation with no dangerous chemicals.

The biggest drawback of using supercapacitors is the relatively low level of their energy density. Hence, supercapacitors are better suited for buffering energy in seconds or minutes.

Handling Short-Term Energy Deficits AND Peaks

In a solar pumping system where there is a supercapacitor buffer, the supercapacitor bank is connected to the DC bus via a bidirectional DC-DC converter. According to recent studies published between 2023 and 2025, the installation of an appropriately sized supercapacitor storage (usually 50–100 farads of capacitance for each kilowatt of PV power) leads to 70–90 percent lower occurrence rate of stalls in a water pump. As a result, an increased volume of water is being pumped in a day: the figures range between 8–15%

Soft Start Capability

The use of a supercapacitor buffer enables the device to charge itself from the PV panels during the prestart period (such as 10–30 seconds of sunrise) and then release the stored energy as starting surge. It has been found from field studies that by using the supercapacitors, the minimum irradiance needed for pumping startup is reduced by 20–35%.

Pulsed Pumping Techniques

In addition to passive methods, the use of supercapacitors makes it possible to adopt a more advanced mode of the pumping system's operation called pulsing or bursting.

Pulsed Pumping Principle:

The Charging Phase (10–60 seconds): Solar panels charge the supercapacitor. The pump is not working.

The Pulse Phase (5–15 seconds): The pump starts functioning. Two power sources operate in tandem – photovoltaics and discharging supercapacitors.

The Rest Phase: Pumping stops. The supercapacitor starts charging.

Table 3.4: Experimental Results for Pumping Modes

Operating Mode	Daily Water Volume (liters)	Relative Gain vs. Continuous
Continuous (no buffer)	8,200 L	Baseline (100%)
Continuous with supercapacitor buffer (no pulsing)	9,100 L	+11%
Pulsed pumping (15s pulse / 45s charge)	11,500 L	+40%

3.3.3 Hybrid Systems (PV + BATTERY + Grid/Wind)

While supercapacitors excel at short-term buffering (seconds to minutes), they cannot store enough energy to bridge longer gaps. For these longer-duration challenges, hybrid systems that combine solar PV with other energy sources and larger-capacity storage are required.

A combination of PV and battery system would be capable of running a water pump for 14–16 hours per day. The addition of batteries significantly increases the capital cost of a solar pumping system (typically by 30–60% for a battery sized for 1 day of autonomy).

Table 3.5: PV-Battery System Sizing Considerations

Parameter	Typical Range	Notes
Battery capacity (energy)	0.5 to 3 days of average pumping energy	Smaller for cost-sensitive systems; larger for critical applications
Battery power rating	0.5 to 1.5× pump power	Must support pump starting surge
PV array oversizing	1.2 to 2.0× pump power	Oversized array provides excess energy for battery charging
Depth of discharge (DoD)	50–80% (lead-acid); 80–95% (Li-ion)	Deeper DoD yields more usable energy but reduces cycle life

Solar-Wind Profile Complementarity: Standard solar-wind profile complementarity will be as follows: The time at which peak generation of solar energy occurs: Midday, sunny period (summer for temperate zones, and dry season for tropical zones). The time when generation of peak wind energy takes place: Afternoon-evening hours, windy period (winter period, or just before monsoon period).

Complementarity allows generating electricity continuously. Architecture: PV Wind Hybrid Pump System has the following components: PV array + MPPT Controller; Wind turbine + Rectifier + MPPT controller for the wind turbine [15] (it should be noted that this controller is distinct from the MPPT controller of the PV array and it may contain tip-speed or power feedback control); DC Bus; Battery Array (because of wind energy variability being higher than solar energy variability); Bidirectional Battery Converter;

Table 3.6: Resource and System Comparison

Aspect	PV	Wind	PV+Wind Hybrid
Resource availability	Daytime only, good in dry season	Day/night, often better in windy season	Day/night, year-round
Variability	Predictable (diurnal + seasonal)	Highly unpredictable	Smoother combined output
Maintenance	Low (no moving parts)	High (moving parts, bearings, blades)	Medium
Space requirement	Large area (panels)	Tall tower + swept area	Both
Cost per watt (installed)	Low to medium	Medium to high (small scale)	High

3.3.4 Intelligent Energy Management System for Multiple Energies Sources

Since the energy comes from several sources (PV, battery, grid, wind etc.), there should be an EMS controller included into the system that would determine how to distribute energy among sources, when to recharge/discharge the storage system, and when the water delivery will be more important than saving energy. EMS objective Maximize the amount of delivered water during the planning period (for example, next 24 hours) Minimize the cost of operation of the energy system (minimal usage of fuels, electricity from grid and minimal degradation of battery) Increase battery life span by minimizing its dis/charging cycle Keep system availability by maintaining energy reserve for water delivery EMS control strategies Rule-based EMS control: Simple algorithm which utilizes threshold value rule, for example: "If

PV generation i pump power consumption and SOC i 90however non-optimal.

Table 3.7: Energy Buffering and Power-Management Strategies

Strategy	Timescale	Energy Capacity	Primary Benefit	Best Suited For	Relative Cost
Supercapacitor buffer	Seconds to minutes	Low	Cloud smoothing, soft start, pulsed pumping	Variable climates, positive displacement pumps	Low-Medium
Battery storage	Hours to days	Medium to High	Extended operating hours, weather resilience	High-reliability applications, off-grid	Medium-High
PV + grid hybrid	Continuous (grid available)	Unlimited (grid)	High reliability without large battery	Locations with unreliable grid	Medium
PV + wind hybrid	Continuous (complementary)	High	Year-round operation, seasonal complementarity	Windy sites with poor solar seasons	High
Intelligent EMS (MPC/RL)	Operational horizon	N/A	Optimal source scheduling, cost reduction	All multi-source systems	Low (software) to Medium (hardware)

3.4 Partial-Shading Mitigation & PV Array Management

3.4.1 The Destructive Effects of Partial Shading

Partial shading is among the most widespread and often underrated sources of inefficiency in photovoltaic water pumps. Partial shading can lead to disproportionately large reductions in energy output, often dropping the output power of the array by up to 50–70% even when only 10–20% of the panel surface is affected.

Table 3.8: Consequences of Shading Scenarios

Shading Scenario	Scenario	Array Fill Factor	Power Loss (Relative to No Shading)	Typical GMPP vs. LMPP Difference
No shading		1.0 (uniform)	0%	Single peak only
Single shaded cell (one panel)		0.7–0.8	20–30%	15–25% lower at LMPP
One shaded panel in a string of 10		0.5–0.6	40–50%	30–40% lower at LMPP
Multiple random shading patterns		0.3–0.5	50–70%	40–60% lower at LMPP

3.4.2 Current Mitigation Technologies for Partial Shade Problem

Three techniques are used: MLPE (Module Level Power Electronics), Reconfigurable Array Configurations, and Local MPPT for Each Sub-String.

3.4.3 Module Level Power Electronics (MLPE)

Module-Level Power Electronics (MLPE) is a set of technologies designed to be mounted on the individual panels (and in some cases sub-panels and cells). MLPE

devices used in solar pumping systems can either be a DC optimizer or a microinverter (but microinverter is mostly used in grid-connected system).

Table 3.9: Benefits of Module-Level Power Electronics

Benefit	Description	Quantified Impact
Elimination of mismatch losses	Each panel operates at its own MPP regardless of shading or degradation	15–40% power recovery under partial shading
Reduced temperature-related losses	Hot panels are not forced to match cold panels	3–8% gain on hot days
Flexible array layout	Panels can be installed in different orientations without mismatch	Enables morning/evening production
Panel-level monitoring	Identify underperforming panels for maintenance	Reduced downtime
Safety	Optimizers can reduce string voltage to safe levels during shutdown	Improved installer/maintenance safety

3.4.4 Micro Inverters for AC Pumping Systems

In solar pumping systems using an AC motor (which uses an inverter to change DC to AC power), micro inverters can provide an option to DC optimizers. A micro inverter is a compact, panel-mounted inverter that changes the DC power generated by one PV module into AC power. Several micro inverters are installed in parallel on the AC side. Relevance to Pumping: Micro inverters are primarily used in grid-connected residential photovoltaics; however, they are increasingly being utilized in off-grid solar pumps and water pumping schemes, especially in small systems (such as 500 W to 3 kW systems for pumping). In AC pumping systems, the same ad-

vantages provided by DC optimizers in partial shading compensation will be offered by micro inverters, while additionally removing the necessity for a centralized inverter. Off-grid micro inverters for pumping, however, have different requirements than their grid-connected counterparts.

Table 3.10: DC Optimizers vs. Microinverters for Pumping

Aspect	DC Optimizers + Central Pump Drive	Microinverters + AC Pump
Partial shading mitigation	Excellent (panel-level MPPT)	Excellent (panel-level MPPT)
System efficiency	High (98–99% per optimizer + 96–98% central drive)	Moderate (95–97% per microinverter)
Pump motor type	DC or AC (with central inverter)	AC only
Battery integration	Easier (DC coupling)	Harder (requires AC-coupled battery or rectifier)
Cost (per watt)	Low-medium	Medium-high
Complexity	Medium	High (many AC connections)
Best application	DC pumps, medium-large systems	Small AC pumps, systems with AC loads

3.4.5 Reconfigurable Array Topologies

Unlike the MLPE devices (DC optimizers), which are passive – optimizing each panel constantly without affecting the electrical connections within the array, reconfigurable array topologies are active systems employing arrays of electromechanical relays, solid-state switches (MOSFETs, IGBTs) or contactors for dynamic recon-

figuration of connection topology between PV panels depending on the shading conditions.

Dynamic Reconfiguration Concepts

A reconfigurable PV array normally comprises of a static number of panels (say, 4x4, 6x6, or 3x8 array) connected to a switching matrix capable of establishing various combinations of series/parallel connections between the panels. The control unit (microcontroller or PLC) [20] implements the following actions: Determine the I-V characteristics of each panel or groups of panels (by measuring at each panel or by sequential switching through the switching matrix); Assess the shading situation and find an optimal reconfiguration of connections (in terms of which panels will be connected in series, which in parallel, and which are better to bypass altogether); Physically establish the obtained configuration; Repeat the cycle if required.

Reconfigurable Array Topologies

Unlike the MLPE devices (DC optimizers), which are passive – optimizing each panel constantly without affecting the electrical connections within the array, reconfigurable array topologies are active systems employing arrays of electromechanical relays, solid-state switches (MOSFETs, IGBTs) or contactors for dynamic reconfiguration of connection topology between PV panels depending on the shading conditions.

Dynamic Reconfiguration Concepts

A reconfigurable PV array normally comprises of a static number of panels (say, 4x4, 6x6, or 3x8 array) connected to a switching matrix capable of establishing various combinations of series/parallel connections between the panels. The control unit microcontroller implements the following actions: Determine the I-V characteristics of each panel or groups of panels (by measuring at each panel or by sequential switch-

ing through the switching matrix); Assess the shading situation and find an optimal reconfiguration of connections (in terms of which panels will be connected in series, which in parallel, and which are better to bypass altogether); Physically establish the obtained configuration; Repeat the cycle if required. Irradiance-Equalizing (IE) Configuration:

The advanced technique is the irradiance balancing strategy in which the controller forms the groups in such a manner that the total irradiance (which determines the capacity of current) for all the series-connected panels is equalized. If there are any panels highly shaded, they are assigned together in the same series connected panels so that their reduced current capacity does not hinder the operation of other series strings and they can be reduced in number by using parallel connections to achieve balance in voltage. Optimal configuration for a reconfigurable panel can be obtained by solving a combinatorial optimization problem. If we consider a medium-sized reconfigurable panel, say 20 panels, then the possibilities of configurations will be in thousands. Following algorithms are used to achieve real-time solutions

Table 3.11: Optimization Algorithms for Reconfiguration

Algorithm	Description	Suitability for Pumping
Particle Swarm Optimization (PSO)	Population-based search; finds near-optimal configuration in 50–200 iterations	Good; well-studied for PV reconfiguration
Genetic Algorithm (GA)	Evolutionary algorithm using selection, crossover, mutation	Good but slower than PSO
Ant Colony Optimization (ACO)	Inspired by ant foraging behavior	Moderate; less common in PV reconfiguration
Artificial Neural Network (ANN)	Learns optimal configuration from training data; very fast in operation	Excellent (once trained) but requires offline training
Rule-based heuristics	Simple rules (e.g., “group shaded panels together”)	Fast but suboptimal for complex shading patterns

3.4.6 Local MPPT per Sub-String (Distributed MPPT)

Architecture And Working Principle

The architecture of DMPPT systems for solar water pumping involves the following elements: PV sub-strings: Several strings of 2-4 panels each connected in series but electrically isolated from each other.

Sub-string DC-DC converters: Often, buck-boost or SEPIC converters designed to work with a broad input voltage range necessary for MPPT and generating a uniform output voltage.

Common DC bus: The DC buses where sub-strings are connected are merged into

one (e.g., 350V DC) and delivered to the motor drive.

Controller: Coordinates the operation of sub-string converters (optional). **Operating Principle:** Each of the sub-string converters operates independently, using the MPPT method to follow the MPP regardless of whether the sub-string is under shadow or not. The fact that each sub-string contains only 2-4 panels reduces the likelihood of a complex multiple-peaked P-V curve occurring within a sub-string due to a shading pattern. In case any sub-string is affected by partial shading (i.e., some of its panels are partially shaded), the MPPT algorithm applied to the sub-string requires considering only the peaks due to the bypass diodes of the affected 2-4 panels rather than the 10-20 panels in a string. The output voltage of all sub-string converters is equal to the DC bus voltage. The currents of each of them are added to generate the required power to the pump drive.

Table 3.12: Comparison of MPPT Architectures

Architecture	Track	Shading Mitigation	Cost	Complexity	Eff (Uni-form)	Eff (Shaded)
Single MPPT (string)	1 per array	Poor	Low	Low	High (96–98%)	Low (40–60%)
Distributed MPPT	1 per 2–4 panels	Good	Medium	Medium	Medium (94–96%)	High (80–95%)
MLPE (Optimizer)	1 per panel	Excellent	High	High	Medium (92–95%)	Very High (95–98%)

3.4.7 COMPARATIVE ANALYSIS: Solar Water Pumping Vs. Electric Water Pumping

Initial Investment (Capital Cost):

The installation cost of the solar water pumping system will be quite higher than that of the electric pumps. Some of the initial costs include: Solar PV panels (mostly

expensive components) Fixings for solar PV panels MPPT controller/inverter Cabling and other installation equipment Installation labor charges The capital cost of the 3 HP system has been estimated at Rs. 2,92,250 (\approx \$3,500), while the cost of a 5 HP system is about Rs. 4,36,800. This very high initial cost is the most serious drawback of the solar water pumps, especially for the poor small farmers who have no access to finance. According to one Nigerian study, the cost of a solar water

Table 3.13: Initial Investment (Capital Cost)

Component	Solar Pump (3 HP)	Electric Pump (3 HP)
Primary power equipment	INR 1,40,000 (solar panels)	INR 30,000 (pump only)
Electrical connection	INR 0	INR 1,50,000
Inverter/controller	INR 20,000	INR 0
Mounting structure	INR 25,000	INR 0
Miscellaneous	INR 77,500	INR 0
Total Capital Cost	INR 2,92,250	INR 1,80,000

Life Cycle Cost (Total Cost Of Ownership):

The life cycle cost (LCC) analysis provides the most accurate comparison, accounting for capital costs, maintenance, replacements, and operational expenses over the system’s full lifespan.

Table 3.14: Documented Life Cycle Cost Comparison (25-year lifespan)

System Type	3 HP System LCC	5 HP System LCC
Solar PV Pumping	INR 3,51,286	INR 5,14,111
Electric (Grid) Pumping	INR 4,11,944	INR 5,49,115
Diesel Pumping	INR 6,97,177	INR 10,86,551

Table 3.15: Performance and Reliability Comparison

Performance Aspect	Solar Water Pump	Electric Water Pump
Power Consistency	Variable; depends on sunlight intensity	Constant; unaffected by weather
Daily Flow Rate	Peaks at noon; lower morning/evening	Consistent throughout operation
Night Operation	No (requires battery bank if needed)	Yes (24/7 capability)
Cloudy Weather	Reduced output (30–70% of normal)	Unaffected
Starting Torque	May struggle without soft-start/buffer	Full torque available immediately
Depth Capability	Good with appropriate sizing	Excellent for deep wells

Table 3.16: Summary Comparison Table

Criterion	Solar Water Pump	Electric Water Pump
Initial Capital Cost	High (INR 2.9–4.4 lakh for 3–5 HP)	Low to Medium (INR 1.8–1.9 lakh for 3–5 HP + grid connection)
Operating Cost	Zero (free sunlight)	Ongoing (INR 1.94–3.23 lakh lifetime)
Life Cycle Cost (25 yr)	Lowest (INR 3.51–5.14 lakh)	Medium (INR 4.11–5.49 lakh)
Maintenance	Low (panel cleaning)	Moderate (bearings, seals, electrical)
Grid Dependency	None (off-grid capable)	Complete (grid required)
Environmental Impact	Zero emissions	Grid-dependent
Lifespan (Panels/Pump)	25+ years / 8–12 years	5–10 years (pump)
Best Application	Remote, off-grid, day-time irrigation	Urban/suburban, 24/7 demand, deep wells

3.4.8 Working Principle Of Solar Water Pumping System

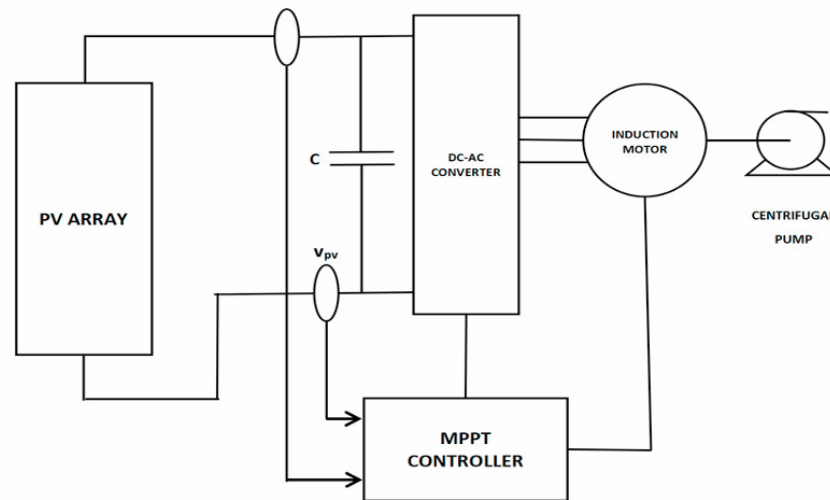

Fig. 2: Purposed Solar Water Pumping System

Figure 3.1: Purposed Solar Water Pumping System

Solar Energy Converter (PV Array Operation)

Irradiation energy is transformed into direct current electricity on the basis of the photovoltaic effect. Solar cell voltage varies from 0.5–0.6 Volts. Current increases linearly with respect to irradiation (W/m^2). Power increases nonlinearly ($P = V \times I$) dependent on irradiation and temperature. Standard values for panels' capacity: 250–600 W per panel, voltage open circuit: 24–50 V.

MPPT Control (Maximum Power Point Tracking)

Each PV unit has certain MPP (maximum power point), when $V \times I$ value reaches its maximum. Maximum power point (MPP): $dP/dV = 0$ (power vs voltage slope is zero). Energy generation was increased by 20–30% per day when compared with the directly coupled operation mode (or up to 40% with changing conditions). Without MPPT: pump functions during 6 hours per day. With MPPT: 8–9 hours per day.

DC–DC Boost Conversion

Most PV arrays produce relatively low voltage (e.g., 30–150 V DC). Many pumps require higher voltage (e.g., 300–600 V DC bus). A boost converter steps up voltage while stepping down current, preserving power (minus losses).

Voltage relationship (ideal):

$$V_{out} = \frac{V_{in}}{1 - D} \quad (3.1)$$

Where D = duty cycle ($0 < D < 1$). Example: $V_{in} = 100$ V, $D = 0.6 \rightarrow V_{out} = 100/0.4 = 250$ V. Efficiency typically 90–97% in modern MPPT boost converters.

Motor Drive Operation

Case A: DC Pump (Direct drive): Motor types: BLDC or PMDC [10, 14]. Boosted DC voltage directly powers the motor.

Case B: AC Pump (Common for >1 HP): Inverter converts boosted DC \rightarrow AC [11]. Pump affinity laws: Flow \propto Speed, Power \propto Speed³.

Pumping Water

Table 3.17: Pump types and applications

Pump type	Water source	Depth range	Typical use
Submersible pump	Borewell	10–150 m	Deep wells, high lift
Surface centrifugal pump	Tank, pond, river	< 7 m suction	Irrigation, transfer
Floating pump	Open well, pond	< 2 m suction	Low-lift, sediment-free
Diaphragm pump	Shallow well	< 15 m	Low flow, high head

Practical System Sizing Rule of Thumb:

- **Hydraulic power (W)** = Flow (LPS) × Total head (m) × 9.81 × 1000 [15]
- **Required PV power** = Hydraulic power / (Overall system efficiency)
- **Overall efficiency** typically 35–45% for AC systems, 45–55% for DC systems.
- **Example:** To pump 50,000 L/day (0.58 LPS) at 20 m head → Hydraulic power = 114 W → PV needed ≈ 300 W_p (for 5–6 sunlight hours).

Recent advances in solar water pumping systems (SWPS) have significantly improved their efficiency, reliability, and suitability for agricultural and rural water applications. Modern research focuses heavily on high-efficiency power-electronics, particularly the development of advanced DC–DC boost converters that offer higher voltage gain, lower switching losses, and improved stability under fluctuating solar conditions.

Wide-bandgap semiconductor devices such as SiC and GaN are increasingly incorporated to achieve higher switching frequencies and reduced thermal stress. Simultaneously, MPPT technology has progressed from conventional Perturb & Observe

and Incremental Conductance methods to hybrid and intelligent algorithms using fuzzy logic, neural networks, swarm optimization, and machine learning, enabling faster and more accurate tracking under variable irradiance and partial shading. In terms of motor-pump subsystems, research shows a strong shift toward Brushless DC (BLDC) [10, 14] and Permanent Magnet Synchronous Motors (PMSM) [16], which offer higher efficiency and better compatibility with variable-speed solar operation.

New studies also highlight the role of supercapacitor-assisted buffering, multiport converters, and intermittent pulse-based pump drives to enhance starting torque and improve water discharge during low sunlight periods without relying on large batteries. Furthermore, IoT-enabled remote monitoring and predictive maintenance solutions are being integrated to ensure long-term reliability and optimize water usage based on soil moisture, tank level, and weather forecasts.

Additional research is being conducted on system resilience to partial shading using module-level power electronics (MLPE) such as micro-inverters and DC optimizers. Lastly, sustainability and water-resource management studies now accompany technical innovations, focusing on preventing groundwater over-extraction and improving the socio-economic viability of large-scale solar pumping adoption. Together, these advancements represent a shift toward intelligent, efficient, and environmentally responsible solar water pumping solutions suitable for modern water-scarcity challenges.

CHAPTER 4

SIMULATION RESULTS AND DISCUSSION

4.1 Simulation Setup

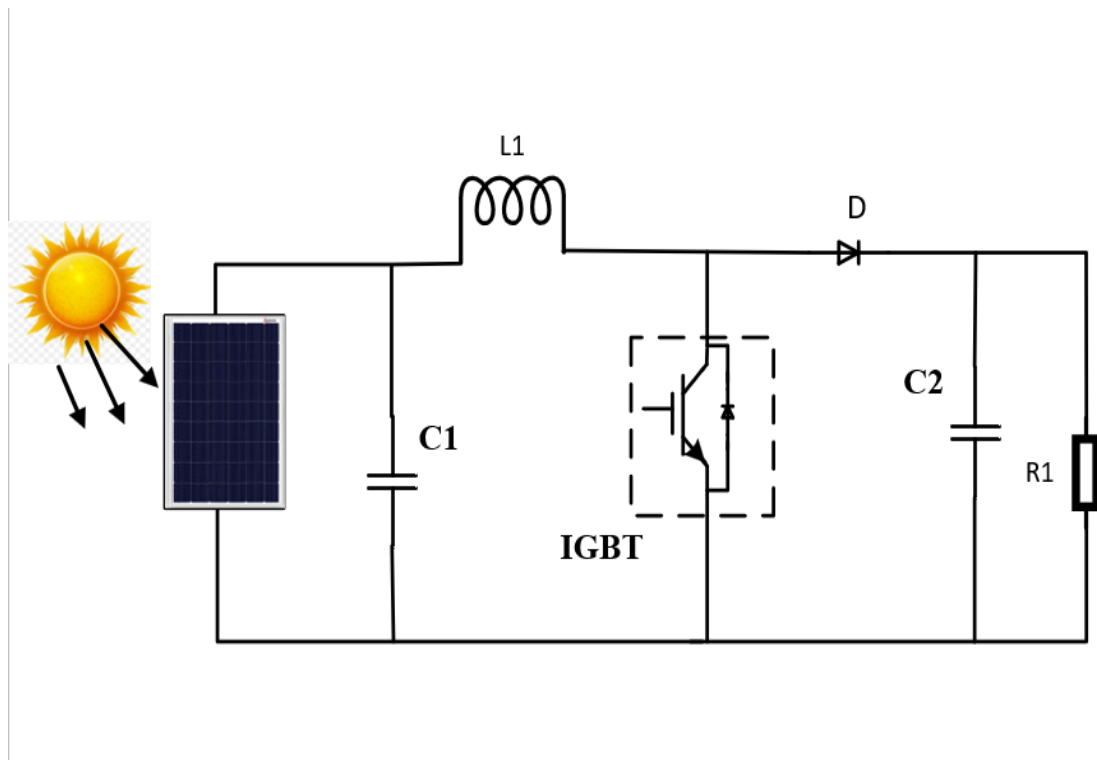

Figure 4.1: Block Diagram of the Solar Water Pumping System

The figure illustrates the MATLAB/Simulink simulation setup [17] of a solar water pumping system using a PV array and a DC–DC boost converter. The PV panel generates power under varying irradiance, while the Incremental Conductance (INC) MPPT algorithm controls the IGBT switch through PWM pulses. The converter boosts voltage efficiently to supply the load and improve system performance.

In this setup, the PV array acts as the primary energy source and converts solar energy into electrical energy. The irradiance input is provided through the repeating sequence block, which simulates changing sunlight conditions during operation. The generated PV voltage (V_{pv}) and current (I_{pv}) are continuously measured and supplied to the MPPT controller.

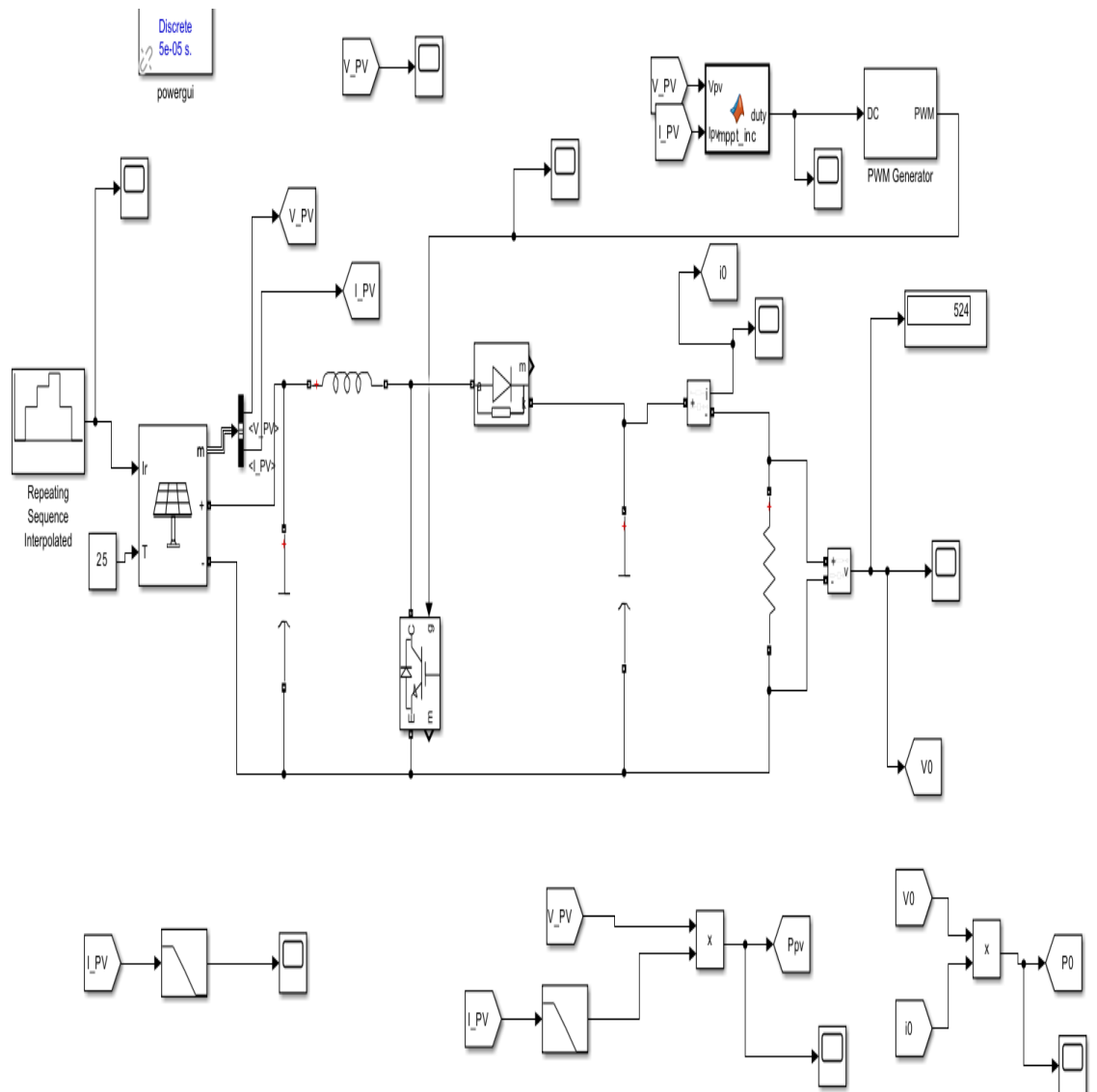

Figure 4.2: Simulation Setup of the Solar Water Pumping System

The simulation parameters for the PV array are summarized in Table 4.1.

Table 4.1: Block Parameter PV Array

Parameter	Value
Open ckt voltage Voc (V)	36.3
Short ckt current Isc (A)	7.84
Voltage at max point Vmp	29
Current at max point Imp (A)	7.35
Temp coff of Voc (%/deg.C)	-0.36099
Parallel	1
Series connected module per string	5
Max power (W)	213.15

Block parameters: Repeating sequence interpolated

Vector output values:

[0 0 500 800 800 1000 500 500 0 0]

Vector of time values:

[0 1.0 1.001 2.0 2.001 3.0 3.001 4.0 4.001 5.0 5.01 6.0]

RLC Values: Inductance = 76.8 mH, Capacitance = 400 μ F, Resistance = 300 Ω

4.2 Output Power Waveforms under Variable Irradiance

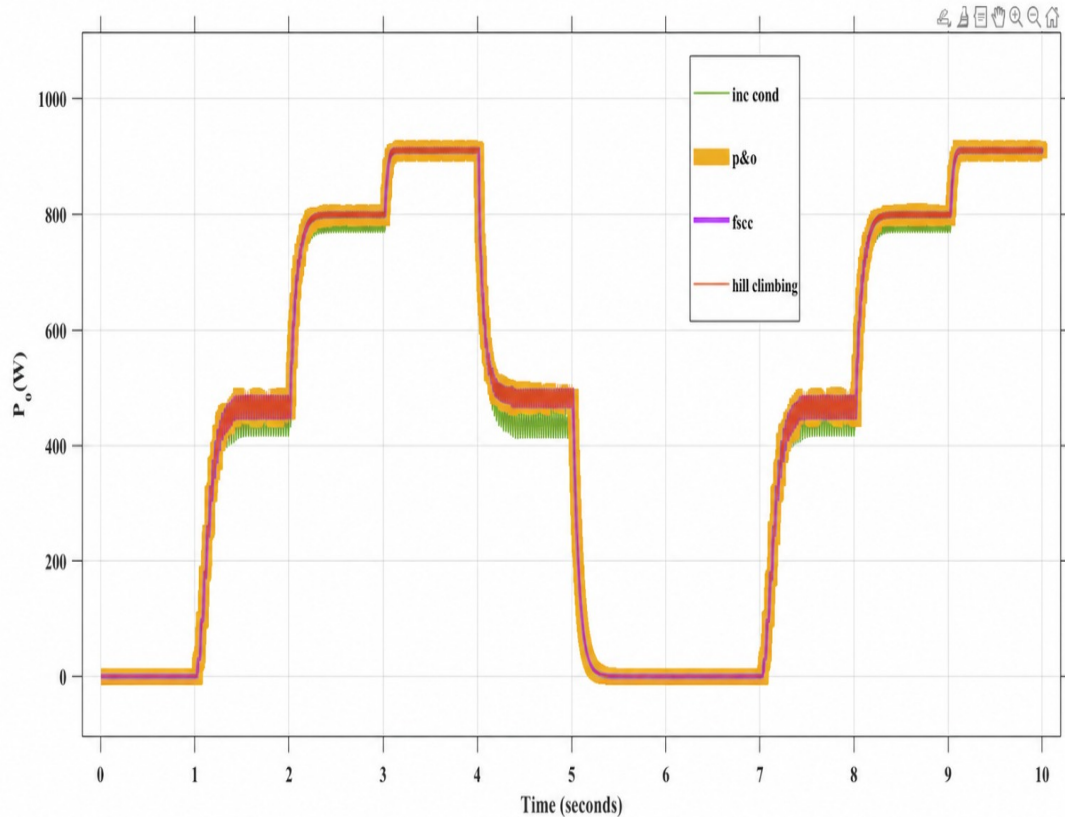

Figure 4.3: Output Power Waveforms under Variable Irradiance

4.2.1 Description of the Output Power (P_0) Waveform

The Fig 4.3 shows the output power response (P_0) of the solar PV system under different irradiance transitions over a 10-second simulation period. The four plots labelled Scope1, Scope2, Scope3, and Scope4 represent power outputs measured at different points (or different MPPT algorithms/variants), but all follow the same irradiance profile.

Irradiance Step-Up at $t \approx 1$ s

- The PV system initially produces almost zero power (low irradiance).
- At $t \approx 1$ s, irradiance increases sharply.

- Output power immediately rises and settles around 450–480 W.
- Small oscillations visible in Scope1 (green) represent MPPT tracking behavior.

Second Step-Up at $t \approx 2$ s

- Irradiance is further increased at ~ 2 seconds.
- P_0 increases smoothly and stabilizes around 780–820 W.
- All four scopes follow the same trend, showing consistent tracking.

Peak Irradiance at $t \approx 3$ s

- A final rise in irradiance pushes maximum power close to 900–950 W.
- The power settles quickly and maintains steady output.
- This confirms good dynamic performance of the converter and MPPT logic.

Irradiance Drop at $t \approx 4$ –5 s

- At around 4 seconds, irradiance decreases.
- P_0 drops from ~ 900 W to ~ 500 W.
- Settling time is short, indicating fast MPPT convergence.
- Scope1 shows slightly more ripple due to converter switching ripple.

Very Low Irradiance at $t \approx 5$ –7 s

- Irradiance drops close to zero.
- Output power also falls to near zero.
- MPPT algorithm correctly reduces duty cycle to prevent power oscillation.

Repeated Sequence at $t \approx 7-9$ s

- At $t \approx 7$ s, irradiance rises again, repeating the earlier trend:
 - Step to ~ 450 W
 - Step to ~ 800 W
 - Step to ~ 900 W
- The MPPT consistently tracks the maximum power point each time.

4.2.2 Key Observations

Fast MPPT response: Power settles quickly after each irradiance change.

Stable operation: All four scope traces overlap closely, showing stability across multiple measurement points.

Minor switching ripples: Visible mainly on Scope1 (green), typical of converter operation.

Accurate tracking: The system reaches correct power levels for each irradiance level.

4.3 High-Resolution View of Output Power Response

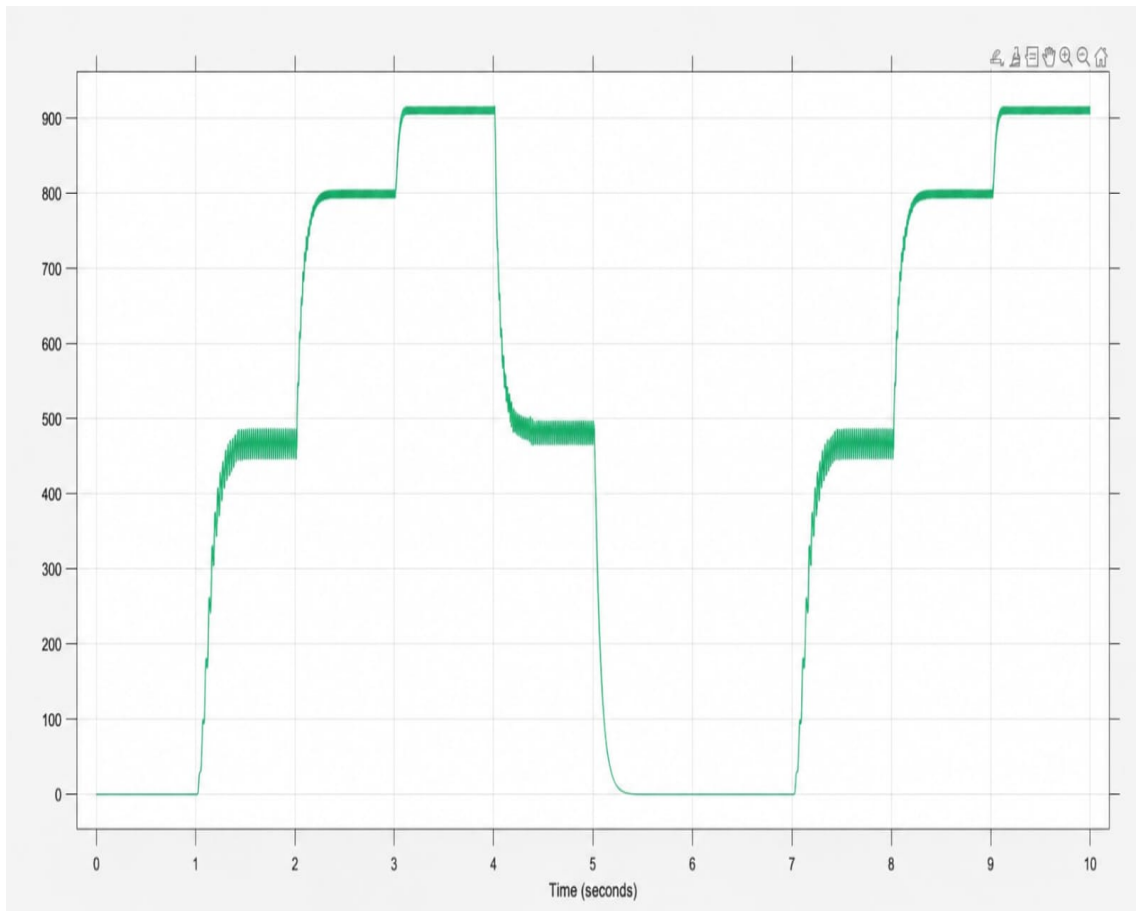

Figure 4.4: High-Resolution View of Output Power Response

4.3.1 Description of the Output Power Waveform

The plot represents the output power (P_0) of the solar PV system under a varying irradiance profile over a 10-second simulation. The waveform shows how the PV system behaves when the irradiance changes in step increments and decrements, and how effectively the MPPT algorithm tracks the maximum power point.

Initial Low-Irradiance Region (0–1 s)

- Output power remains near zero, indicating minimal sunlight.
- PV module does not produce usable power, and MPPT settles at a low duty cycle.

First Irradiance Step-Up (≈ 1 s \rightarrow 450 W region)

- At $t \approx 1$ s, irradiance increases suddenly.
- The output power rises sharply to about 450 W.
- Some high-frequency ripple is visible, caused by the boost converter switching and MPPT duty adjustments.

Second Irradiance Step-Up (≈ 2 s \rightarrow 780–800 W region)

- At $t \approx 2$ s, irradiance increases again.
- Output power climbs quickly and stabilizes around 780–800 W.
- Ripple remains controlled—indicating stable steady-state operation.

Third Irradiance Step-Up (≈ 3 s \rightarrow 900–920 W region)

- At around 3 s, irradiance reaches its peak.
- Output power rises to the 900–920 W level.
- Power remains steady with very small oscillations, showing accurate MPP tracking.

Irradiance Drop (≈ 4 –5 s)

- At 4 s, irradiance starts decreasing.
- Output power falls smoothly from the 900 W range down to 480–500 W.
- Ripple becomes slightly more noticeable in this mid-power region.

Very Low Irradiance Period (≈ 5 –7 s)

- At ≈ 5 s, irradiance falls almost to zero.
- Output power drops accordingly to nearly 0 W.

- MPPT correctly reduces the duty cycle to avoid oscillations.

Repeated Irradiance Steps (7–10 s)

The irradiance profile repeats its earlier pattern:

- Step from 0 W \rightarrow \sim 450 W at 7 s
- Step from 450 W \rightarrow \sim 800 W at 8 s
- Step from 800 W \rightarrow \sim 900 W at 9 s

The output power waveform follows the same rising and settling pattern as in the first cycle, confirming repeatable and stable MPPT behavior.

4.3.2 Key Observations

Fast Tracking Response: The system settles quickly after each irradiance change.

Stable MPPT Operation: Only small switching ripples appear—no oscillatory instability.

Accurate MPP Tracking: Power levels match expected PV output for each irradiance step.

4.4 MPPT Algorithm Used for Above Waveform

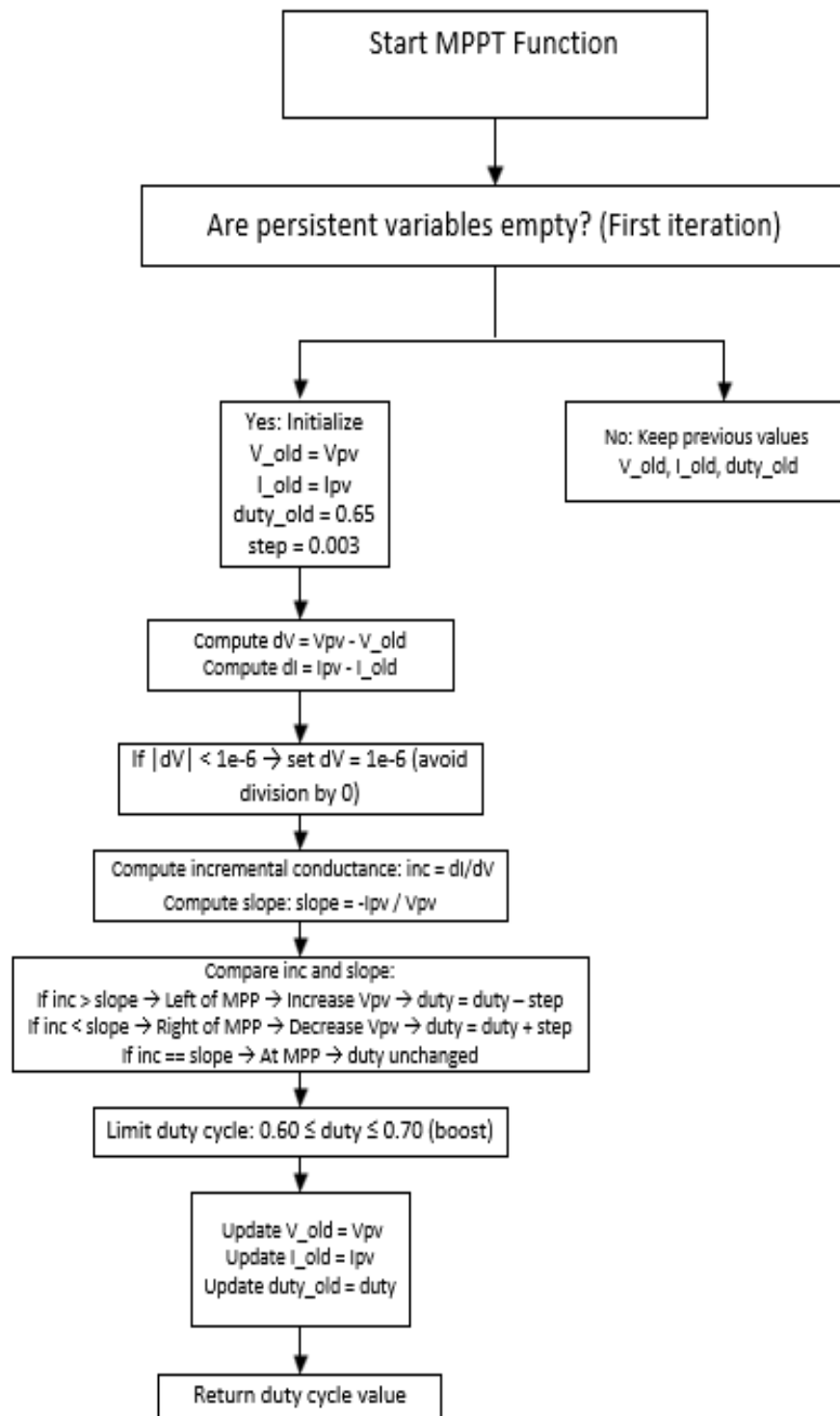

Figure 4.5: Flowchart of the Implemented Incremental Conductance Algorithm

The flowchart depicts the Incremental Conductance (INC) MPPT algorithm [6, 13] methodology for determining an optimal duty cycle for a boost converter in

photovoltaic (PV) systems to ensure maximum power extraction from the PV array. The algorithm begins by checking for the existence of the persistent variables, namely prior voltage and current measurements, previous duty cycle value, and the step size. If this is the first iteration, these persistent variables will be initialized to the current PV voltage and current measurements. Otherwise, they will retain their previously stored values. Then, the algorithm computes the change in voltage (ΔV) and change in current (ΔI) between the current and previous sample instants. To avoid an indeterminate result when calculating duty cycle slope ($\Delta V/\Delta I$), a small threshold will be applied to ΔV . The algorithm then computes:

- Incremental conductance: $\Delta I/\Delta V$
- Instantaneous conductance slope: $-I_{pv}/V_{pv}$

These two values are compared to determine whether the operating point is:

- Left of the Maximum Power Point (increase PV voltage \rightarrow decrease duty cycle),
- Right of the Maximum Power Point (decrease PV voltage \rightarrow increase duty cycle), or
- At the Maximum Power Point (no change in duty cycle).

The updated duty cycle is then limited between 0.60 and 0.70, which is the expected operating range for the boost converter.

CHAPTER 5

CONCLUSION

The waveforms show that the INC (Incremental Conductance) MPPT (Maximum Power Point Tracking) algorithm performed well in tracking the maximum power point of the photovoltaic (PV) system throughout the entire series of rapidly changing irradiance, with no oscillations occurring during the transition from one maximum power point to another. The dynamic response of the system was very fast, with a high degree of accuracy while at rest, and was consistent and repeatable, with similar tracking performance observed during several consecutive cycles occurring between approximately 7 seconds to 10 seconds. The amount of switching present during the mid-power levels was low compared to what would be expected to occur naturally when operating a boost converter and was therefore not a cause for concern regarding stability. In summary, the waveforms confirm that the INC MPPT Algorithm provides a stable, reliable, and efficient method[6, 13] by which to track and utilize the maximum amount of power produced by the PV array no matter what the environmental conditions may be.

5.1 Limitations of the Implemented INC MPPT System

There is an observable amount of ripple that will occur in the mid-power areas of the output power waveform that can be seen in the waveforms. There is a noticeable amount of switching ripple occurring near the 450–500 watt range of the output power waveform. This switching ripple indicates that the MPPT algorithm and

converter control algorithm have not been properly optimized for noise immunity and may therefore cause the MPPT system to experience degradation with respect to its ability to accurately track the maximum power point as it operates under varying conditions.

5.1.1 Fixed Duty Cycle Limits (0.60–0.70)

There are clearly observable fixed limits on the duty cycle due to the aliasing and design assumptions of the booster converter. While an important factor in maintaining the overall system stability; this limitation also prevents adaptability based on changes to either the load connected to the converter or any aspect of the photovoltaic panel being connected to the converter.

5.1.2 Noise Sensitivity in Measurements

The INC technique relies on accurate values of ΔV and ΔI . Voltage & current noise may cause error in slope detection, which can lead to oscillation in operation or slow convergence rates.

5.1.3 Slow Response Time for Instantaneous Change in Irradiance

As seen, the shape of the waveform exhibits some delay in stabilization during sudden decreases in irradiance (ex. - 4 - 5 seconds). This behavior is expected from INC techniques because they utilize data from the previous iteration of data, along with small step sizes.

References

- [1] G. Li *et al.*, “Research and current status of the solar photovoltaic water pumping system—A review,” *Renewable and Sustainable Energy Reviews*, vol. 79, pp. 440–458, 2017.
- [2] P. Periasamy, N. Jain, and I. Singh, “A review on development of photovoltaic water pumping system,” *Renewable and Sustainable Energy Reviews*, vol. 43, pp. 918–925, 2015.
- [3] M. Benzaouia *et al.*, “Design and performance analysis of a photovoltaic water pumping system based on DC-DC boost converter and BLDC motor,” in *2019 7th International Renewable and Sustainable Energy Conference (IRSEC)*. IEEE, 2019.
- [4] A. Sadick, “Maximum power point tracking simulation for photovoltaic systems using perturb and observe algorithm,” 2023.
- [5] T. Ramesh, “Solar powered based water pumping system using perturb and observation MPPT technique,” in *2018 IEEE International Students’ Conference on Electrical, Electronics and Computer Science (SCEECS)*. IEEE, 2018.
- [6] M. Elabbes and B. Brahim, “Modelling and control of photovoltaic system using the incremental conductance method for maximum power point tracking,” *Algerian Journal of Renewable Energy and Sustainable Development*, vol. 1, no. 2, pp. 191–197, 2019.

- [7] P. Manoharan *et al.*, “Improved perturb and observation maximum power point tracking technique for solar photovoltaic power generation systems,” *IEEE Systems Journal*, vol. 15, no. 2, pp. 3024–3035, 2020.
- [8] D. H. Muhsen, T. Khatib, and F. Nagi, “A review of photovoltaic water pumping system designing methods, control strategies and field performance,” *Renewable and Sustainable Energy Reviews*, vol. 68, pp. 70–86, 2017.
- [9] S. Chandel, M. N. Naik, and R. Chandel, “Review of performance studies of direct coupled photovoltaic water pumping systems and case study,” *Renewable and Sustainable Energy Reviews*, vol. 76, pp. 163–175, 2017.
- [10] R. Nisha and K. G. Sheela, “Review of PV fed water pumping systems using BLDC motor,” *Materials Today: Proceedings*, vol. 24, pp. 1874–1881, 2020.
- [11] B. Singh, U. Sharma, and S. Kumar, “Standalone photovoltaic water pumping system using induction motor drive with reduced sensors,” *IEEE Transactions on Industry Applications*, vol. 54, no. 4, pp. 3645–3655, 2018.
- [12] I. K. Abdul-Razzaq, M. M. F. Sakr, and Y. G. Rashid, “Comparison of PV panels MPPT techniques applied to solar water pumping system,” *Int. J. Power Electron. Drive Syst.*, vol. 12, no. 3, p. 1813, 2021.
- [13] G. Lorenzini, M. A. Kamarposhti, and A. A. A. Solyman, “Maximum power point tracking in the photovoltaic module using incremental conductance algorithm with variable step length,” *Journal Européen des Systèmes Automatisés*, vol. 54, no. 3, pp. 395–402, 2021.
- [14] R. Kumar and B. Singh, “Single stage solar PV fed brushless DC motor driven water pump,” *IEEE Journal of Emerging and Selected Topics in Power Electronics*, vol. 5, no. 3, pp. 1377–1385, 2017.
- [15] A. K. Tiwari and V. R. Kalamkar, “Effects of total head and solar radiation on the performance of solar water pumping system,” *Renewable Energy*, vol. 118, pp. 919–927, 2018.

- [16] B. Singh and S. Murshid, "A grid-interactive permanent-magnet synchronous motor-driven solar water-pumping system," *IEEE Transactions on Industry Applications*, vol. 54, no. 5, pp. 5549–5561, 2018.
- [17] S. Pant and R. Saini, "Solar water pumping system modelling and analysis using MATLAB/Simulink," in *2020 IEEE Students Conference on Engineering & Systems (SCES)*. IEEE, 2020.
- [18] S. Verma *et al.*, "Solar PV powered water pumping system—a review," *Materials Today: Proceedings*, vol. 46, pp. 5601–5606, 2021.
- [19] S. S. Kumar *et al.*, "Solar powered water pumping systems for irrigation: A comprehensive review on developments and prospects towards a green energy approach," *Materials Today: Proceedings*, vol. 33, pp. 303–307, 2020.
- [20] S. Hilarydoss, "Suitability, sizing, economics, environmental impacts and limitations of solar photovoltaic water pumping system for groundwater irrigation—a brief review," *Environmental Science and Pollution Research*, vol. 30, no. 28, pp. 71 491–71 510, 2023.
- [21] R. Sharma, S. Sharma, and S. Tiwari, "Design optimization of solar PV water pumping system," *Materials Today: Proceedings*, vol. 21, pp. 1673–1679, 2020.
- [22] A. Allouhi *et al.*, "PV water pumping systems for domestic uses in remote areas: Sizing process, simulation and economic evaluation," *Renewable Energy*, vol. 132, pp. 798–812, 2019.
- [23] O. V. Shepovalova, A. T. Belenov, and S. V. Chirkov, "Review of photovoltaic water pumping system research," *Energy Reports*, vol. 6, pp. 306–324, 2020.
- [24] K. Muralidhar and N. Rajasekar, "A review of various components of solar water-pumping system: Configuration, characteristics, and performance," *International Transactions on Electrical Energy Systems*, vol. 31, no. 9, p. e13002, 2021.

- [25] M. Errouha *et al.*, “High-performance standalone photovoltaic water pumping system using induction motor,” *International Journal of Photoenergy*, vol. 2020, pp. 1–13, 2020.
- [26] V. Ravindran *et al.*, “Simulated design and implementation of solar based water pumping system,” in *2021 2nd International Conference for Emerging Technology (INCET)*. IEEE, 2021.