

Vineet Tomar

Thesis - Updated.pdf

 Rashtriya Raksha University

Document Details

Submission ID

trn:oid::30110:141261161

Submission Date

Jun 1, 2026, 4:17 PM GMT+5:30

Download Date

Jun 1, 2026, 4:32 PM GMT+5:30

File Name

Thesis - Updated.pdf

File Size

1.2 MB

96 Pages

25,814 Words

146,721 Characters





10% Overall Similarity

The combined total of all matches, including overlapping sources, for each database.



Filtered from the Report

- ▶ Bibliography
- ▶ Small Matches (less than 10 words)

Match Groups

-  **150 Not Cited or Quoted** 9%
Matches with neither in-text citation nor quotation marks
-  **13 Missing Quotations** 1%
Matches that are still very similar to source material
-  **0 Missing Citation** 0%
Matches that have quotation marks, but no in-text citation
-  **0 Cited and Quoted** 0%
Matches with in-text citation present, but no quotation marks

Top Sources

- 5%  Internet sources
- 4%  Publications
- 8%  Submitted works (Student Papers)

Integrity Flags

0 Integrity Flags for Review

No suspicious text manipulations found.

Our system's algorithms look deeply at a document for any inconsistencies that would set it apart from a normal submission. If we notice something strange, we flag it for you to review.

A Flag is not necessarily an indicator of a problem. However, we'd recommend you focus your attention there for further review.

Match Groups

- 150 Not Cited or Quoted 9%**
Matches with neither in-text citation nor quotation marks
- 13 Missing Quotations 1%**
Matches that are still very similar to source material
- 0 Missing Citation 0%**
Matches that have quotation marks, but no in-text citation
- 0 Cited and Quoted 0%**
Matches with in-text citation present, but no quotation marks

Top Sources

- 5% Internet sources
- 4% Publications
- 8% Submitted works (Student Papers)

Top Sources

The sources with the highest number of matches within the submission. Overlapping sources will not be displayed.

1	Internet	dspace.dtu.ac.in:8080	1%
2	Internet	ajitelectricals.com	<1%
3	Submitted works	Hogeschool Inholland on 2026-05-19	<1%
4	Internet	www.dspace.dtu.ac.in:8080	<1%
5	Submitted works	University of Derby on 2025-05-11	<1%
6	Submitted works	University of Hertfordshire on 2026-04-27	<1%
7	Publication	S. Hiti, D. Borojevic. "Robust nonlinear control for boost converter", IEEE Transact...	<1%
8	Internet	www.mdpi.com	<1%
9	Internet	journal.esrgroups.org	<1%
10	Internet	www.coursehero.com	<1%

11	Submitted works	The University of the South Pacific on 2025-08-19	<1%
12	Internet	repository.iutoic-dhaka.edu	<1%
13	Internet	umpir.ump.edu.my	<1%
14	Submitted works	Anna University on 2025-02-14	<1%
15	Submitted works	Loughborough College on 2024-05-31	<1%
16	Internet	repository.mu.edu.et	<1%
17	Submitted works	Anna University on 2024-05-28	<1%
18	Submitted works	University of Teesside on 2026-04-28	<1%
19	Submitted works	Visvesvaraya Technological University on 2014-10-29	<1%
20	Submitted works	The University of Manchester on 2010-09-05	<1%
21	Submitted works	University of Bristol on 2023-04-27	<1%
22	Submitted works	University of Sydney on 2023-11-03	<1%
23	Publication	Lecture Notes in Electrical Engineering, 2015.	<1%
24	Submitted works	Technological University Dublin on 2026-04-19	<1%

25	Internet	ebin.pub	<1%
26	Internet	www.researchgate.net	<1%
27	Submitted works	Universiti Teknologi Malaysia on 2011-05-24	<1%
28	Submitted works	University of New South Wales on 2012-05-24	<1%
29	Submitted works	Coventry University on 2026-04-14	<1%
30	Publication	Raj Kapur Kumar, Paulson Samuel. "Efficient solar hydrogen generation using PE..."	<1%
31	Publication	"AI-Driven Solutions and Emerging Power Technologies for Sustainable Future", S...	<1%
32	Submitted works	Higher Education Commission Pakistan on 2010-11-03	<1%
33	Submitted works	Visvesvaraya Technological University on 2014-10-29	<1%
34	Internet	www.ijert.org	<1%
35	Submitted works	Liverpool John Moores University on 2026-04-26	<1%
36	Submitted works	Motilal Nehru National Institute of Technology on 2025-12-08	<1%
37	Submitted works	University of Edinburgh on 2020-04-22	<1%
38	Submitted works	Visvesvaraya Technological University on 2014-11-29	<1%

39	Internet	cupdf.com	<1%
40	Internet	vdocuments.mx	<1%
41	Submitted works	The Hong Kong Polytechnic University on 2010-11-26	<1%
42	Submitted works	The Scientific & Technological Research Council of Turkey (TUBITAK) on 2026-03-19	<1%
43	Publication	Thulasi V, Lakshmi P, SANGEETHA SIVAKUMAR. "DESIGN OF HYBRID OPTIMIZED P...	<1%
44	Publication	Zeynep Bala Duranay. "Output Voltage Regulated Sepic Converter for Photovoltaic...	<1%
45	Publication	"The Proceedings of the 19th Annual Conference of China Electrotechnical Societ...	<1%
46	Publication	Aimi Idzwan Tajudin, Mohammad Amirul Adika, Ahmad Asri Abd Samat, Saiful Fir...	<1%
47	Publication	Ambe Harrison, Njimboh Henry Alombah. "A New High-Performance Photovoltaic...	<1%
48	Submitted works	Frederick University on 2022-06-17	<1%
49	Submitted works	Heriot-Watt University on 2026-04-23	<1%
50	Submitted works	Jawaharlal Nehru Technological University on 2025-09-17	<1%
51	Submitted works	Malta College of Arts,Science and Technology on 2026-05-26	<1%
52	Publication	Mohammad Suhail Khan, Chang-Hua Lin, Javed Ahmad, Mohammad Fahad, Hwa-...	<1%

53	Submitted works	SASTRA University on 2015-10-07	<1%
54	Submitted works	Stanmore College on 2022-01-17	<1%
55	Submitted works	The Hong Kong Polytechnic University on 2006-05-03	<1%
56	Submitted works	The University of Manchester on 2010-09-06	<1%
57	Submitted works	Universiti Malaysia Perlis on 2011-07-02	<1%
58	Submitted works	University of Bradford on 2005-05-13	<1%
59	Submitted works	University of East London on 2015-11-30	<1%
60	Submitted works	University of Leeds on 2012-08-29	<1%
61	Submitted works	University of Newcastle upon Tyne on 2012-12-05	<1%
62	Submitted works	University of Nottingham on 2021-09-13	<1%
63	Submitted works	University of Technology on 2021-01-10	<1%
64	Publication	V. Sharmila, S. Kannadhasan, A. Rajiv Kannan, P. Sivakumar, V. Vennila. "Challeng...	<1%
65	Submitted works	Vaal University of Technology on 2023-11-03	<1%
66	Publication	W. M. Utomo, N. A. A. Isa, A. A. Bakar, A. F. H. A. Gani, B. E. Prasetyo, H. Elmunsyah...	<1%

67	Internet	dspace.unimap.edu.my	<1%
68	Submitted works	iGroup on 2014-11-07	<1%
69	Submitted works	iGroup on 2016-05-14	<1%
70	Internet	mobt3ath.com	<1%
71	Internet	repository.najah.edu	<1%
72	Internet	repository.up.ac.za	<1%
73	Publication	Duberney Murillo-Yarce, Javier Munoz, Carlos Restrepo. "Mamdani type PI-fuzzy c..."	<1%
74	Submitted works	Fakultet elektrotehnike i računarstva / Faculty of Electrical Engineering and Com...	<1%
75	Submitted works	Imperial College of Science, Technology and Medicine on 2012-12-14	<1%
76	Submitted works	K Ramakrishna College of Engineering on 2020-09-13	<1%
77	Publication	L. Schuch, C. Rech, H.L. Hey, J.R. Pinheiro. "Integrated ZVT Auxiliary Commutation ..."	<1%
78	Submitted works	Multimedia University on 2010-09-18	<1%
79	Submitted works	RMIT University on 2012-10-11	<1%
80	Publication	Raunak Karan, Saurabh Mishra, Mayank Kumar. "Small Signal Analysis of Non-Ide..."	<1%

81	Submitted works	Teesside University (Blackboard Ultra) on 2026-01-22	<1%
82	Publication	Yongjuan Zhao, Chaozhe Guo, Jiangyong Mi, Lijin Wang, Haidi Wang, Hailong Zha...	<1%
83	Internet	dokumen.pub	<1%
84	Internet	iaac.technion.ac.il	<1%
85	Internet	www.freepatentsonline.com	<1%
86	Internet	www.srmap.edu.in	<1%
87	Publication	"Electric Mobility and Hybrid Microgrid", Springer Science and Business Media LL...	<1%
88	Submitted works	Anna University on 2025-07-08	<1%
89	Publication	Badur M. Alharbi, Majid A. Alhomim, Roy A. McCann. "Robust Control for Cascade ...	<1%
90	Submitted works	Caledonian College of Engineering on 2009-04-28	<1%
91	Submitted works	Cardiff University on 2020-11-09	<1%
92	Submitted works	College of Engineering, Pune on 2020-09-15	<1%
93	Submitted works	Drexel University on 2007-09-22	<1%
94	Submitted works	Islamic University of Technology on 2024-12-31	<1%

95	Publication	Laksh mi, R., X. Felix Joseph, S. Pushakumar, and D. Arun Dominic. "Design simula...	<1%
96	Submitted works	Malta College of Arts,Science and Technology on 2026-05-29	<1%
97	Submitted works	Nanyang Technological University on 2024-05-03	<1%
98	Submitted works	SASTRA University on 2015-10-07	<1%
99	Submitted works	SSN COLLEGE OF ENGINEERING, Kalavakkam on 2026-03-08	<1%
100	Publication	Spandana Kolipaka, Kiran Teeparthi, Akhil Yadav Mudiminchi. "Robust Type-2 Fuz...	<1%
101	Submitted works	Taylor's Education Group on 2020-07-27	<1%
102	Submitted works	Teaching and Learning with Technology on 2026-03-30	<1%
103	Submitted works	UT, Dallas on 2007-11-21	<1%
104	Submitted works	Universiti Tun Hussein Onn Malaysia on 2026-04-28	<1%
105	Submitted works	University of Derby on 2026-05-01	<1%
106	Submitted works	University of Hertfordshire on 2025-06-23	<1%
107	Submitted works	University of Leeds on 2015-02-24	<1%
108	Submitted works	University of Newcastle upon Tyne on 2016-08-30	<1%

109	Submitted works	University of Newcastle upon Tyne on 2023-08-24	<1%
110	Submitted works	University of Nottingham on 2009-05-01	<1%
111	Submitted works	University of Nottingham on 2009-05-12	<1%
112	Submitted works	University of Nottingham on 2017-04-28	<1%
113	Submitted works	University of Portsmouth on 2023-05-12	<1%
114	Submitted works	University of Strathclyde on 2020-11-27	<1%
115	Submitted works	University of Strathclyde on 2024-04-07	<1%
116	Submitted works	University of Sydney on 2020-09-01	<1%
117	Submitted works	University of Teesside on 2024-01-05	<1%
118	Publication	V. Madhani. "Time-averaging equivalent circuit analysis and controller design of f..."	<1%
119	Submitted works	VIT University on 2014-04-29	<1%
120	Internet	eprints.utm.edu.my	<1%
121	Internet	ir.jkuat.ac.ke	<1%
122	Internet	mdpi-res.com	<1%

123	Internet	ojs.studiespublicacoes.com.br	<1%
124	Internet	researchinventy.com	<1%
125	Internet	www.hindawi.com	<1%
126	Internet	www.icsmartgrid.com	<1%
127	Internet	www.ijcic.org	<1%
128	Internet	www.jstage.jst.go.jp	<1%
129	Internet	www.slideshare.net	<1%

M. Tech (Control & Instrumentation)

Vineet Tomar

2026

**PERFORMANCE ANALYSIS OF BOOST CONVERTER
UNDER NONLINEAR SCENARIOS**

DISSERTATION/THESIS

**SUBMITTED IN PARTIAL FULFILLMENT OF THE REQUIREMENTS FOR
THE AWARD OF THE DEGREE
OF**

**MASTER OF TECHNOLOGY
IN**

CONTROL & INSTRUMENTATION

Submitted by:

VINEET TOMAR

(2K24/C&I/13)

Under the Supervision of

DR. DHEERAJ JOSHI

(Professor, EED, DTU)



**DEPARTMENT OF ELECTRICAL ENGINEERING
DELHI TECHNOLOGICAL UNIVERSITY**

(Formerly Delhi College of Engineering)

Bawana Road, Delhi-110042

MAY, 2026

DEPARTMENT OF ELECTRICAL ENGINEERING
DELHI TECHNOLOGICAL UNIVERSITY

(Formerly Delhi College of Engineering)

Bawana Road, Delhi-110042

CANDIDATE'S DECLARATION

1 I, **Vineet Tomar**, Roll No. 2K24/C&I/13 student of M. Tech (Control & Instrumentation), hereby declare that the project Dissertation titled "**Performance Analysis of Boost Converter Under Nonlinear Scenarios**" which is submitted by me to the Department of Electrical Engineering Department, Delhi Technological University, Delhi in partial fulfillment of the requirement for the award of the degree of Master of Technology, is original and not copied from any source without proper citation. This work has not previously submitted for the award of any Degree, Diploma.

1

DEPARTMENT OF ELECTRICAL ENGINEERING
DELHI TECHNOLOGICAL UNIVERSITY

(Formerly Delhi College of Engineering)

Bawana Road, Delhi-110042

CERTIFICATE

1

I hereby certify that the project Dissertation titled “**Performance Analysis of Boost Converter Under Nonlinear Scenarios**” which is submitted by Vineet Tomar, Roll No. 2K24/C&I/13, Department of Electrical Engineering, Delhi Technological University, Delhi in partial fulfilment of the requirement for the award of the degree of Master of Technology, is a record of the project work carried out by the student under my supervision. To the best of my knowledge this work has not been submitted in part or full for any Degree or Diploma to this University or elsewhere.

Place: Delhi

Date: 31.05.2026

Dr. Dheeraj Joshi

(SUPERVISOR)

DEPARTMENT OF ELECTRICAL ENGINEERING DELHI TECHNOLOGICAL UNIVERSITY

(Formerly Delhi College of Engineering)

Bawana Road, Delhi-110042

ACKNOWLEDGEMENT

I would like to express my gratitude towards all the people who have contributed their precious time and effort to help me without whom it would not have been possible for me to understand and complete the project.

I would like to thank **Dr. Dheeraj Joshi** (Professor, Department of Electrical Engineering, DTU, Delhi) my Project guide, for supporting, motivating and encouraging me throughout the period of this work was carried out. His readiness for consultation at all times, his educative comments, his concern and assistance even with practical things have been invaluable. I would also like to thank the Power Electronics Laboratory, Delhi Technological University for providing necessary facilities for performing my research work.

Finally, I must express my very profound gratitude to my parents, seniors and to my friends for providing me with unfailing support and continuous encouragement throughout the research work.

Date: 31.05.2026

Vineet Tomar

M. Tech (Control & Instrumentation)

Roll No. 2K24/C&I/13

ABSTRACT

The project based on a closed loop PI controlled boost converter using the following two nonlinear operating points: saturation nonlinearity and dead-zone nonlinearity. Boost converter is much applied in power electronic applications to increase the voltage of low DC source to a higher voltage which is much regulated. While the theory is applicable, practical converter systems are subject to nonlinear behaviors and limitations in control which can act differently in overall performances and stability. This work, therefore, is based on the study of the effect such nonlinearities have on the dynamic response of a boost converter with a PI controller. The proposed system is based upon the use of a Proportional–Integral (PI) controller in a closed-loop system to control output voltage of the boost converter. The error between the reference voltage and the actual voltage output is continuously monitored by the controller and fed to the switching device to adjust the duty cycle to reduce the error to a minimum. The proportional portion of the feedback circuit provides better transient response and the integral portion removes steady-state error and enhances voltage regulation. In idealized systems, the duty cycle may be controlled between preselected limits, but, in practical systems, two upper and lower limits must be established because of the limitations of switching devices and of hardware. If the controller output exceeds these bounds, saturation occurs that can influence converter response and stability. Another nonlinear effect that is necessary to consider is the phenomenon of dead-zone nonlinearity, in which small control signals are not enough to give any response from the system. The PI controller shows a stable operating condition of the converter even in the presence of nonlinearities as shown by the simulation results. The voltage regulation of the controller is satisfactory and the dynamic response is quick while the steady-state error is negligible under different operating conditions. Saturation and dead-zone nonlinearities of the converter are then compared and their effects on converter performance are understood. The study points to the fact that nonlinear effects need to be taken into account when designing a controller; and that the design's ability to deal with nonlinear effects in a power electronic system can be improved by using PI control techniques.

Keywords: Boost Converter, PI Controller, Closed-Loop Control, Saturation Nonlinearity, Dead-Zone Nonlinearity, MATLAB/Simulink.

TABLE OF CONTENTS

	CANDIDATE DECLARATION	ii
71	CERTIFICATE	iii
	ACKNOWLEDGEMENT	iv
10	ABSTRACT	v
	TABLE OF CONTENT	vi
	LIST OF TABLES & FIGURES	ix
	LIST OF ABBREVIATIONS	x
	LIST OF SYMBOLS	xi
	CHAPTER 1: INTRODUCTION	1
	1.1 Introduction	1
	1.2 Research Background	6
	1.3 Thesis Motivation	9
	1.4 Thesis Objectives	10
	1.5 Thesis Organization	10
17	CHAPTER 2: DESIGN AND ANALYSIS OF BOOST CONVERTER	13
	2.1 Introduction	13
1	2.2 Basic of Circuit Diagram of Boost Converter	14
	2.3 Working Principle of Boost Converter	14
14	2.4 Modes of Operation of Boost Converter	14
	2.4.1 Mode 1	15
	2.4.2 Mode 2	15
	2.5 Continuous Conduction Mode (CCM)	16
	2.6 Design of Boost Converter	17
	2.6.1 Duty Cycle Calculation	17
14	2.6.2 Inductor Design	18
	2.6.3 Capacitor Design	18
	2.6.4 Switching Frequency Selection	19
	2.7 Advantages & Limitations of Boost Converter	19
	2.8 Practical Application of Boost Converter	20
	2.9 Chapter Summary	20

	CHAPTER 3: MATHEMATICAL MODELLING OF BOOST CONVERTER	22
	3.1 Introduction	22
	3.2 Mathematical Modelling	23
	3.3 Derive a Small Signal Model of Boost Converter (CCM)	30
	3.4 Chapter Summary	32
68	CHAPTER 4: DESIGN OF PI CONTROLLER	33
	4.1 Introduction	33
	4.2 Design of PI Controller for Boost Converter	35
	4.3 Proportional Action	35
	4.4 Integral Action	36
	4.5 Combined Effect of PI Controller	37
	4.6 Calculating PI Values Using the Ziegler-Nichols Method	39
	4.7 Chapter Summary	42
	CHAPTER 5: NONLINEAR DYNAMICS	43
93	5.1 Introduction	43
	5.2 Nonlinearities of Boost Converter	44
	5.3 Saturation Dynamics	45
	5.4 Dead Zone Dynamics	46
	5.5 Chapter Summary	48
	CHAPTER 6: SIMULATION & PERFORMANCE ANALYSIS	50
	6.1 Introduction	50
	6.2 With Saturation Nonlinear Dynamics	51
	6.3 With Dead Zone Dynamics	60
	6.4 Chapter Summary	69
32	CHAPTER 7: CONCLUSION & FUTURE SCOPE	71
	7.1 Conclusion	71
	7.2 Future Scope	74

REFERENCES**77****LIST OF PUBLICATION****84**

LIST OF TABLE & FIGURES

	TABLE	
Table 2.1	Boost Converter Parameters	17
	FIGURES	
Fig 3.1	Boost Converter	24
Fig 3.2	First Mode of Operation (Switch ON, Diode OFF)	24
Fig 3.3	Second Mode of Operation (Switch OFF, Diode ON)	27
Fig 6.1	Block Diagram Representation	52
Fig. 6.2	Circuit/Block representation of closed-loop PI control of a Boost converter with Nonlinear saturation dynamics	54
Fig. 6.3	Ouput of Saturation Dynamics	56
Fig. 6.4	Input Current (Input Inductor current)	57
Fig. 6.5	Output Voltage (Volts)	60
Fig. 6.6	Block diagram representation	61
Fig. 6.7	Circuit/Block representation of closed-loop PI control of a Boost converter with Nonlinear Dead Zone dynamics	62
Fig. 6.8	Output of Dead Zone Dynamics	64
Fig. 6.9	Input Current (Input Inductor current)	66
Fig. 6.10	Output Voltage (Volts)	69

56

67

LIST OF ABBREVIATIONS

DC-DC	Direct Current to Direct Current
PI	Proportional-Integral
PWM	Pulse Width Modulation
MOSFET	Metal Oxide Semiconductor Field Effect Transistor
CCM	Continuous Conduction Mode
KVL	Kirchhoff's Voltage Law
KCL	Kirchhoff's Current Law
MATLAB	Matrix Laboratory
S-ON	Switch ON
S-OFF	Switch OFF
D-ON	Diode ON
D-OFF	Diode OFF
IGBT	Insulated Gate Bipolar Transistor
DSP	Digital Signal Processors
EMI	Electromagnetic Interface
FPGA	Field Programmable Gate Array

33

8

LIST OF SYMBOLS

V_{in}	Input Voltage
V_o or V_{out}	Output Voltage
V_{ref}	Reference Voltage
I_L	Steady-State Inductor Current
i_L	Inductor Current
V_C	Steady-State Capacitor Voltage
v_C	Capacitor Voltage
L	Inductance
C	Capacitance
R	Resistance
R_{L1}, R_{L2}	Parallel Load Resistance 1,2
D	Duty Cycle / Duty Ratio
$d(t)$	Time-Varying Duty Cycle
$D_{sat}(t)$	Saturated Duty Cycle Output
$u(t)$	Controller Output Signal
K_p	Proportional Gain
K_i	Integral Gain
T_i	Integral Time Constant
K_u	Ultimate Gain
P_u	Ultimate Period
ω_o	Natural Frequency
ω_u	Ultimate Frequency
$G_c(s)$	Controller Transfer Function
$G_{vd}(s)$	Control-to-Output Transfer Function
s	Laplace Variable
x_1	State Variable Representing Inductor Current
x_2	State Variable Representing Capacitor Voltage
A	State Matrix
B	Input Matrix
A_{ON}	State Matrix During Switch ON Condition
B_{ON}	Input Matrix During Switch ON Condition
A_{OFF}	State Matrix During Switch OFF Condition
B_{OFF}	Input Matrix During Switch OFF Condition
t	Time
f_{sw} or F_{sw}	Switching Frequency
P	Proportional Controller Value
I	Integral Controller Value
V	Volt
A	Ampere
H	Henry
rad/s	Radian per Second
kHz	Kilohertz
μH	Micro Henry
μF	Micro Farad
Ω	Ohm
$G(j\omega)$	Frequency Response Transfer Function

G_{do}	DC Gain of Converter
π	Mathematical Constant Pi
ω	Angular Frequency
u	System Input
x	State Vector
dT	ON Time Duration
D_{min}	Minimum Duty Ratio
D_{max}	Maximum Duty Ratio
$e(t)$	Error Signal

CHAPTER 1

INTRODUCTION

1.1 INTRODUCTION

Power converters, which aim to provide a dc output voltage, have rapidly advanced during the past few decades. As a result, it is widely utilized in numerous industrial applications, including processing renewable energy, charging batteries, and personal computers, etc[1]. The dc-dc converter output voltage is regulated by continuously varying the quantity of energy injected into the load and absorbed from the source, which is determined by the relative lengths of the injection and absorption intervals[2].

Energy Storage (Switch ON) When the main switch (usually a MOSFET) is turned ON, it creates a path for current through the inductor, allowing the inductor to store energy in the form of magnetic field.

Energy Release (Switch OFF) When the switch is turned OFF, the inductor releases store energy by reversing its voltage polarity, redirecting current through a diode & charging the output capacitor, resulting in a higher output voltage than the input. By modifying the proportional gain (K_P) and integral gain (K_I) values appropriately, the PI controller controls the output voltage of the Boost converter to provide a quick transient response[3].

For reliable asymptotic tracking & disturbance rejection of constant external signals, proportional integral (PI) control is widely utilized. If the control gains are small enough and the plant satisfies certain stability requirements, closed-loop stability can be attained when the plant is an Nonlinear system. Global findings for PI control have been obtained by extending the theory to nonlinear systems[4]. This approach was accomplished using a combination of saturation functions & advanced PI controller[5].

When using just proportional control action, Ziegler & Nichols proposed methods for adjusting the PI controller (mean to set the values of K_P & K_I) based on the experimental step response or based on the value of K_P that results in marginal stability. The following is a quick presentation of Ziegler-Nichols rules, which are helpful when mathematical models of plans are unknown[6].

The proportional term (K_P) accelerates the response & shortens the system rise time by producing an output proportionate to the instantaneous mistake. By accumulating the error over time, the integral term (KI) eliminates steady-state error & guarantees that, despite variations in load or input, the output voltage settles precisely at the correct

reference. Two types of nonlinearities can also be implemented saturation & dead zone[7]. Both non linearity have different nature & different regions of operation, while saturation non linearity can be use to limit the duty cycle like wise lower limit of saturation is our minimum duty limit & upper limit of saturation is our maximum duty limit of converter. In case of dead zone non linearity the same rule applies: in this tiny difference, dead zone may start at minimum duty limit & dead zone may end at the maximum duty limit[8]. Both Nonlinearity & Further explanation can be done by using simulation & results of simulation for these.

Because of their efficient conversion and regulation of electrical energy for the application, DC-DC conversion units are one of the most indispensable components in modern electrical and electronic applications. The performance, energy efficiency and reliability of converters have been greatly enhanced in last decade due to the tremendous improvements in semiconductor devices, switching technologies, digital control systems and power electronic circuits. In recent years, significant advancement in semiconductor devices, switching technologies, digital control systems, and power electronic circuits has greatly enhanced the energy efficiency, performance, and reliability of the DC-DC converter [9,10]. These converters are thus used extensively in many industrial, commercial and domestic applications where stable operating DC power is needed. DC-DC converter is crucial in DC power supply systems to meet applications like renewable energy systems, electric vehicles, battery charging circuits, telecommunication systems, portable electronic devices, aerospace systems, industrial automation, computer power supplies and medical equipment, where energy management and voltage regulation are vital functions.

Distinctive voltage converter topologies include boost, buck and boost with CCD. There are various topologies of voltage converters and the type of boost converter is one of the most widely used voltage converter configurations that is able to increase or boost a low input DC voltage to a higher output DC voltage. Simple circuit configuration, low components[11], high efficiency, and compactness, continuous input current and ease to implementation are advantages of the boost converter. This enhances the use of boost converters in applications which demand the power supply voltage is lower than the input power supply voltage. Because of these benefits, boost converters are widely employed in

106

85

power supply systems in which the power supply requirement exceeds the available power supply voltage.

In renewable energy applications like a PV system and a fuel cell system, the output voltage could often be small, and fluctuating with the environmental process[12]. Therefore, boost converters are used to increase the voltage level to the required value for battery charging, grid integration, or load operation. Similarly, in electric vehicles and portable electronic systems, boost converters play a major role in regulating voltage and improving energy utilization efficiency. Because of the increasing demand for efficient power conversion systems, research on boost converter modelling, control, and nonlinear analysis has become highly important in the field of power electronics.

19 The operation of a converter regulates the output voltage by continuously controlling the amount of energy absorbed from the source and delivered to the load during each switching cycle[13]. This energy transfer process is achieved through the high-frequency switching operation of a semiconductor device, generally a MOSFET, which periodically changes the circuit operating condition states.

During the switch ON interval, MOSFET provides a closed conducting path[14]. As current flows through the inductor, Since the inductor opposes sudden changes in current, the inductor current increases gradually during this interval. At the same time, the diode becomes reverse biased, which prevents side of the converter[15]. Therefore, during the ON state, the capacitor connected across the load supplies the required energy to maintain output voltage continuity. This interval is commonly referred to as the energy storage mode because energy is accumulated inside the inductor.

65 During the switch OFF interval, the MOSFET and the conducting path through the switch is interrupted. However, the inductor opposes sudden reduction in current and starts releasing the stored magnetic energy by reversing its polarity[16]. As a result, Consequently, the output voltage becomes greater than the input voltage. The capacitor also gets recharged during this interval and helps maintain a smooth and stable output voltage with reduced ripple content. Thus, by continuously repeating the ON and OFF switching process, the boost converter achieves voltage boosting operation[17].

A higher duty cycle generally results in greater energy transfer and higher output voltage. However, the boost converter is a non-linear switching system and its dynamic behavior is complex under the different operating conditions[18]. For this reason, it is critical to design the controller correctly to ensure the stability of the converter, good transient response, low ripple content and good voltage regulation under various load conditions and disturbances. Closed-loop control is extensively applied in real boost converter systems for better converter performance. A closed-loop converter system is a system in which the output voltage is continually monitored and compared to a reference voltage. A closed-loop converter system is a converter system in which output voltage is constantly measured and compared to a desired reference voltage[19]. The voltage drop produces an error signal that is fed to the controller that changes the switching duty cycle to stabilize the output voltage regulation. In a closed loop system, the capability against disturbances becomes better, the steady state error is less, the transient response is better, and the overall reliabilities of the system is higher. For the power electronic converter, Proportional-Integral (PI) is one of the most commonly used and practically accepted control methods due to its simple structure, low computation burden, ease of implementation and good dynamic performance [20,21]. The proportional part of the PI controller acts on the instantaneous error, helping to make the system respond faster. It aids to lower the rise time and enhance the transient response when subject to any sudden interference or load changes. But there still remains a possibility of error with only proportional control. So the integral part was built into the controller such that the error builds up continuously with time and will remove the steady state error. The integral action guarantees that, no matter the operating condition, the voltage will be precisely the desired reference voltage[22]. Proper gains for the PI controller are needed for proper operation. If the controller parameters are not properly tuned, there may be too much overshoot, oscillations, slow transient response, higher settling time or instability[23]. Thus, one must look for controller tuning methods to find out the proper gains for the PI controllers. The Ziegler – Nichols method is a practical tuning method that is more useful in the absence of exact mathematical models of the system, and can be used in this research work. This approach offers a simple scheme for ensuring stable operation of the converter, with better transient response and minimal steady-state error[24]. In spite of the good voltage regulation that can be achieved with a PI controller, in reality, all power electronic converters are always subjected to nonlinear operating conditions that affect the performance of the system. Switching devices, sensors, actuators and control circuits

have physical constraints in real systems leading to nonlinearities in the converter's operation. The nonlinear effects can have a significant impact on the transient response, stability, disturbance rejection and voltage regulation performance. In real systems, converters, ideal linear assumptions are not always adequate to account for the actual converter behavior. Hence, the study of nonlinear dynamics involved in the converter analysis becomes significant to obtain realistic results of simulation & performance evaluation[25]. In this research, two significant nonlinearities are taken into account for analysis and simulation of the boost converter system, which are saturation and dead-zone nonlinearities. To ensure the controller output and duty cycle stays within reasonable limits, saturation nonlinearity is applied. In actual converters the switching duty ratio should not be allowed to go beyond the minimum and maximum values due to the fact that the semiconductor devices can operate only within a limited range. [26] Thus the saturation block will prevent too many switching instructions and prevent the converter components from getting unstable, overdriven, and into unsafe operating conditions. Saturation nonlinearity is arguably a realistic model of practical duty cycle and switching limitations [27]. A region where small control signals do not produce effective response of the system due to dead-zone nonlinearity[28] is given below. This behavior is seen very often in practical systems in the presence of switching thresholds, hardware insensitivity and actuator limitations[29]. If the signal value is below a steady state threshold in the dead-zone region, the value of the controller output is disregarded. Consequently, the converter response could be slow in small disturbances or transient operating condition[30]. Saturation and dead-zone nonlinearities have different operating characteristics and operate the converter in different ways. Effect of their effects on transient response, voltage ripple, settling time, disturbance rejection and system stability can be studied and examined by simulation studies. Therefore, if these nonlinearities are included in the modelling of the converters, a more realistic insight into real converter operation is obtained. The DC-DC boost converter is a closed-loop PI controlled converter studied in this research work, where matrix is used for modelling and analysis. In the developed simulation model, the boost converter, PI controller, PWM switching mechanism, feedback control loop, saturation nonlinearity, and the dead-zone nonlinearity are incorporated into the model. The effect of nonlinear dynamics on the stability of the converter, output voltage regulation, the inductor current, steady state response, ripple, and disturbance rejection is investigated through simulation analysis. The main goal of this research is to develop and study the closed loop performance of a

94 PI controlled DC-DC boost converter operating in a nonlinear regime and to explore the effect of the DC-DC boost converter saturation and dead-zone dynamics on the overall converter performance. The proposed system will provide a regulated output voltage of 400 V with minimal ripple content and operation stability under varying load condition. The result of the simulation in this work will give a significance suggestion about the action of the converter in a practical application and it will show the efficiency and stability of the PI controller under non-linear operating conditions[31].

1.2 RESEARCH BACKGROUND

109 Today's fast-growing power electronic applications require efficient, compact and reliable DC-DC power converter solutions to be available in the market. These type of converter are very significant in the electrical and electronic applications where voltage conversion and regulation are necessary[32]. Boost converter is one of the most widely employed topologies among the different types of DC-DC converters that can provide a high output voltage and yet operate from a low input voltage with a high efficiency. Boost converters are popularly used in various applications, including renewable energy, electric vehicles, battery charging stations, industrial automation, portable electronics, aerospace electronics, and distributed power generation, for these benefits. These days boost converters are even more important with the incorporation of renewable energy resources such as PV systems, fuel cells and battery energy storage systems. The conversion of most of the renewable energy sources produce comparatively low and intermittent DC voltages that are not sufficient for practical uses or integration in electricity grid [33]. Therefore, it is necessary to increase and regulate the voltage to the required value, which can be done by combining a boost converter. A stable output voltage under the different operating conditions such as load variation, source fluctuation, switching disturbances and parameter uncertainties is a big challenge in power electronic systems. These challenges are overcome by the advanced control techniques in boost converter system[34]. The concept of energy storage and transfer with inductive component is the basis for the operation of the boost converter. In the switching mode, the switching device (usually a MOSFET) is closed, and the energy from the input source can be stored in the coil as a magnetic field. When the switch is turned off, the stored energy is discharged through the diode and capacitor producing a higher output than input voltage. The output voltage can be efficiently controlled by using PWM to continually control the switching operation. The converter is typically operated in CCM where the

86

42

inductor current does not go to zero, to help achieve smooth current characteristics and greater system stability. [35]. Although the boost converter is a simple structure, it can be considered basically nonlinear dynamic. The mathematical analysis and controller design become more complicated when switching operation is performed at all times, as the circuit configuration will constantly change. In addition, there are many nonlinear effects in practical systems, such as switching limitation, actuator limitation, dead zone regions, saturation effect and nonidealities of the components[36]. Proportional-Integral (PI) controller is utilized in DC-DC converter to control the converter, which is one of the most recommended control method due to its simplicity, easy to implement and good performance in industrial applications. The proportional portion responds to the difference between the reference voltage and the output voltage at the instant of measurement, helping to improve the transient response. These properties make PI controllers very popular for voltage regulation applications of boost converters[37]. However the operating characteristics of a PI controlled boost converter are very sensitive to the values of the PI controller parameters. Excessive overshoot, oscillations, slow response, instability and/or poor disturbance rejection can result if these are not the correct tuning. In the literature, several tuning methods have been proposed, including the Ziegler-Nichols tuning method which is widely used as a practical, yet effective tuning method. The algorithm used by Ziegler-Nichols, which is used in this work, relates the gains of the controller to the ultimate gain and the ultimate oscillation period of the system[38]. This will provide a systematic procedure to specify the proportional gain, and integral gain to obtain a satisfactory transient and steady state response. In practical converter systems, the nonlinear constraints like saturation and dead zone effects are not negligible. Saturation nonlinearity is when the controller output (or duty cycle) reaches the physical extremes of the switching device. The duty cycle of a boost converter is not allowed to exceed a certain value and this value is known as the saturation. The duty cycle of boost converter cannot practically exceed a certain value and hence the notion of saturation is introduced, that is, saturation is a value that ensures that the switching signal stays within safe operating limits[39]. This will prevent over drive of switching devices and will prevent converter instability or destruction of switching circuit hardware. Saturation, however, introduces nonlinearities in the system as well, and can have an impact on the systems response to large transients or sudden load changes. Likewise, for the case of dead-zone nonlinearity there is a region of small output control signals that results in no output response. It is a common occurrence in practice for actuators, sensors,

26

51

21

switching devices and electronic control systems to be insensitive, have a threshold effect, or to suffer from hardware constraints. The dead-zone region has the potential to affect duty cycle generation in boost converters, and may cause slow duty cycle response, delayed duty cycle response to error, or poor duty cycle sensitivity to error. Hence, it is beneficial to include the dead-zone phenomena in the model of the converter, to obtain a realistic model of the real behavior of the system. Previous work on the control of boost converter has been based on idealized linear models, whereas very few of those have considered the impact of practical nonlinearities. Some nonlinear controllers such as sliding mode, fuzzy logic, adaptive control, MPC are proposed, but the above controllers are in general more complex and expensive to implement than the linear controllers. PI control is, however, still attractive for industrial application, because of its simplicity and reliability. Thus, the study of how well these boost converters with PI control operate in realistic, nonlinear situations is an important subject to investigate. In the present work, the performance analysis of a closed-loop PI controlled boost converter in the two important nonlinear cases, namely the saturation nonlinearity case and the dead-zone nonlinearity case are carried out. State space averaging and small-signal analysis techniques are used to mathematically model converter in continuous conduction mode operation[40]. The PI controller is designed by Ziegler-Nichols tuning method and some nonlinear constraints are also added to the control loop to analyse the effect of the nonlinear constraint on the system dynamics. A performance comparison of the converter for various loads is carried out by simulation using Matrix lab software. Inductor current, output capacitor voltage, are among the important state variables studied, whose influence of nonlinearities is investigated. The simulation results demonstrate that under nonlinear constraints and load disturbances, the proposed PI controlled system is able to maintain a good range of voltage regulation close to the reference value. The comparison of saturation nonlinearity with dead-zone nonlinearity is also done with respect to transient response, aspects of ripple, disturbance rejection, and the overall converter stability.

The research gives a contribution to design more practical and realistic control strategies for boost convertor. The adoption of nonlinear dynamics in the analysis enables the converter's behavior in the real operating environment to be better understood. The findings from this research may be useful for renewable energy systems, the powers electronics systems of electric vehicles, powers electronics systems in industries, and others in which stable voltage and efficiency are important[41]. In addition, the work

provides a basis for subsequent studies on the utilization of such advanced intelligent controllers, adaptive control methods and hardware implementation of the nonlinear converter control systems.

1.3 THESIS MOTIVATION

The converter is a very important component in the era of electrical/electronic devices which require reliable and efficient power systems with power conversion. One of the most commonly used converter topologies is the boost converter as it can increase the input voltage(s) to a regulated output voltage(s) by a more effective method. Stable operation of the boost converter is crucial to a wide range of applications such as charging systems for batteries[42], electric vehicles, renewable energy, portable electronics, aerospace electronics, and industrial automation. But it is a significant challenge to maintain the accuracy of voltage regulation in practical power electronic systems in cases that operating condition vary. Most practical applications involve nonlinearities like switching devices saturation, actuator constraints, and control constraints which affect boost converters. Such nonlinearities may become a major factor in the transient response, stability, ripple and disturbance rejection of the converter. In conventional studies, these practical nonlinear effects are ignored and studies are conducted under ideal assumptions, leading to a discrepancy with actual operation. Hence, it is imperative to study the converter's operation under real practical nonlinear operating conditions to enhance reliability and controller performance [43]. This research is focused towards understanding the nonlinear saturation and dead zone dynamics of the performance of a closed loop PI boost converter. Use of a PI controller is because of the simplicity, ease of implementation and industry acceptance. The goal of this work is to consider the robustness and efficiency of the PI control in realistic operating condition and then to exploit a nonlinear constraint in the control loop as well as to analyse the converter when a load disturbance occurs. With the requirement of an effective voltage regulation of a renewable energy source system in the field of power electronics, the requirement for fast transient response and pure steady-state performance and system stability encourages this research. The findings of this study can be applied to the improved design methodology of the converters and used as a starting point for future advanced practical power electronic control which are nonlinear and intelligent[44].

1.4 THESIS OBJECTIVES

This research aims to analyze and assess the performances of closed loop PI controlled boost converter under practical nonlinear operating conditions. The study is intended to show the converter dynamic behavior, stability and voltage regulation performance and explore the effects of the nonlinear phenomena such as saturation and dead-zone characteristics. The aim of the study is to gain insight into the dynamic performance, stability and voltage regulation performance of the converter and the influence of nonlinear components, including saturation and dead-zone, on these aspects. The other aim of the work is to include the nonlinear saturation and dead-zone dynamics into the converter control loop and investigate the influence of these dynamics on critical converter state variables such as the inductor current and output voltage. A simulation under different loading condition conducted using Matlab/Simulink tool on the proposed system and checked with it. Furthermore, by this work, a real-time working of this converter is practically analysed and the basis is laid for the future work using any advanced nonlinear adaptive and intelligent control technique for any power electronic converter.

1.5 THESIS ORGANIZATION

The thesis is organized into multiple chapters to provide a systematic presentation of the research work carried out on the performance analysis of a PI-controlled boost converter under nonlinear scenarios.

Chapter 1: Introduction

This chapter provides an introduction to DC-DC converters and highlights the importance of boost converters in modern power electronic applications. It discusses the need for voltage regulation, challenges associated with nonlinear dynamics, and the significance of PI control in converter systems. The chapter also includes the research motivation, objectives, scope of work, and overall problem statement addressed in this thesis.

Chapter 2: Design and Analysis of Boost Converter

This chapter reviews previous research related to boost converters, nonlinear control systems, PI controller applications, saturation dynamics, and dead-zone nonlinearities.

92 Different control strategies proposed in earlier studies are discussed along with their advantages and limitations. The chapter identifies the research gap that motivates the present work.

Chapter 3: Mathematical Modelling of Boost Converter

121 This chapter presents the detailed mathematical modeling of the boost converter operating in Continuous Conduction Mode (CCM). State-space averaging techniques and small-signal analysis are used to derive the converter equations and transfer function. The operating principles during switch ON and switch OFF conditions are also explained in detail.

Chapter 4: Design of PI Controller

89 This chapter presents the design & use of the PI controller for the closed-loop boost converter. The chapter also explains the role of the PI controller in improving transient response, reducing steady-state error, and maintaining stable converter operation. The working principle of proportional and integral control actions is discussed along with voltage regulation and controller tuning using the Ziegler–Nichols method.

Chapter 5: Nonlinear Dynamics

This chapter presents the analysis of nonlinear dynamics in the closed-loop boost converter system. The chapter mainly focuses on saturation and dead-zone nonlinearities and explains their practical significance and influence on converter performance. The effect of these nonlinearities on transient response, voltage regulation, and system stability is also discussed under practical operating conditions.

Chapter 6: Simulation and Performance Analysis

96 This chapter presents the matrix lab implementation of the proposed closed-loop boost converter system. Simulation results under saturation and dead-zone nonlinear conditions are analyzed in terms of output voltage response, inductor current behavior, ripple content, transient response, and load variation performance. Comparative analysis between both nonlinear cases is also included.

38

Chapter 7: Conclusion and Future Scope

This chapter summarize the major findings and conclusions obtained from the research work. It highlights the effectiveness of the PI-controlled boost converter under nonlinear operating conditions and discusses possible future research directions such as adaptive control, fuzzy logic control, sliding mode control, and hardware implementation for real-time validation.

1

CHAPTER 2

DESIGN & ANALYSIS OF BOOST CONVERTER

2.1 INTRODUCTION

These power electronic converters are responsible for efficient electrical energy conversion and regulation in today's electrical and electronic systems. Boost converter is one of the common topologies used among various topologies by most of the converter because of its ability to boost down lower DC voltage to up higher regulated output DC voltage. The boost converter's circuit configuration and ability to generate high voltage very efficiently and compactly combined with the ease of control has contributed to its importance in various industrial, commercial, and renewable energy applications.

High-performance power conversion systems are increasingly needed in recent years in battery charging systems, aerospace systems, portable electronic devices, communication equipment, and industrial automation systems. Photovoltaic systems, fuel cells and battery storage systems produce relatively low DC voltages[45,46] for most renewable energy sources. These low voltage levels are not practical to use and must be boosted to the load's useable voltage and/or the grid voltage before they can be used. In such applications, the boost converter plays a crucial role, delivering high efficiency and stable performance despite rising the voltage.

The boost converter circuit seems straightforward, but with the switching operation of semiconductors, the characteristics of the circuit are nonlinear. Thus, mathematical analysis and appropriate converter design are of importance when achieving an acceptable performance. The working modes of the converter have a significant impact on the performance of the system, its efficiency and the quality of the output voltage. However, before we discuss more complicated control strategies and the nonlinear analysis of systems in later chapters, it is important to appreciate these operating modes.

This chapter presents the detailed design and analysis of the boost converter used in this research work. The chapter explains the operating principle of the converter, switching modes of operation, converter design equations, component selection procedure, and performance considerations[47]. Theoretical analysis presented in this chapter forms the

foundation for the controller design, nonlinear analysis, and simulation studies discussed in later chapters.

2.2 BASIC CIRCUIT DIAGRAM OF BOOST CONVERTER

27

The basic boost converter consists of:

- Input DC voltage source
- Inductor (L)
- Semiconductor switch (MOSFET)
- Diode (D)
- Capacitor (C)
- Load resistance (R)

2.3 WORKING PRINCIPLE OF BOOST CONVERTER

Periodically turning the semiconductor device on and off at a high frequency is how the boost converter works. The inductor stores energy during one interval and transfers it to the output load and input supply during the other. Consequently, the output voltage rises above the input voltage[48].

The voltage conversion ratio of an ideal boost converter is given by:

$$V_o = \frac{V_{in}}{1 - D}$$

where:

$$V_o = \text{Output voltage}$$

$$V_{in} = \text{Input voltage}$$

$$D = \text{Duty cycle}$$

The equation shows that the output voltage increases with an increase in duty cycle.

2.4 MODES OF OPERATION OF BOOST CONVERTER

The boost converter operates in two major switching modes:

50

1. Mode I – Switch ON Condition
2. Mode II – Switch OFF Condition

These two modes continuously repeat according to the switching frequency.

2.4.1 Mode 1 – Switch ON Condition

In this mode of operation, the diode becomes reverse biased and the MOSFET switch is activated. The inductor is directly energized by the input voltage source, resulting in a linear increase in the inductor's current over time.

During this interval:

- The inductor stores energy in the form of a magnetic field.
- The diode blocks current flow toward the source.
- The capacitor supplies energy to the load.
- Output voltage slightly decreases depending on load demand.

Applying Kirchhoff Voltage Law (KVL):

$$L \frac{di_L}{dt} = V_{in}$$

The slope of inductor current becomes positive, resulting in increasing current.

Important Features of ON State

- Inductor charging occurs
- Diode remains OFF
- Capacitor discharges through load
- Energy is stored in magnetic form
- Output voltage support is provided by capacitor

2.4.2 Mode 2 – Switch OFF Condition

In this operating mode, the MOSFET switch is turned OFF. The inductor opposes sudden reduction in current and reverses its polarity. Due to this reversed polarity, the diode becomes forward biased[49].

During this interval:

- The inductor releases stored energy.
- Input source and inductor together supply power to the load.
- Capacitor charges again.
- Output voltage becomes greater than input voltage.

Applying Kirchhoff Voltage Law:

$$L \frac{di_L}{dt} = V_{in} - V_o$$

The inductor current decreases gradually during this interval.

Important Features of OFF State

- Inductor discharges energy
- Diode conducts current
- Capacitor charges
- Output voltage increases
- Energy transfer to load occurs

2.5 CONTINUOUS CONDUCTION MODE (CCM)

By analysing the waveform of the inductor current we can judge the boost converter mode or function is like it is in CCM or DCM. The inductor current in CCM operation never drops to zero throughout the switching cycle.

CCM operation offers several advantages:

- Reduced current ripple
- Improved voltage regulation
- Better efficiency
- Smooth converter operation
- Reduced stress on switching devices

2.6 DESIGN OF BOOST CONVERTER

95

The design of a boost converter mainly depends on:

- Input voltage
- Desired output voltage
- Load resistance
- Switching frequency

The parameters selected for this research work are shown below.

Table 2.1 Boost Converter Parameters

Parameter	values
V_{in}	48V
V_o	400V
R	106.67 Ω
L	292 μH
C	20 μF
f_{sw}	50kHz

2.6.1 Duty Cycle Calculation

The duty cycle determines the voltage boosting capability of the converter.

The duty ratio equation is:

$$D = 1 - \frac{V_{in}}{V_o}$$

Substituting the design values:

$$D = 1 - \frac{48}{400}$$

$$D = 0.88$$

Thus, approximately 88% duty cycle is required to obtain 400V output from a 48V input source.

2.6.2 Inductor Design

The inductor is a key component of the converter since it stores and transfers energy.

Inductor value is calculated using:

$$L = \frac{V_{in}D}{\Delta I_L f_{sw}}$$

The selection of proper inductance:

- Reduces ripple current
- Maintains CCM operation
- Improves converter stability
- Enhances efficiency

Very small inductance increases ripple current, while excessively large inductance increases converter size and cost.

2.6.3 Capacitor Design

The output capacitor reduces voltage ripple and maintains smooth DC output voltage.

Capacitor design equation:

$$C = \frac{I_o D}{\Delta V_o f_{sw}}$$

A properly selected capacitor:

- Minimizes voltage ripple
- Improves transient response
- Maintains output voltage stability

Larger capacitance improves filtering but increases system size and cost.

2.6.4 Switching Frequency Selection

Switching frequency strongly affects converter performance and component size.

Higher switching frequency:

- Reduces passive component size
- Improves transient response
- Reduces ripple content

However:

- Switching losses increase
- Thermal stress increases
- Converter efficiency may reduce

In this work, switching frequency is selected as:

$$f_{sw} = 50kHz$$

This provides a good balance between efficiency and converter size.

2.7 ADVANTAGES & LIMITATIONS OF BOOST CONVERTER

The major advantages of the boost converter are:

- Simple circuit structure
- High efficiency
- Compact design
- Continuous input current
- Easy control implementation
- Suitable for renewable energy applications
- Low component count

Despite several advantages, the boost converter also has some limitations:

- High duty cycle requirement at large voltage gain
- Increased switching losses

- Output voltage ripple
- Electromagnetic interference (EMI)
- Sensitivity to parameter variation
- Nonlinear dynamic behavior

These limitations motivate the use of advanced control strategies and nonlinear analysis discussed in later chapters.

2.8 PRACTICAL APPLICATIONS OF BOOST CONVERTER

Boost converters are widely used in:

- Solar photovoltaic systems
- Electric vehicles
- Battery charging circuits
- Fuel cell applications
- UPS systems
- LED drivers
- DC motor drives
- Aerospace power systems
- Industrial automation systems

6

2.9 CHAPTER SUMMARY

In this chapter present the detailed design & operational analysis of the boost converter. The basic converter structure and working principle were explained in detail. The two switching modes of operation, mainly name as switch ON & OFF mode, were discussed along with energy storage and energy transfer mechanisms.

The chapter further explained Continuous Conduction Mode operation and highlighted its importance in improving converter performance and reducing ripple content. Design procedures for important converter parameters such as D, L, C & switching frequency were also presented using standard design equations.

In addition, the advantages, limitations, and practical applications of the boost converter were discussed. The theoretical concepts and design methodology explained in this

chapter provide the necessary foundation for mathematical modeling, controller design, nonlinear analysis, and simulation studies presented in subsequent chapters of this thesis.

4

CHAPTER 3

MATHEMATICAL MODELLING OF BOOST CONVERTER

3.1 INTRODUCTION

The mathematical modeling of a boost converter is an important ingredient when understanding, analyzing and predicting the dynamic behaviour of the converter as a function of operating conditions. Because the boost converter is a nonlinear switching system, mathematical modelling is an approach that can be used to represent the converter using mathematical equations and dynamic relationships between voltage, current, switching action and energy storage components. The successful design of a controller, stability analysis, transient analysis, evaluation of controller performance and computer studies require accurate mathematical modelling. For a boost converter, the switching occurs continuously, and the switching from various operating states of the semiconductor devices happens in periodic manner. Because of this switching action, the converter has a nonlinear behavior, hence the analysis of this behavior is not easy. Hence, mathematical models are designed to ease the representation of the system with acceptable accuracy for modeling, analysis and controller design. These models help in understanding the relationship between IV, OV, inductor current, capacitor voltage, duty ratio & load variations[50]. In typical mathematical modelling, circuit equations for the various switching modes are developed from basic electrical circuit laws which are known as KVL & KCL. A converter is analyzed separately in switch ON and switch OFF conditions and the resulting equations are averaged to get an overall dynamic model. We choose the used method, since it will give the converter dynamics properly in practice analysis. The state space model of the boost converter is built using the variables of voltage in the capacitors and current in the inductor. The state variables indicate the energy storage characteristics of the converter and enable a dynamic analysis of the circuit. State space modelling offers a number of benefits such as: simple controller design, transient analysis, small-signal analysis, stability analysis, and a derivation of the transfer function. It also forms the basis for implementing advanced control[51,52]. However, state-space modelling is not the only method of modelling a converter that is important, another important method is the small-signal modelling of the converter

126

41

16

around a desired steady-state operating point. Small signal analysis makes the converter equations linear by adding small perturbations to the steady state values. Using this method one can derive transfer functions that can be utilized for frequency-domain analysis and controller tuning. The small-signal model is used to analyze the stability of the system, transient response, bandwidth and disturbance rejection capability. The effectiveness of the mathematical modelling directly influences the performance of the overall converter and control system. Hence, correctly modeling the converter parameters that include load resistance, duty ratio, switching frequency, inductance and capacitance is essential. Mathematical models are also used to forecast the converter's behavior in the other operating conditions, with different load, under input disturbances and under nonlinear operating conditions. In the Boost Converter operating in Continuous Conduction Mode[53] detailed mathematical modelling is presented. Modelling procedure includes deriving the circuit equations for various switching states, formulation of averaged state space equations and formulation of small signal model.

3.2 MATHEMATICAL MODELLING

The circuit represented in Figure 3.1 illustrates the operation of the boost converter under two different switching conditions. Since the boost converter operates through high-frequency switching of the MOSFET, the converter behavior changes continuously depending upon whether the switch is in ON state or OFF state. Therefore, for proper mathematical analysis and understanding of converter dynamics.

Figure 3.2 represents the first way of operation is to turn on the MOSFET switch and reverse bias the diode. Through the closed switch circuit, the inductor receive direct energy from the input voltage source during this time[54]. The inductor current steadily increases over time as a result of energy being stored in the form of a magnetic field as current passes through the inductor. The output side of the diode gets electrically isolated from the input side because the diode is reverse biased in this situation. As a result, during this time, the capacitor provides the load with the necessary energy. Because the capacitor alone can supply the load current in this mode, the capacitor voltage somewhat drops in response to the load demand.

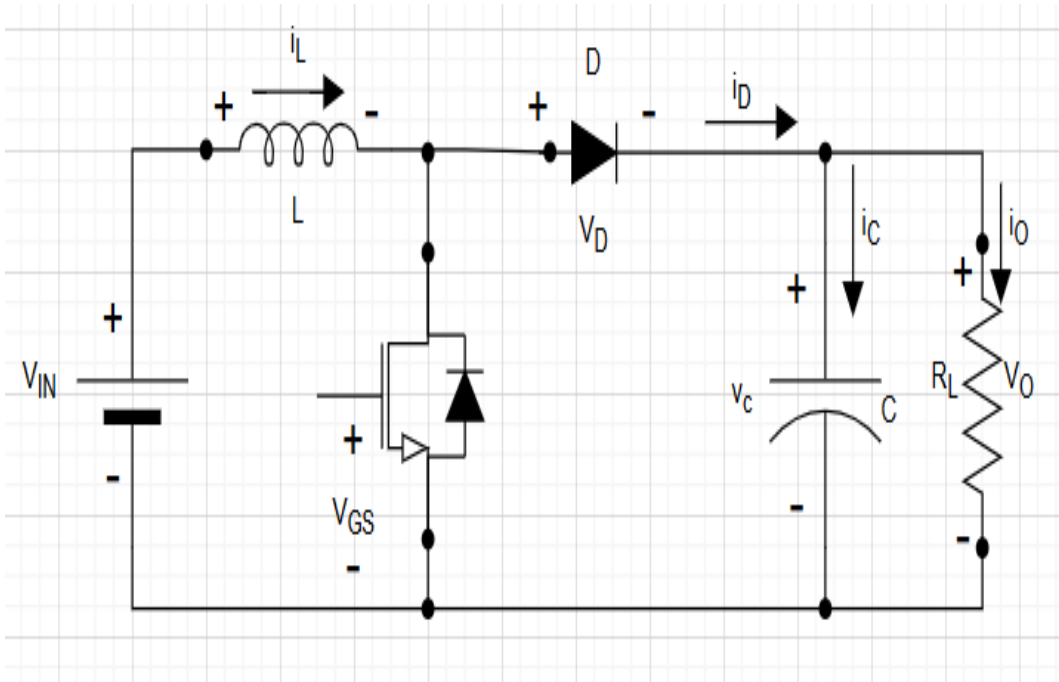

Fig 3.1 Boost Converter

During the first way of operation, the semiconductor switch (MOSFET) is turned ON while the diode becomes reverse biased and remains OFF. This operating interval is commonly referred to as the ON-state or energy storage mode of the boost converter. In this condition, the switch provides a closed conducting path between the input source and the inductor[54],

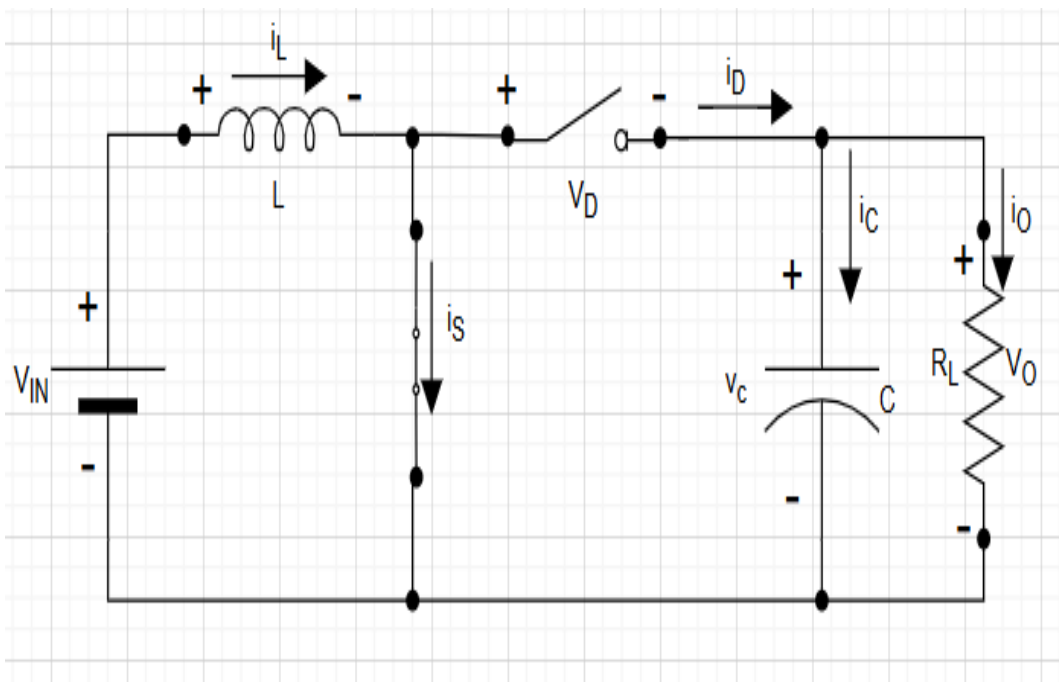

Fig 3.2 First Mode of Operation (Switch ON, Diode OFF)

107 When the switch of the boost converter is turned ON, a closed path is created between the input voltage source, inductor, and semiconductor switch. Because of this closed path, current starts flowing from the input source through the inductor & the switch. As current flows through the inductor, it starts storing energy in the form of a magnetic field. The stored energy gradually increases throughout the ON duration of the switch. Since an inductor opposes sudden changes in current, the inductor current rises gradually instead of increasing instantly.

36 During this interval, the diode becomes reverse biased due to the polarity developed across the circuit. As a result, the diode blocks current flow toward the output side and electrically separates the input section from the output section of the converter. Therefore, the energy from the source and inductor cannot directly reach the load during this operating condition.

At the same time, the capacitor connected across the load starts supplying its previously stored energy to maintain the output voltage. In this condition, the capacitor acts as a temporary energy source for the load because the output side is isolated from the input side by the reverse-biased diode. As the capacitor delivers energy to the load, its stored charge slowly decreases. However, if the capacitance value is sufficiently large, the output voltage remains nearly constant with very small ripple.

53 Thus, during the switch ON condition, two important processes occur simultaneously. First, the inductor absorbs and stores energy from the input supply. Second, the capacitor releases its stored energy to continuously support the load. This operating interval is commonly known as the energy storage mode of the boost converter because energy is accumulated in the inductor for transfer to the output during the next switching interval when the switch turns OFF.

Taking the state variables:-

$$x_1 = i_L(t) \quad (1)$$

$$x_2 = v_C(t) \quad (2)$$

Writing KVL in first loop,

The voltage on the inductor of the boost converter circuit, from the equation it is known as the switch current (I_s) is equal to the inductor current (I_L) [8].

$$L \frac{di_L}{dt} = V_{in} \quad (3)$$

Putting (1) in (3),

$$\frac{dx_1}{dt} = \frac{V_{in}}{L} \quad (4)$$

Writing KCL in the second loop,

Where the value of the capacitor voltage (V_C) is equal to the value of the output voltage (V_O) [8].

$$C \frac{dv_C}{dt} = -\frac{v_C}{R} \quad (5)$$

Putting (2) in (5)

$$\frac{dx_2}{dt} = -\frac{x_2}{RC} \quad (6)$$

During the second mode of operation, the semiconductor switch (MOSFET) is turned OFF while the diode becomes forward biased and starts conducting. This operating condition is commonly known as the OFF-state or energy transfer mode of the boost converter. When the switch is turned OFF, the direct conducting path between the input source and the switch is interrupted. However, the current flowing through the inductor cannot stop suddenly because an inductor always opposes abrupt changes in current.

During the previous ON interval, the inductor stored energy in the form of a magnetic field. As soon as the switch turns OFF, the magnetic field around the inductor begins to collapse. To maintain continuous current flow, the inductor reverses its polarity and starts releasing the stored energy toward the output side of the converter. This reversed polarity forward biases the diode, allowing current to flow through the diode, capacitor, and load resistance.

112 In this interval, both the input voltage source & the energy released from the inductor
28 simultaneously supply power to the load. Because the inductor voltage adds to the input
105 source voltage, the output voltage becomes higher than the input voltage. This is the basic
principle behind the voltage boosting capability of the boost converter[55].

At the same time, the capacitor connected across the load also starts charging again using
the energy supplied by the source and inductor. The capacitor stores energy and helps
maintain a smooth and stable output voltage with reduced ripple content. Since the
capacitor continuously supports the load during both switching intervals, uninterrupted
power delivery to the load is achieved.

During this operating mode, the inductor current gradually decreases because the stored
magnetic energy is continuously transferred to the output side. However, the current
decreases smoothly rather than abruptly due to the inductive property of the inductor.

58 Thus, during the switch OFF condition, the boost converter performs the important
54 function of transferring the energy previously stored in the inductor to the output side.
This interval is therefore known as the energy transfer mode of operation. The continuous
switching between ON and OFF states allows the converter to maintain a boosted and
regulated output voltage according to the desired operating conditions.

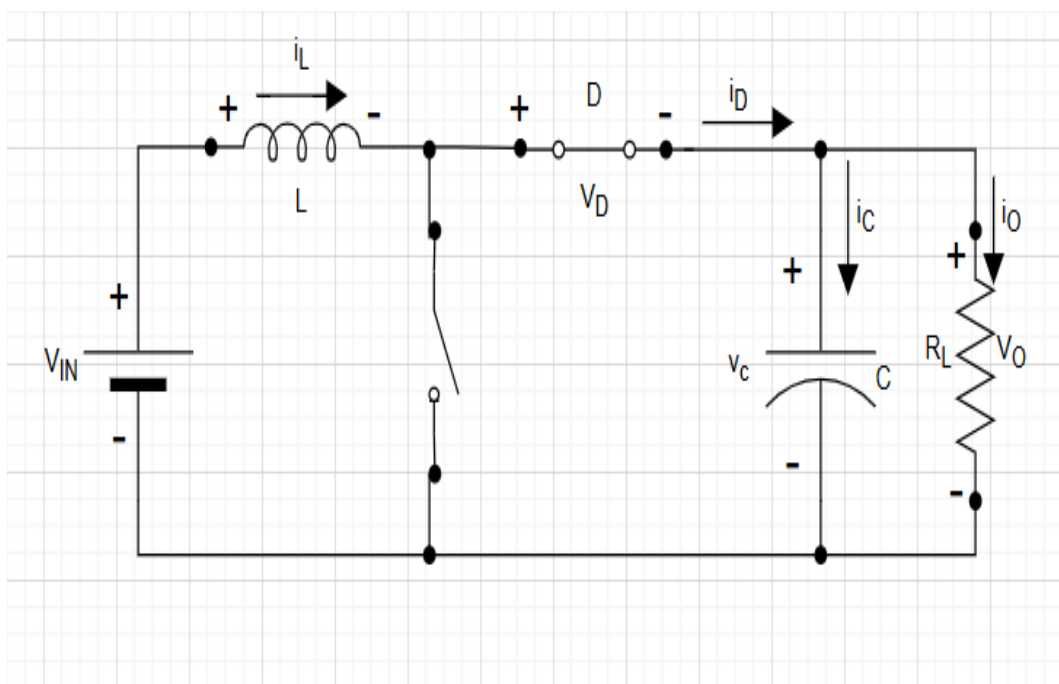

Fig 3.3 Second Mode of Operation (Switch OFF, Diode ON)

15 When the switch of the boost converter is turned OFF, the direct conducting path between the input source and the switch is interrupted. However, the current flowing through the inductor cannot stop instantaneously because an inductor naturally opposes sudden changes in current. During the previous ON interval, the inductor stored energy in the form of a magnetic field. As soon as the switch turns OFF, the magnetic field around the inductor begins to collapse, and the inductor starts releasing its stored energy in order to maintain current continuity in the circuit.

12 At this moment, the polarity across the inductor reverses automatically, which causes the diode to become forward biased and conduct current. Once the diode conducts, a new current path is formed through the diode, capacitor, and load resistance. In this operating condition, the energy released by the inductor combines with the energy supplied by the input voltage source and both together transfer power to the output side of the converter.

16 During this same interval, the capacitor connected across the output side also gets recharged. Consequently, when the switch turns OFF, a larger amount of stored energy is transferred to the output side, resulting in a higher output voltage. Therefore, by controlling the duty cycle of the switching signal[56], the boost converter can regulate the output voltage according to system requirements.

7 Thus, during the switch OFF condition, the converter performs the important task of transferring the stored energy from the inductor to the output side while simultaneously recharging the capacitor and supplying power to the load. This interval is commonly referred to as the energy transfer mode of the boost converter operation.

Writing KVL in the first loop,

$$L \frac{di_L}{dt} = V_{in} - v_c \quad (7)$$

7 Putting (1) in (7), the average model of an idealized boost converter in the continuous conduction mode with state variables is given, [10]

$$\frac{dx_1}{dt} = \frac{V_{in} - x_2}{L} \quad (8)$$

Writing KCL in the second loop,

$$C \frac{dv_c}{dt} = i_L - \frac{v_c}{R} \quad (9)$$

Putting (2) in (9), the average model of an idealized boost DC-DC converter in the continuous conduction mode with state variables is given, [10]

$$\frac{dx_2}{dt} = \frac{x_1}{C} - \frac{x_2}{RC} \quad (10)$$

Averaged state space model (CCM):-

$$\frac{dx}{dt} = Ax + Bu \quad (11)$$

$$X = [x_1 \ x_2] \quad (12)$$

$$u = Vin \quad (13)$$

Case 1: When S is ON

Using (4) & (6), Putting (13) in (4),

$$\frac{dx_1}{dt} = \frac{u}{L} \quad (14)$$

Using (14), (6) & (11) to represent the state space matrix,

$$A_{ON} = \begin{bmatrix} 0 & 0 & 0 & -\frac{1}{RC} \end{bmatrix} \quad B_{ON} = \begin{bmatrix} \frac{1}{L} & 0 \end{bmatrix} \quad (15)$$

Case 2: When S is OFF

Put (13) in (8), so we get

$$\frac{dx_1}{dt} = \frac{u - x_2}{L} \quad (16)$$

Using (16) & (10), In equations (11), (12) & (13) with the state, input & output variables mentioned before, can be put in matrix form as follows[9],

$$A_{OFF} = \begin{bmatrix} 0 & -\frac{1}{L} & \frac{1}{C} & -\frac{1}{RC} \end{bmatrix} \quad B_{OFF} = \begin{bmatrix} \frac{1}{L} & 0 \end{bmatrix} \quad (17)$$

Using (15) & (17) so we get A & B,

$$A = DA_{ON} + (1 - D)A_{OFF}$$

$$A = \left[0 \quad -\frac{(1 - D)}{L} \quad \frac{(1 - D)}{C} \quad -\frac{1}{RC} \right] \quad (18)$$

$$B = DB_{ON} + (1 - D)B_{OFF}$$

$$B = \left[\frac{1}{L} \quad 0 \right] \quad (19)$$

3.3 DERIVE A SMALL SIGNAL MODEL OF A BOOST CONVERTER (CCM OPERATION)

During S-ON, D-OFF ($0 < t < dT$)

$$L \frac{di_L}{dt} = V_{in} \quad (20)$$

$$C \frac{dv_o}{dt} = -\frac{v_o}{R} \quad (21)$$

During S-OFF, D-ON ($dT < t < T$)

$$L \frac{di_L}{dt} = V_{in} - v_o \quad (22)$$

$$C \frac{dv_o}{dt} = i_L - \frac{v_o}{R} \quad (23)$$

101 Generalizing the average State equation, using the inductor current equation with respect to time & capacitor voltage equation with respect to time,

$$L \frac{di_L}{dt} = d \cdot V_{in} + (1 - D) \cdot (V_{in} - v_o)$$

$$= V_{in} - (1 - D) v_o \quad (24)$$

$$C \frac{dv_o}{dt} = d \cdot \left(-\frac{v_o}{R} \right) + (1 - D) \cdot \left(i_L - \frac{v_o}{R} \right)$$

$$= (1 - D) i_L - \frac{v_o}{R} \quad (25)$$

Using (24) & (25), so we get steady state operating point,

$$i_L(t) = I_L + \hat{i}_L(t)$$

$$v_o(t) = V_o + \hat{v}_o(t)$$

$$d(t) = D + \hat{d}(t)$$

Writing an equation for inductor current with respect to time, in which the input current is equal to the inductor current,

$$L \frac{d\hat{i}_L}{dt} = -(1 - D)\hat{v}_o + V_o \hat{d} \quad (26)$$

Writing an equation for the output voltage as a capacitor voltage with respect to time,

$$C \frac{d\hat{v}_o}{dt} = (1 - D)(\hat{i}_L) - I_L \hat{d} - \frac{\hat{v}_o}{R} \quad (27)$$

Using (26) & (27), so we get a small signal state space representation,

$$\frac{d}{dt} [\hat{i}_L \ \hat{v}_o] = \begin{bmatrix} 0 & -\frac{(1-D)}{L} \\ \frac{(1-D)}{C} & -\frac{1}{RC} \end{bmatrix} [\hat{i}_L \ \hat{v}_o] + \begin{bmatrix} \frac{V_o}{L} \\ -\frac{I_L}{C} \end{bmatrix} \hat{d} \quad (28)$$

Using (26) & (27), applying the Laplace transformation in null initial conditions, one obtains the following transfer functions,[9]

$$sL\hat{i}_L(s) = -(1 - D)\hat{v}_o(s) + V_o \hat{d}(s) \quad (29)$$

$$sC\hat{v}_o(s) = (1 - D)\hat{i}_L(s) - \frac{1}{R}\hat{v}_o(s) - I_L \hat{d}(s) \quad (30)$$

Now, solve for $\frac{\hat{v}_o(s)}{\hat{d}(s)}$,

Using (29),

$$\hat{i}_L(s) = \frac{-(1 - D)\hat{v}_o(s) + V_o \hat{d}(s)}{sL} \quad (31)$$

By rearranging the above equation, we get the generalized transfer function of the small signal model of the boost converter in continuous conduction mode,

$$G_{vd(s)} = \frac{(1-D)V_o(1-s\frac{LI_L}{(1-D)V_o})}{LCS^2 + \frac{L}{R}S + (1-D)^2} \quad (32)$$

Using table 3 values & put in (32), so we get

$$G_{vd(s)} = \frac{48 - 0.009124715s}{5.84 \times 10^{-9}s^2 + 2.7374 \times 10^{-6}s + 0.0144} \quad (33)$$

3.4 CHAPTER SUMMARY

In this chapter presented the mathematical modelling of the boost converter operating in CCM. The modelling process was carried out by analyzing the converter under two different switching conditions: switch ON & OFF state. The operational behavior of the converter during both intervals was discussed in detail to understand the flow of energy, current variation, and voltage boosting mechanism.

The chapter explained how the inductor stores energy during the ON state and releases the stored energy during the OFF state to achieve output voltage greater than the input voltage. Using fundamental electrical laws, the dynamic equations governing the converter operation were derived for each switching interval. These equations were then combined using the state-space averaging technique to obtain an averaged mathematical model of the converter.

The state variables such as inductor current and capacitor voltage were selected to represent the dynamic behavior of the system. The averaged state-space model developed in this chapter provides an effective method for analyzing converter stability, transient response, and control system performance. In addition, the small-signal model of the boost converter was also discussed to linearize the nonlinear switching behavior. The small-signal analysis helped in deriving the transfer function, which is useful for controller design and frequency-domain analysis.

Overall, the mathematical modelling presented in this chapter establishes the theoretical foundation required for the design of the PI controller, implementation of nonlinear dynamics, and simulation analysis discussed in the subsequent chapters.

CHAPTER 4

DESIGN OF PI CONTROLLER

4.1 INTRODUCTION

127 The performance and stability of a boost converter is strongly influenced by the effectiveness of its control. The boost converter is high-frequency switching in nature and the behavior of its dynamics is nonlinear, therefore it is crucial to use a suitable controller to achieve a stable and regulated output voltage under different operating conditions. In real-world scenarios, converters face constant perturbations including variations in load currents, input voltage, parameter uncertainties, switching effects, and nonlinear operating points. Hence a suitable control system is required for reliable operation, quick transient response, less ripple content and accurate voltage regulation of the converter. Due to the ease of implementation, low computational requirement and satisfactory dynamic performance, among the various control techniques available for PE converters, the PI method is chosen. The PI controller constantly compares the value of the reference voltage to the measured output voltage and produces a control voltage to reduce the difference between the two. This integral part of the controller reduces steady-state error and the proportional part increases the speed of the system response by reacting to changes in error instantaneously, thus reducing rise times. The above features make the PI controller very stable and error-free in many industrial and commercial applications.

26 In boosting systems with power electronics e.g. boost converter, the tuning of the parameters of the controller is of the most important as the performance of the overall system depends greatly on the proportional and integral gains selected. When a system is improperly tuned, it can result in excessive overshoot, oscillations, slow response, instability, longer settling time or poor disturbance rejection. Hence, various techniques to tune the controller parameters to yield a satisfactory converter performance are employed. The objective in this research is to design the PI controller to give a regulated output voltage while enhancing the dynamic response and minimizing the steady state error under various operating conditions[55]. Conventional PI type controllers are sufficient to ensure a good voltage regulation in practice, however, some nonlinear characteristics must not be overlooked when analysing and designing a boost converter system. Nonlinearities are found in real power electronic systems as a result of the

limitations of switching devices, duty cycle constraints, actuator saturation, dead-zone effects, nonidealities of components, and limitations of sensors. The nonlinear effects have a substantial effect on the converter dynamics, and can even affect the stability of the system, the transient response, the ripple characteristics, and overall converter performance. Saturation nonlinearity is one of the important nonlinear effects that are being considered in this work. However, in practical converters, the duty cycle can never exceed certain physical limits due to the limitation that switching devices can only operate within a limited range. To limit the duty cycle in a safe operating range, and to avoid excessive control action and hence damage to converter components or instability, saturation nonlinearities are added. Saturation adds protection and operation safety but also brings nonlinear behaviour into the system which can impact the converter response under large perturbations and/or transient conditions. Dead-zone non-linear property is another non-linear property analysed in this work. A dead zone is an area which has a small change in the input control signal, but no corresponding change in output response. Switching thresholds, sensitivity of actuators, and limitations on sensors and/or hardware are common causes for this behavior in practical systems. If ignored when analysing the system, dead-zone effects on the controller sensitivity in boost converters can result in sluggish transient response. The study of nonlinear dynamics in the analysis of a converter can give a better description of the practical operating conditions. Real-world converters always have nonlinear constraints, but most conventional analyses are based on ideal linear behavior. Hence, the knowledge of the influence of saturation and dead-zone nonlinearities becomes useful when considering real-world constraints on converter systems and assessing the performance of the PI controller in real-world scenarios. In the following chapter it is presented in detail how to design the PI controller of boost converter and the implementation of nonlinear dynamics inside the control loop is discussed. The chapter covers the action of proportional and integral actions in voltage regulation and the significance of the correct tuning of the controller to ensure stable converter operation. Further, the nonlinearities of saturation and dynamics of dead zone are addressed in great detail, their practical implications are discussed, and their effect on the converter behavior is discussed. Concepts discussed in this chapter provide the basis for closed loop boost converter simulation analysis and performance evaluation under the nonlinear operating conditions. The nonlinear implementation and the controller design presented here will be further used in later chapters for detailed MATLAB/Simulink

simulations, transient analysis, ripple analysis and comparison between converter performance in various nonlinear scenarios.

4.2 DESIGN OF PI CONTROLLER FOR BOOST CONVERTER

Boost converter systems typically employ a PI controller for control due to its combination of simplicity, stability, and strong performance capability. The most significant requirements in the closed-loop power electronic system are to maintain an output regulated and constant voltage. In reality, many perturbations like fluctuations in the input voltage, sudden load changes, switching effects, parameter changes in components, and nonlinear operating conditions always come into effect in practical boost converter circuits. It is possible for these disturbances to result in deviations from the output voltage and a decrease in system performance if appropriate control techniques are not used. Thus, a PI controller is utilized to make sure the output voltage is regulated constantly so as to optimize the converter performance for various operating conditions[55].

In a closed-loop boost converter system, the PI controller continuously compares the desired reference voltage with the actual converter output voltage. The difference between these two signals is called the error signal. Based on this error, the controller generates an appropriate control action to adjust the duty cycle of the switching device. By continuously controlling the switching duty ratio.

The PI controller consists of two important control actions:

- Proportional action
- Integral action

Both actions work together to improve converter performance and ensure accurate voltage regulation.

4.3 PROPORTIONAL ACTION (K_P)

The proportional component of the controller is an instantaneous response to the value of the error signal. Proportional action results in a corrective control signal proportional to the size of the error as long as there is an error—that is, when the output

voltage deviates from the reference voltage. This step will reduce the converter's rise time and improve its transient response to an extent. [56].

The major functions of proportional control are:

- Improves system response speed
- Reduces rise time
- Enhances transient response
- Quickly reacts to load disturbances
- Improves dynamic performance
- Reduces output voltage deviation

A higher proportional gain generally results in faster system response and improved disturbance rejection capability. However, excessively large proportional gain may produce:

- Oscillations
- Overshoot
- Instability
- Increased ripple content

Therefore, proper selection of proportional gain is necessary to achieve stable converter operation.

4.4 INTEGRAL ACTION (K_I)

The integral part of the controller continuously accumulates the error over time and generates an additional control signal that helps eliminate steady-state error. In practical systems, small voltage errors may remain even after the transient response settles. The integral action removes these remaining errors and ensures that the output voltage reaches exactly the desired reference value[56].

The major functions of integral control are:

- Eliminates steady-state error
- Improves voltage regulation accuracy
- Maintains output voltage stability

- Compensates for load variations
- Enhances long-term system accuracy
- Maintains output voltage at desired reference value

Although integral action improves steady-state performance, excessive integral gain may lead to:

- Slow transient response
- Increased settling time
- Oscillatory behavior
- Reduced system stability

Therefore, careful tuning of integral gain is also important for obtaining satisfactory converter performance.

4.5 COMBINED EFFECT OF PI CONTROLLER

Accurate steady-state performance and quick dynamic reaction are both possible when proportional and integral control work together. While the integral action eliminates steady-state error and increases voltage regulation precision, the proportional action speeds up reaction.

The overall advantages of the PI controller include:

- Simple structure
- Easy implementation
- Low computational complexity
- Stable converter operation
- Fast transient response
- Accurate voltage regulation
- Reduced steady-state error
- Improved disturbance rejection capability
- Suitable for industrial applications

Because of these advantages, PI controllers are extensively used in:

- DC-DC converters

- Renewable energy systems
- Battery charging circuits
- Electric vehicle applications
- Motor drive systems
- Industrial power supplies
- Voltage regulation systems

Another important advantage of the PI controller is that it can be easily implemented using analog circuits, microcontrollers, or digital signal processors. Due to its simplicity and effective performance, the PI controller remains one of the most preferred control methods in power electronic converter applications.

Proper tuning of PI controller parameters is extremely important because incorrect parameter selection may result in:

- Excessive overshoot
- Poor transient response
- Increased settling time
- Oscillations
- Instability
- Higher ripple content

Therefore, suitable tuning methods are used to determine appropriate controller gains for achieving stable operation and improved converter performance.

Overall, the PI controller provides an effective and reliable solution for controlling the output voltage of the boost converter. It improves voltage regulation capability, enhances transient response, reduces steady-state error, and ensures stable converter operation under different operating conditions.

- Proportional term (K_p) provides an output proportional to the instantaneous error, speeding up the response & reducing the rise time of the system.
- Integral term (K_i) accumulates the error over time, eliminating steady-state error and ensuring the output voltage settles exactly at the desired reference, even with load changes or input fluctuations.
- The PI controller output is given by:

$$u(t) = K_p \cdot e(t) + K_i \int_0^t e(t) dt$$

where $e(t)$ is the error signal ($V_{ref} - V_{out}$)

4.6 CALCULATING PI VALUES USING THE ZIEGLER–NICHOLS METHOD

Among the most popular and effective ways to tune PI controllers in control systems and power electronics, the Ziegler–Nichols method is one of them. This method gives a systematic approach which allows the selection of appropriate controller parameters to gain stable operation, reasonable transient response and better voltage regulation. The Ziegler–Nichols tuning method is widely used in the industrial process control, motor drive, and converter industry owing to its simplicity and effectiveness. For a boost converter system, the proportion and integral gains play an important role in the overall performance of the converter, hence the gains of the controller must be tuned properly. If the controller is set incorrectly, then there will be an excessive amount of overshoot, oscillations, slow transient response, large settling time, poor disturbance rejection capability, or even instability. Hence, the Ziegler–Nichols method is employed to obtain appropriate controller parameters for the PI controller which would yield a balanced performance. The fundamentals of the Ziegler–Nichols method are based upon examining the dynamics of the system and calculating two meaningful parameters—the ultimate gain and the ultimate period. The ultimate gain is the maximum proportional gain at which continuous sustained oscillations begin and the ultimate period is the time at which these are sustained[56]. In this tuning strategy, the integral action and derivative action are first switched off leaving the system only the proportional portion of the control feedback in effect. This is followed by a slow and steady increase in the proportional gain value to a higher value with continued monitoring of the system response. A proportional gain larger than 1 produces a faster system response, which, in turn, results in more oscillations. Eventually, there is a point at which the output waveform has constant amplitude steady oscillations. This mode of operation is called marginal stability condition.

The Ziegler–Nichols method offers several advantages:

- Simple and easy tuning procedure

- No need for complex mathematical calculations
- Suitable for practical systems
- Provides quick estimation of controller gains
- Improves transient response
- Reduces steady-state error
- Enhances overall converter stability

The method is particularly useful in boost converter systems because converter dynamics may vary with operating conditions and load changes. By experimentally determining the system response, the controller gains can be adjusted more effectively for practical operation.

However, the Ziegler–Nichols method also has some limitations. Since the method is primarily designed to achieve fast response, the resulting controller parameters may sometimes produce higher overshoot or oscillatory behavior. Therefore, in practical applications, further fine-tuning of the obtained gains may be required to achieve the desired balance between stability, transient response & voltage regulation accuracy.

1 In this research work, the Ziegler–Nichols method is used to determine the proportional & integral gains of the PI controller for the boost converter system. The obtained controller parameters are selected to provide stable operation, fast response, reduced settling time, and accurate output voltage regulation under varying operating conditions and nonlinear scenarios.

$$W_o = \frac{1 - D}{\sqrt{LC}} = 1570 \text{ rad/s} \quad (34)$$

$$W_u = \sqrt{2} \times 1570 = 2220.7 \text{ rad/s} \quad (35)$$

$$|G(jw)| = Gd_o = \frac{V_o}{1-D} = 3333.33 \quad (36)$$

$$K_u = \frac{1}{|G(jw)|} = \frac{1}{3333.33} = 0.00030 \quad (37)$$

Using (35) for calculating ultimate period,

$$P_u = \frac{2\pi}{W_u} = \frac{2\pi}{2220.7} = 0.00282937 \quad (38)$$

Taking formulas from ziegler nichlos table for calculating PI values,

$$K_p = 0.45K_u \quad T_i = \frac{P_u}{1.2} \quad K_i = \frac{K_p}{T_i}$$

Using (37) to calculate gain,

$$K_p = 0.45 \times 0.00030 = 0.0001350 \quad (39)$$

Using (38) to calculate the integral time constant,

$$T_i = \frac{P_u}{1.2} = \frac{0.00282937}{1.2} = 0.00235780 \quad (40)$$

Using (39) & (40) to calculate integral gain

$$K_i = \frac{K_p}{T_i} = \frac{0.0001350}{0.00235} = 0.057256 \quad (41)$$

$$G_{c(s)} = K_p + \frac{K_i}{s} = 0.0001350 + \frac{0.0572565}{s}$$

Using Duty limit (0 – 0.88) for calculating saturated values,

$$Scale = \frac{1}{0.88} = 1.1363$$

$$K_{u\ sat} = K_u \times Scale = 0.0003409$$

$$K_{p\ sat} = 0.45 \times K_{u\ sat} = 0.0001534$$

$$T_i = \text{Does not change}$$

$$K_{i\ sat} = \frac{K_{p\ sat}}{T_i} = 0.05064s^{-1}$$

Final values of P&I to put in controller,

$$P = 0.0001534$$

$$I = 0.06506$$

4.7 CHAPTER SUMMARY

22 The design and implementation of the PI controller for the boost converter was shown in this chapter, and the analysis of the nonlinear dynamics which can influence the converter performance was shown. Closed loop control of the output voltage for keeping the output voltage as stable and regulated as possible under the changing operating conditions like load disturbance, input voltage variations and parameter variations was discussed. The contribution of PI controller to the stabilization of a converter, the transient response, and its capability to better regulate the voltage was fully explained. The working principles of proportional and integral control actions were discussed to get an idea of how the PI controller minimizes the error between the reference voltage and the actual output voltage. The proportional action has been demonstrated to increase responsiveness and decrease rise time, whilst the integral action has been found to minimise steady state errors and provide an enhanced accuracy of long-term voltage regulation. The importance of tuning the parameters of the PI controller to ensure stability of the converter operation and good dynamic performance was also emphasized. In addition the Ziegler–Nichols tuning technique for determining appropriate proportional and integral gains of the controller was explained. It was provided a systematic and practical method to determine the controller parameters based on the dynamics of the system. Tuned to achieve stable operation of the converter, setting up the PI parameters assisted in reducing settling time and output voltage tracking errors. The chapter also had an introduction to nonlinear dynamics including saturation and dead-zone characteristics, as well as PI controller design. The linearity properties of those nonlinearities have been explained in practical converter systems and the effect on the operation, transient response and voltage regulation of the converter. Saturation nonlinearity has been used to give a limited duty cycle within realistic operating ranges of the machine and dead-zone nonlinearity has been added to show "no control" regions within the range of small control signals for the machine. In general, the chapter provided theoretical and practical background of implementing closed-loop control for the boost converter in a nonlinear operating condition. The concepts presented in this chapter are further applied in the subsequent chapter to perform MATLAB/Simulink simulation, transient response and performance evaluation of the PI controlled boost converter system.

44

CHAPTER 5

NONLINEAR DYNAMICS

5.1 INTRODUCTION

Taking into account switching actions, component constraints, and physical restrictions of semiconductor devices and control systems, the response of a practical power electronic system is not always exactly linear in boost converter operation. Ideal mathematical models are very helpful for simple analysis and controller design, but real converter system can always be affected by nonlinearities that will cause problems in system stability, transient response, ripple content, and overall performance. Hence, under practical operating conditions, the analysis of nonlinear dynamics becomes important in the understanding of realistic behavior of boost converter. Switching device limitations, duty cycle limits, dead-zone regions, actuator saturation, sensor nonlinearities, and parameter variations are the major causes of nonlinear dynamics in a boost converter. These non-linear effects can have a large impact, particularly when load rapidly changes, on start up, or when the input to the control signals changes significantly. Inaccuracies caused by ignoring the nonlinearities while analyzing the system are likely to cause the converter behavior to deviate from the expected theoretical behavior, leading to an inaccurate controller behavior and reduced system reliability. Saturation nonlinearity is one of the important nonlinear effects taken into consideration in this study. For practical converters, the duty cycle of the switching signal can not be expanded or reduced beyond any physical limits since the semiconductor switches can only handle a certain range of duty cycle. The saturation nonlinearity is added to limit duty cycle into safe operating limits and avoid overly large control action[56]. This restriction will reduce the risk of over-driving switching devices and help to assure operational safety. Saturation however, also brings in nonlinear behavior of the system which can impact transient response and converter stability when faced with large disturbances. Dead-zone nonlinearity is another important nonlinear characteristic studied in this work. A dead zone is a zone of control signals that has no measurable impact on the output control signals. In real systems, this phenomenon is frequently seen when switching thresholds, actuator non-linearity, device limitation or hardware restrictions are involved. Dead-zone nonlinearity can cause a loss of sensitivity in the controller and cause slow response of

the controller to small changes in the input signal in boost converter. This means that dead zones should include in the analysis of a converter to represent real converter operation more accurately. The study of nonlinear dynamics is important because in many modern systems of power electronics, operating loads are variable and the environment is uncertain, and the assumption of ideal linear systems is not adequate. The model for the converter is nonlinear, so that the practical limits and the dynamics of the system could be examined more realistically.

5.2 NONLINEARITIES OF BOOST CONVERTER

The actual form of the boost converter is not a true voltage gain function, however, due to such things as switching devices, physical component size restrictions and limitations in the control system. Ideal mathematical models can be used for basic analysis and controller design, however real converter systems are always subject to some nonlinear characteristics which will influence the steady state and dynamic performance of the converter. Under load variations, switching transitions, start and large disturbances these nonlinear effects play a more important role. The essential source of the nonlinear operation of a boost converter is the switching action of the semiconductors devices and hardware constraints. Due to these dis-linearities, the converter response may not be as theoretical as it was expected to be. Nonlinear effects can affect significant performance characteristics like output voltage regulation, transient response, settling time, ripple content, and system stability. In this research work, nonlinear dynamics are injected to the converter model to enable the analysis of the boost converter in a more realistic manner. To gain insight into operating conditions and control system limitations, including nonlinear features in the simulation would be beneficial. The nonlinear model can also more effectively show the robustness and effectiveness of the PI controller with different operating conditions. Saturation nonlinearity and dead-zone nonlinearity are two significant nonlinearities that are taken into account for the simulation and performance analysis of the closed-loop boost converter system in this work. The operating characteristics and effect on the converter response are different for both nonlinearities. The detailed explanation, functioning and effects on converter performance are presented in the subsequent sections.

97

5.3 SATURATION DYNAMICS

Nonlinear saturation behaviour is the behaviour of control systems in which the controller output is bounded by fixed maximum and minimum values. In real systems, electronic devices and actuators are not able to create an infinite amount of output since all physical elements have an operating range. Hence, if the control signal produced by the controller is trying to go out of these limits the saturation block will only allow the output to go to the maximum or minimum allowed value. This brings the overall system response to a nonlinear response. Saturation dynamics is normally related to duty cycle limitation of the switching device in boost converters. Semiconductor switches are limited to a range of switching and the duty cycle has a maximum and minimum value which can't be exceeded or negative. During large disturbances or transient periods the controller will try to produce a control signal outside of these limits and the duty ratio will not be increased or decreased beyond these limits by virtue of the saturation mechanism. The converter will thus operate within safe limits preventing unstable conditions. It is necessary to consider the saturation effects when analysing a converter since in a practical converter system there are always switch, actuator and amplifier saturation limitations and control circuit limitations. The lack of the following is considered to cause unrealistic simulation results and inaccurate prediction of converter performance. Thus, saturation modelling makes it possible to model the actual converter behaviour more realistically under real operating conditions. One of the main benefits of saturation nonlinearity is that the converter components are not subject to over actuating. The PI controller will try to produce very large control signals when there is a sudden load change or a large voltage error, thus quickly returning the output voltage to the desired value. Such excessive control action can result in switching stress, overheating, instability or even failure of semiconductor devices if there is no saturation limitation. These problems are eliminated by the use of saturation dynamics, which keep the output of the controller within limits. Saturation also has an impact on the dynamic characteristics of the converter, however. The controller output is limited under some modes of operation so the converter might respond slower and the transient response may be nonlinear. Saturation could cause extended settling times, overshoot or influence the performance of voltage regulation in large disturbances. So appropriate tuning of the controller is critical in order to reduce the impact of saturation and to reduce the impact on converter stability. In this research effort the saturation nonlinearity of the boost converter is modeled in closed loop with PI control

and is studied on its impact on the converter performance. The saturation block restricts the duty cycle to practical operating limits, and investigates the converter response in realistic nonlinear operating conditions. When saturation dynamics are considered in the converter system, the simulation analysis can be used to evaluate the stability, transient response and voltage regulation capability of the system.

- **Saturation Nonlinearity:** When the control signal reaches a predefined threshold, the output is limited, resulting in a nonlinear effect rather than a linear proportional response.
- **Purpose in Control:** Saturation protects actuators from damage due to over-driving and helps stabilize the system by preventing excessive control commands, especially when a PI controller produces large outputs under large error conditions.
- **Mathematical Representation:** The nonlinear saturation can be described as:

$$D_{sat}(t) = \begin{cases} 0.88, & \text{if } D(t) > 0.88 \\ D(t), & \text{if } 0 \leq D(t) \leq 0.88 \\ 0, & \text{if } D(t) < 0 \end{cases}$$

where $D(t)$ is the calculated duty cycle from the controller, and $D_{sat}(t)$ is the saturated output applied to the power switch.

5.4 DEAD-ZONE DYNAMICS

A type of nonlinear behavior in which the system only responds to certain ranges of small inputs near zero is called a dead-zone nonlinearity. That is, when this input signal is within a specified range of values called the dead-zone region, then the system is not responding to these small values. With the input signal below the dead-zone limit, the system does not start to provide an effective response. It is a nonlinearity frequently seen in many practical control systems and power electronic devices because of physical constraints of the devices and hardware components. Dead-zone behavior can be induced by any of the following reasons in boost converter systems: switching thresholds, semiconductor device characteristics, sensor insensitivity, actuator limitations and control hardware constraints. The low power levels of switching device activation and/or

noticeable changes in the converter operation may require small control signals from the controller. For this reason, if the input control signal is slightly lower than the dead-zone limit, the system will not react to the signal until its value reaches the dead-zone limit. The converter system has a large dead-zone nonlinearity, which has a significant impact on the dynamic performance. The converter is unable to respond to small input signals for the region between the dead-zone region, which could cause delayed response, sluggish behavior or less sensitivity to small disturbances. This may be detrimental in some way to the controller's ability to regulate voltage precisely, particularly at light loads or small signal changes. In practical systems where the use of dead-zones is of concern, actual electronic devices seldom exhibit a linear operation. Ideal systems: Small changes in the control signal result in proportional changes to the output. But practical converters are characterized by certain physical and electrical restrictions which mean that the change in the response of the converter is not immediate when very small control inputs are applied to the converter. By adopting the dead-zone, the dead-zone condition will be included into the model of converter and hence the operation condition of the converter will be better simulated.

Among the practical benefits of dead-zone, is the ability to avoid unwanted switching due to noise or very small changes in the control signal. The dead-zone region can suppress unnecessary switching and enhance noise immunity of a system by oversimplifying the variations in input. If the dead-zone width is too large, however, the width can negatively affect the performance of the converter by decreasing the accuracy of the voltage control and increasing the converter's response time.

The impact of the dead zone nonlinearity is more pronounced in transient operation, when the unit starts up and under sudden load changes. In these cases, the controller could produce a small signal to control the system, but this signal would not be enough to actually change the output until it is beyond the dead-zone. This makes the response of the converter slower than a linear ideal system.

The model of closed loop PI-controlled boost converter with the inclusion of dead zone nonlinearity is given in this research work to study its effect on the system performance. The use of dead-zone dynamics enables real-life non-linear operating conditions to be faithfully simulated, such as providing an evaluation of the converter stability, transient characteristics, voltage regulation performance and controller effectiveness. This

simulation analysis assists in the comprehension of the impact of dead-zone properties on the converter operation, and the overall system performance of the converter in a real-life application.

- The dead zone represents a range of inputs $[D_{min}, D_{max}]$ where the output is inactive.
- Only when the input exceeds this range does the system respond proportionally.
- Common in real systems due to mechanical play, actuator limits, or sensor insensitivity.

Purpose in control: In a control system, a dead-zone nonlinearity models the range of input signals that produce no output response due to physical limitations of actuators, sensors, or switches. It prevents the system from reacting to very small inputs or noise, improving stability and avoiding unnecessary control actions.

Mathematical Representation: The nonlinear dead zone can be described as

$$D(t) = \begin{cases} 0.88, & \text{if } u(t) \geq 0.88 \\ D(t), & \text{if } 0 < u(t) < 0.88 \\ 0, & \text{if } u(t) \leq 0 \end{cases}$$

Where the controller output (PI output) be $u(t)$, and the duty ratio be $D(t)$.

5.5 CHAPTER SUMMARY

This chapter discussed in detail the study and analysis of nonlinear dynamics of the boost converter system. Even though the converter system is a nominally linear system, practical versions exhibit nonidealities associated with switching devices, actuator limits, semiconductor constraints and hardware nonidealities. Hence, the need to take into account the nonlinear effects to get the accurate performance of the converter and behavior of the system under practical operating conditions. The chapter noted that in order to model the actual dynamic response of a boost converter system, non-ideal linear models are necessary. The principal emphasis of the chapter was on two major nonlinearities included in the converter model; specifically on saturation nonlinearity and dead-zone nonlinearity. The phenomenon of saturation dynamics was talked about as a nonlinear phenomenon, where the output of the controller, or its duty cycle is limited to

predetermined upper and lower operating bounds. As switching devices in practical boost converters are subject to physical limits, duty ratio limits must be imposed within these limits and as such must involve saturation. The chapter described the application of saturation to prevent excessive, damaging control action, switching stress and instability during large disturbances or sudden load variations in converter components. Concurrently, the effects of saturation on transient response, settling time and system performance was also emphasized. The chapter also examined the dead zone nonlinearity, which is an area in which small control signals do not produce any output response. The above behavior is nonlinear because of the presence of switching thresholds, insensitivities to the actuators and hardware constraints in actual systems.

The impact of the dynamic behaviour of the dead zone on the sensitivity, response speed and the ability to adjust the voltage of the converter has been described. When operating under small signal variations, it was observed that this dead zone adversely impacted delay in corrective action and slow response in the system. Besides, chapter highlighted the need for analysing and simulating converters based on nonlinear dynamics. A model has been built that includes nonlinearities, which allows a better idea of how the converter operates than provided by ideal models.

These aspects can be taken into account to capture the practical constraints on converter, the dead zone phenomenon and the dynamics of the control system for various operating conditions with good accuracy. The theory for this nonlinear closed loop boost converter PI controlled system has been set in this chapter with the main following conclusions: The nonlinear models developed in this chapter are also applied to simulation studies on the converter stability, transient responses, voltage regulation capability, ripple characteristics and overall system performance under realistic nonlinear operating conditions. The concepts discussed in this chapter also provide a basis for future development of advanced nonlinear and intelligent control strategies for power electronic converters.

CHAPTER 6

SIMULATION & PERFORMANCE ANALYSIS

6.1 INTRODUCTION

The process of power electronic system design needs to be supported by simulation and a performance analysis, as simulation can validate the theoretical model, modelling of a controller, and/or performance under different operating conditions. Mathematical modelling and controller design give the theoretical basis to the operation of the system in boost converter system, but the simulation analysis is required to investigate the validity that the proposed controller design is effective in practice or not. The dynamic response, stability, voltage regulating ability and non-linearity characteristics of the converter can be studied in detail using the simulation technique without any immediate implementation of the hardware. So, simulation can give a platform which is safe, flexible, accurate and cost-effective to evaluate the converter performance before its practical realization. With practical converter systems, various factors like load disturbances, switching effects, non-linearity and parameter variations affect the operation of the converter. The actual system response will be different due to these factors from the ideal theoretical response. Thus, simulation analysis is important to investigate the converter's operation under realistic conditions and to ensure that the designed controller can ensure stable and efficient operation. The matrix lab is selected as the simulation platform in this research work to implement and analyse the closed-loop boost converter system controlled by PI controller. Matrix lab is very popular in power electronics and control system applications because the environment can be used efficiently to model dynamic systems, implement control algorithms, analyse transient behaviour and observe the behaviour of the system as it operates under a range of different conditions. All the required circuits for boost converter, PI controller, nonlinear blocks, PWM switching and load conditions for system analysis are incorporated in the simulation model developed in this work. The main aim of the simulation study is to assess the performance of the proposed PI controlled boost converter under the non-linear operating conditions. The effect of saturation and dead-zone nonlinearities on converter stability, transient response and voltage regulation capability are explored and understood through simulation analysis. There are always physical constraints and nonlinear

constraints operating in a practical converter system making it more realistic to incorporate nonlinear dynamics into the simulation models of the converter system. The key performance parameters of the simulation analysis are the output voltage response, rise time, settling time, overshoot, steady state error, voltage ripple, inductor current response, and disturbance rejection ability. The performance indicators are used to evaluate the PI controller's performance and its capability of stable operation for different load conditions and nonlinear operating conditions. Converter dynamical behavior is extensively analyzed to observe the swiftness and error response in the output voltage to the reference input voltage[56]. Saturation dynamics is also studied by simulation to explain its effect on the converter operation. This saturation nonlinearity will result in the controller output being limited to practical operating range limits, and consequently very little variation of duty cycle and placing no undue stress on the converter components. Similarly, dead-zone nonlinearity is dealt with for the analysis of the system response and converter sensitivity from small dead zone input signals. Because of these nonlinearities, the robustness and effect of the converter and also the controller performance can be evaluated in realistic practical scenarios. Another important objective of the simulation analysis is testing out the performance of the converter under different non-linearity conditions. The performance of the converter under influence of these nonlinearities is gained using transient response, ripple and voltage regulation analysis under saturation and dead zone condition. This analysis can be conducted to gather insights about the deficiency of the PI controller while operating in a nonlinear environment and, most importantly, their location. Also, simulation analysis provides extra detailed understanding of the controller / converter dynamics. It also can be used to check the correctness of the mathematical model and controller design developed in the previous chapters. The simulation results can be used in validating the theoretical concepts, and predicting the performance of the converter in its practical implementation.

6.2 WITH SATURATION NONLINEAR DYNAMICS

The observation of the closed loop PI controlled boost converter is simulated and analyzed by using the matrix lab software in this study in saturating nonlinear condition. Using matrix lab, you can develop a powerful and flexible simulation environment to model power electronic converters, and to employ control algorithms and to observe the operation of the power electronic system under various operating conditions. The

software you're using can accurately analyze the converter dynamics, controller response, switching behavior, and nonlinear effects—before you need to do it in hardware. The simulation model used here is obtained by implementing the boost converter with PI controller, PWM switching mechanism, feedback control loop and saturation nonlinear block.

The saturation nonlinear block is added in the control loop to take into account practical operating limits of the switching device and controller output. However, in a real converter system the duty cycle should not be allowed to cross a certain minimum and maximum limit since the semiconductor switches have a limited operating range. Thus, the saturation block restricts the output of the controller to within a specified range that will allow safe and realistic operation of a converter.

If the controller tries to send a signal outside of the boundaries at transient state or due to sudden disturbance the signal level is clamped using the saturation block within the limit. This reduces unnecessary switching instruction, keeps the converter elements from being overdriven and makes the operation of the system safer. Saturation dynamics can also help to simulate the more realistic converter characteristics than ideal linear models.

The developed simulation model in matrix lab provides a very detailed view of the important converter parameters like the output voltage, inductor current, transient response, settling time, overshoot, ripple content, system stability, etc. When the converter system has been made nonlinear by using saturation nonlinearity, then the effect of practical control limitations on the overall converter performance can be analyzed.

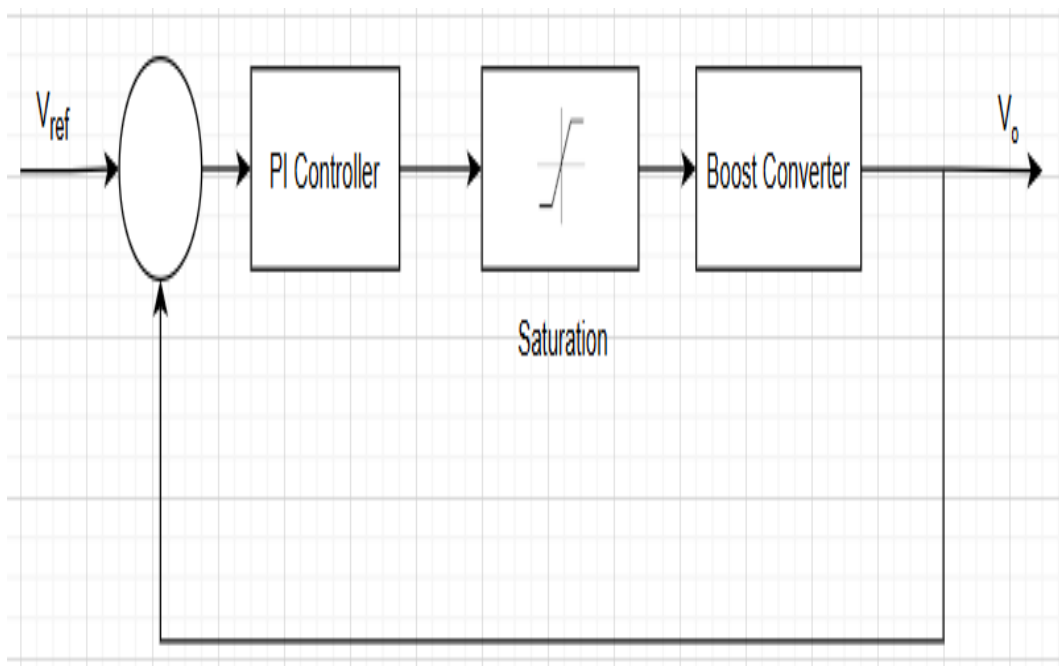

Fig. 6.1 Block diagram representation

25
18
45
74
37
110
73
40
1
60

Assuming the saturation nonlinear dynamics, a circuit diagram and detailed block diagram of the proposed closed loop system are shown in Fig.6.2. All of the system is designed and implemented in matrix lab to see the performance of the PI controlled boost converter in practical conditions with the presence of nonlinearity. The developed model primarily comprises of a reference voltage source, a summing junction, a PI controller, a saturation nonlinear block, a PWM switching mechanism, a boost converter, and a feedback path. The selected value of the reference voltage V_{ref} will be used in this research work is 400 V which is the desired output voltage of the boost converter. The aim of the closed loop control system is to keep the output voltage of the converter constant even if the load changes, or if the operating conditions change, or if there are non-linear effects or disturbances. The output voltage of the boost converter is sent to the input side via a feedback loop, and this voltage is always measured. This feedback signal is combined with the reference voltage at the summing junction, thus forming the error signal. The error signal is the difference between the output voltage of the converter & reference voltage that is set. This error signal is then passed onto the PI controller. Once the error has been processed, the PI controller generates the correct control signal necessary to control the output voltage of the converter. The integral part eliminates steady-state error and ensures that the steady-state voltage will be measured at the reference value, and the proportional part of the controller improves the transient response and speed of the system. A nonlinear saturation block is added to the control loop after the PI controller. This saturation block is used to ensure that the controller output can occur within an appropriate upper and lower operating range. Semiconductor switches can only function in a limited range and therefore the duty cycle of the switching device in the actual system of a boost converter must not exceed certain physical limits. Hence, the saturation nonlinear block reduces the duty cycle variation to a low level and keeps the converter from entering into unsafe operating conditions. The output of the saturation block is fed to the PWM generation unit, which generates the desired amount of gate pulses to control the MOSFET switch of the boost converter. The boost converter controls the output voltage according to the duty ratio applied by the controller, and works to transfer energy from the source to the load. The output voltage of the converter is continually measured and feedback to the control system, to make the operation a complete closed-loop. Saturation nonlinearities can be incorporated directly into the control loop to enable realistic analysis of the converter under practical operating conditions. An important aspect of the developed matrix lab model is its ability to analyse important performance

characteristics like output voltage response, transient behaviour, settling time, overshoot, ripple content and system stability. The simulation result acquired from this model offers insight into the efficiency of the controller voltage regulation under nonlinear saturation effects (NSE) even in the case of PI controller. A practical model for the boost converter with injection of PI control and saturation nonlinear dynamics is thus proposed, which enables the study of the converter's performance and the evaluation of the robustness of the control system under realistic nonlinear operating conditions.

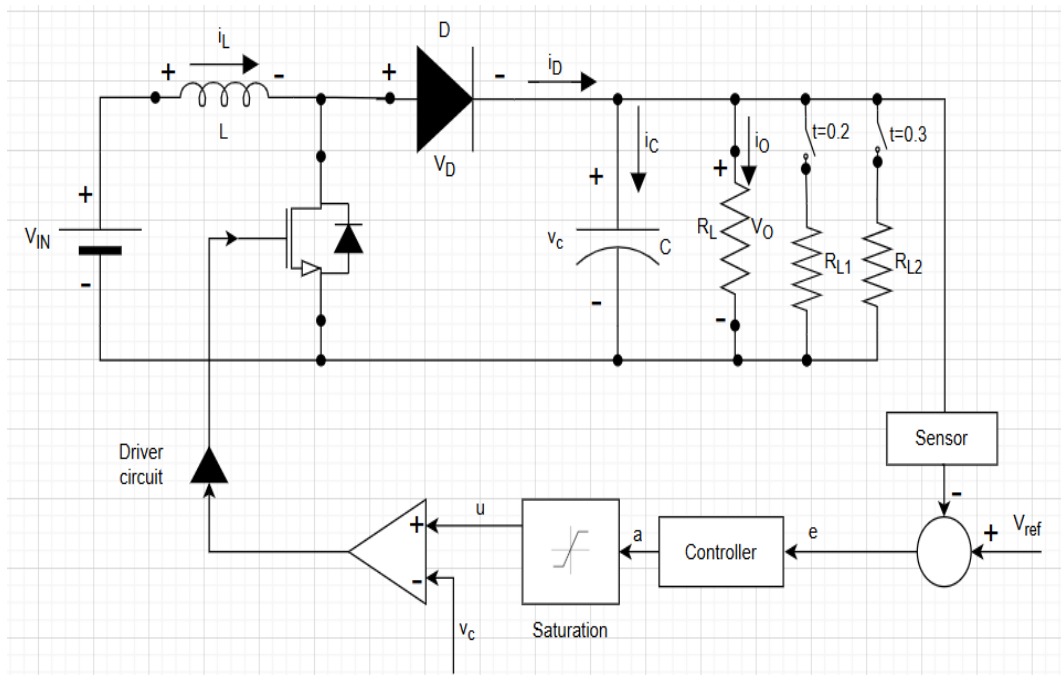

Fig. 6.2 Circuit/Block representation of closed-loop PI control of a Boost converter with Nonlinear saturation dynamics

Figure 6.3 represent the output waveform of the closed-loop PI-controlled DC-DC boost converter operating under saturation nonlinear dynamics. In this simulation model, the saturation block is incorporated within the control loop to limit the duty ratio of the converter within practical operating boundaries. For simulation purposes, the lower saturation limit is selected as 0, while the upper saturation limit is selected as 0.88. The limits are selected based on the practical operating range of the boost converter, and on the desired duty cycle for a 400 V output voltage given the source 4.5 V.

An important point about the lower limit is that it is set to 0 so that the duty cycle cannot be negative since negative duty ratios are a physical impossibility in the practical switching converter. In a similar fashion, upper limit of 0.88 ensures prevent overly large switching commands from being sent by the controller which can cause instability,

excessive switching stress or unsafe operating conditions. The duty cycle within this range ensures low voltage conversion power loss without compromising the switching characteristics.

In addition, the saturation nonlinear block is a useful representation of the actual nonlinearity in semiconductor switching devices encountered in actual converter systems. In transient conditions or sudden load changes, the PI controller might try to produce the duty ratio outside the range, to try to quickly regulate the output voltage. However, because of this saturation phenomenon, the control signal will be limited to within a certain specification causing the converter response to be nonlinear.

To investigate the converter's dynamic behaviour and robustness changes with different load conditions, the parallel connection of additional resistive loads is provided during a specific time interval. The first variation in the load occurs at $t=0.2$ seconds by adding an additional resistance to the load, while the second one occurs at $t=0.3$ seconds by adding another resistance to the load. The equivalent resistance to be considered is thus reduced and the actual load demand on the converter is increased by providing parallel resistance.

These load variations are intentional to enable the observation of the behavior of the PI-controlled boost converter with sudden load change under saturation nonlinear dynamics. The PI controller then processes this voltage error, and determines the duty cycle within the allowed values of saturation, to bring back the output voltage towards the desired value.

The capabilities of the proposed control system to keep the converter reasonably stable with nonlinear constraints and load disturbance are illustrated through the simulation waveform. Small transient deviations and settling effects occur in the transient response period while loads are switched, but the output voltage is regulated with the minimum possible steady state error with the use of a PI controller. The answer also suggests that the saturation nonlinearities do not destabilize the converter system, but instead result in reasonable operative limitations for the control action.

Thus, the simulation results shown in Figure 4 verify the effectiveness of the closed-loop PI-controlled boost converter under saturation nonlinear conditions and varying load environments. The analysis also demonstrates the robustness of the controller in

maintaining voltage regulation and stable system performance despite practical duty cycle limitations and dynamic load changes.

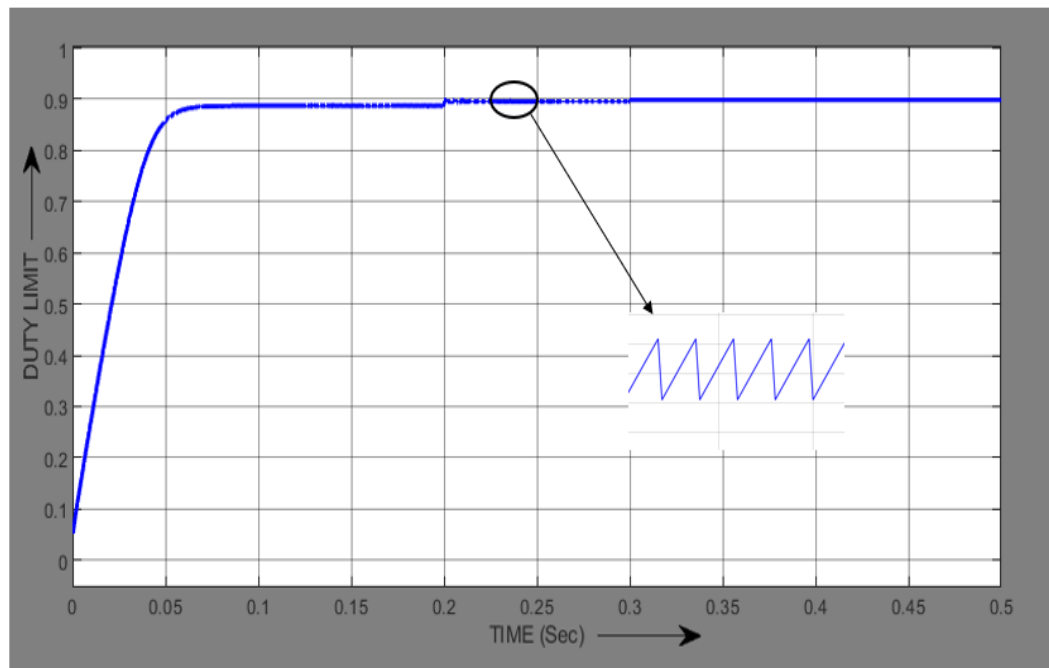

Fig. 6.3 Output of Saturation Dynamics

Figure 6.4 shows the IC waveform, which is also the inductor current waveform, of the closed-loop PI-controlled boost converter operating under saturation nonlinear dynamics. The waveform illustrates the behavior of the inductor current during normal operating conditions as well as under sudden load variations introduced at specific time intervals. Since the inductor is the main energy storage element of the boost converter, analysis of the inductor current is important for understanding converter stability, dynamic response, and energy transfer characteristics.

In this research work, load variations are introduced at $t=0.2$ seconds and $t=0.3$ seconds by connecting additional resistances in parallel with the primary load resistance. The addition of parallel loads decreases the equivalent load resistance and increases the overall power demand on the converter. As the load demand increases, the converter requires additional energy transfer from the source to maintain the desired output voltage level.

The waveform shows that during steady-state operation, the inductor current remains continuous and stable, indicating proper operation of the boost converter in CCM. Based on the continuity of the current, the value of the inductance selected and the switching

frequency is enough to ensure a smooth operation of the converter while keeping the current ripple low.

The converter is a saturated nonlinear dynamics operation, which helps to keep duty cycles within the set operating range. The controller is still able to accurately control the converter impact response and stable current response under transient conditions under these nonlinear constraints. Following the load change, which is disturbed by a sudden change, small transient oscillations, or ripple, The waveform further illustrates that the converter is successfully able to manage the dynamic load variations in a stable manner without getting un-stable.

Therefore, it can be claimed that the proposed PI-controlled boost converter system is robust and effective under the saturation nonlinear dynamics as shown in figure 6.4. To verify stable operation, energy transfer capability, and the stability under various-load-demand conditions of the converter's performance, the inductor current response is shown.

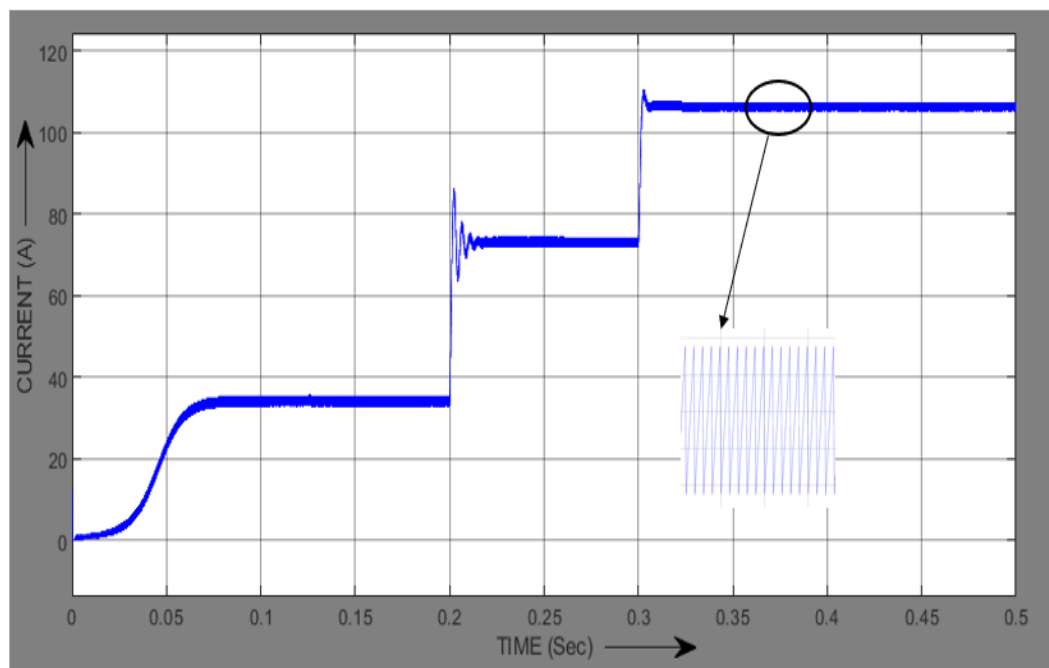

Fig. 6.4 Input Current (Input Inductor current)

Figure 6.5 shows the output voltage waveform of the closed-loop PI-controlled DC-DC boost converter working in saturation nonlinear regime. As the figure indicates, the converter can keep the output voltage near the set requirement of 400V in the above simulation period under the nonlinear operating constraints such as variable loads. The results obtained confirm the ability of the PI controller to control the output voltage of

the converter, even when the output load changes suddenly, while keeping the converter operating in a stable manner.

91 The waved form shows that the voltage ripple at the output is close to 1% - it could be deemed as operating within acceptable limits for practical boost converter applications. The output capacitor acts as a medium-frequency filter of the output voltage fluctuations resulting from high-frequency switching operation and helps keep the output voltage smooth and regulated. In the same way, Figure 5 and Figure 6 show at the same time both the voltage ripple and current ripple are within specifications, verifying that the converter is operating successfully in CCM.

Initially, (at $t = 0s$) only the main load resistance ($RL1$) is connected across the converter output. In this mode the converter is in steady state and maintains very low ripple content in the output voltage and very close to 400 V. The output voltage maintains steady value, which proves to be the closed-loop PI controlled system well operates. In this time period, the converter is only providing the base load, and the controller will ensure that the duty cycle is kept within the allowed saturation range in order to regulate the desired voltage.

Then at $t=0.2$ seconds a 106.67Ω load resistance ($RL1$) is added in parallel to the original load resistance. This added parallel resistance causes a decrease in the equivalent load resistance of the circuit and hence the entire load current requirements of the converter builds up. When the load demand suddenly rises, the output voltage has a transient response as a result of the sudden increase in the output current demand placed on the converter. This is seen as a small voltage dip and transient on the waveform.

63 The PI controller automatically detects the gap between output voltage & reference voltage using the feedback loop as soon as the load variation happens. Because of the error the controller changes the duty cycle of the switches to deliver extra power to the load and push the output voltage towards the reference of about 400V. As a result, the load current simultaneously increases, as more energy from the source is now required in order to provide the higher load demand. The converter can quickly and speedily return to steady state operation when subjected to a sudden disturbance, the transient response is acceptable and the ability to reject the disturbance is good.

76 Another parallel resistance (R_{L2}) of 280Ω , is then added across the load path at $t=0.3$ seconds. This further reduces the equivalent load resistance and hence the overall converter system power demand. Again, there is a temporary variation in the output voltage because of the sudden increase in the load's current. The response time is however short for the PI controller which changes the duty cycle within the saturation boundaries to assure output voltage regulation.

With multiple load variations the converter still is able to provide output voltage close to 400 V with very small steady-state error throughout the simulation. Some small oscillations and ripples are noticed right after the system picks up or drops load but it is stabilized rapidly without excessive overshoot or instability. This is the indication that a good PI controller tuning and the system is well controlled under dynamic load operation condition.

This behaviour is also borne out by the current in the inductor, displayed in figure 6.4. The more the loads are connected, the higher the current in the inductor will be, providing just as much as needed current to meet the added load. The current is maintained constant during the simulation process and it means that the converter is operating in a stable CCM mode during the simulation process. The proportion of ripple in current through the inductor stays in an acceptable range as well, which also shows that the inductor and switching frequency setting have been properly designed.

The important fact observed in the simulation is how the saturation nonlinearity affects converter dynamics. When executing transient operation, the 'duty cycle' requirement goes between some set 'low duty cycle' and 'high duty cycle' limits therefore, the controller can't allow unlimited control action during transients.

9 Overall, Figures 6.4 and 6.5 verify that the proposed closed-loop boost converter system performs effectively under saturation nonlinear dynamics and varying load conditions. The converter maintains stable output voltage, acceptable ripple content, continuous inductor current, and fast transient recovery even when subjected to sudden load disturbances. The simulation results confirm the effectiveness of the PI controller in regulating the converter output and demonstrate the practical applicability of the proposed system for stable and reliable power conversion applications.

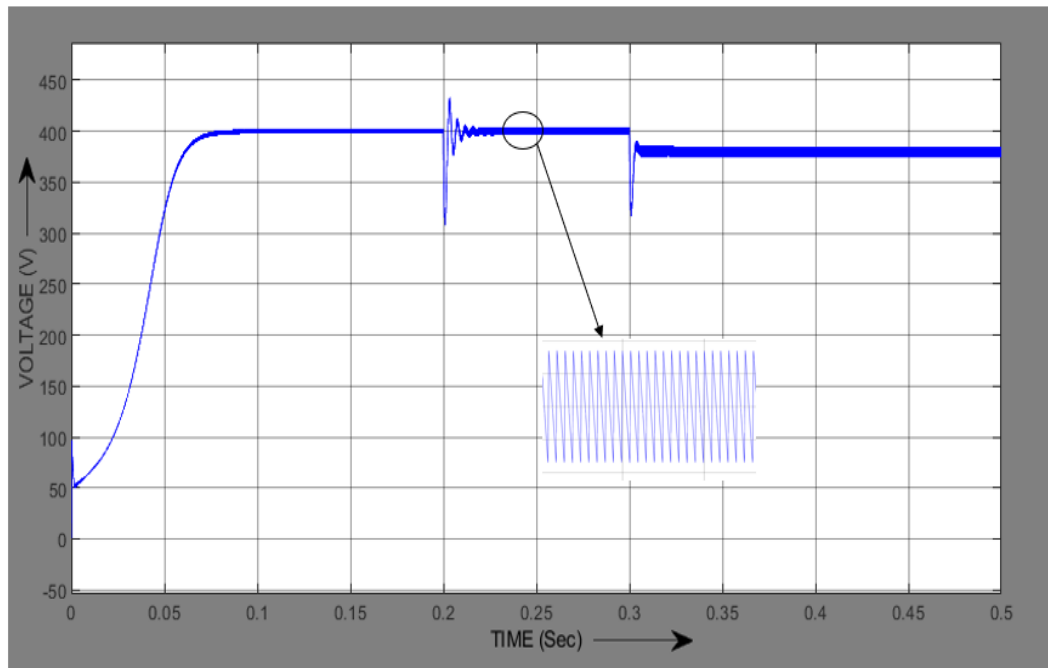

Fig. 6.5 Output Voltage (Volts)

6.3 WITH DEAD-ZONE NONLINEAR DYNAMICS

The block diagram of the closed-loop PI-controlled boost converter with dead-zone nonlinear dynamics is implemented in matrix lab to analyze the practical behavior of the converter under nonlinear operating conditions. In this model, the dead-zone nonlinear block is incorporated within the control loop along with the PI controller, PWM switching mechanism, feedback path, and boost converter system. The purpose of including the dead-zone nonlinearity is to represent practical situations where small control signals do not produce any effective response in the converter system. The controller output is then passed through the dead-zone nonlinear block before being applied to the PWM switching circuit.

The dead-zone block introduces a region in which small control signals are ignored by the system. As a result, very small variations in the controller output do not affect the switching operation of the converter until the signal exceeds the predefined dead-zone limit. This behavior represents practical limitations of switching devices, actuators, and control hardware used in real converter systems.

By having dead zone nonlinear dynamics, realistic analysis of converter response, transient operation, voltage regulation capability, and controller sensitivity under realistic operating conditions are possible. The simulation of this model is executed in latter stages

to investigate the effects of the characteristics of dead zone on output voltage response, current in the inductor, ripple content, and the overall system stability. The synthesized simulation results are useful for assessing the robustness and performance of the PI-controlled boost converter under the condition of the dead zone nonlinear operation.

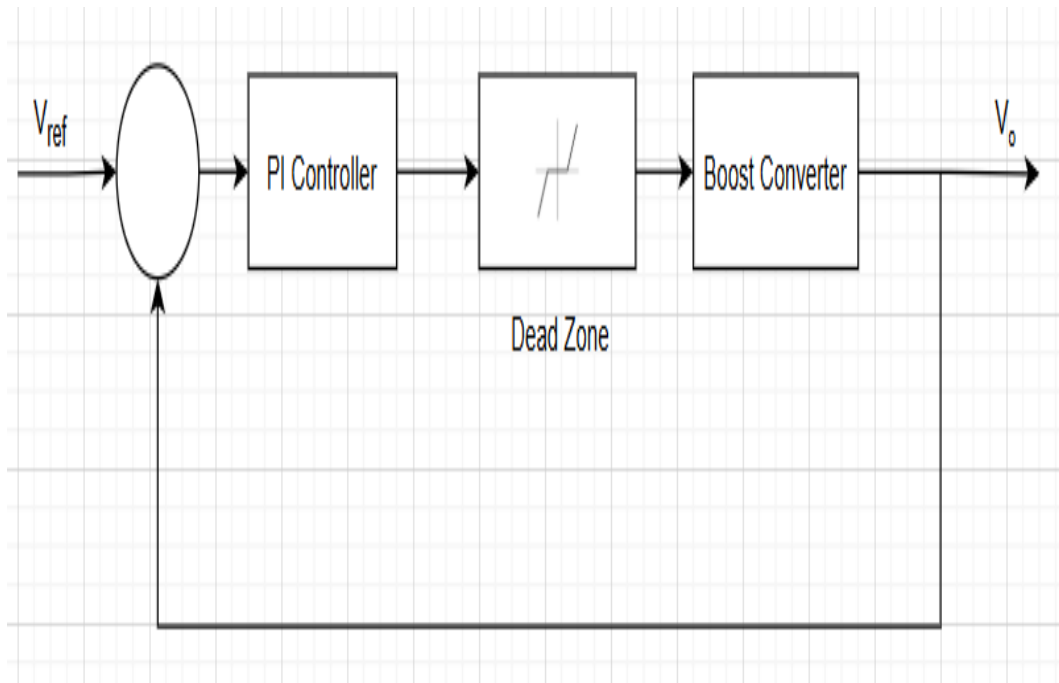

Fig. 6.6 Block diagram representation

Proposed the system with dead zone nonlinear dynamics circuit and detailed block diagram representation is shown in Figure 6.7. The entire system is realized in matrix lab which is used for analysing system performance under realistic nonlinear operation of the PI-controlled boost converter. The reference voltage source, summing junction, PI controller, dead zone nonlinear block, PWM switching circuit.

For this project, the reference voltage V_{ref} is assumed to be 400 V, the desired value of output voltage to be maintained by the boost converter. The initial goal of the closed loop control system is to keep this converter output voltage at this reference value despite the change of load. The first aim of the closed loop control system is to maintain the output voltage of the converter at this reference value for all dissimilar loads. The converter output voltage is fed back to the input side via the feedback loop, and is continuously checked.

The PI controller will adjust the set point of the switching device continuously based on the size of the error, so as to regulate the duty cycle of the switching device. A nonlinear

dead-zone block is added to the control loop in front of the PWM switching block following the PI controller. The inclusion of the dead zone nonlinearity is done in a realistic scenario in which small control signals do not give a precise response from the system. Due to these limitations switching devices and control hardware may fail to respond to very small input signals in real converter systems, with switching thresholds, insensitivity and actuator dead bands of the device being responsible. In the dead-zone region, therefore, if the output of the controller does not change significantly, the output will be said to be inside the dead-zone and will be ignored.

Dead zone nonlinear dynamics can be used to successfully treat the behavior of a converter under realistic operating conditions. The dead-zone effect produces a non-linear behavior of the converter, particularly in the presence of small-signal perturbations and load transients. This can impact slightly the response speed and voltage regulating performance of the converter.

Matrix lab model produced in this project can be used to investigate important performance parameters like output voltage response, transient characteristics, inductor current behavior, settling time and ripple content under dead-zone nonlinear conditions as well as stability of a system despite practical nonlinear limitations.

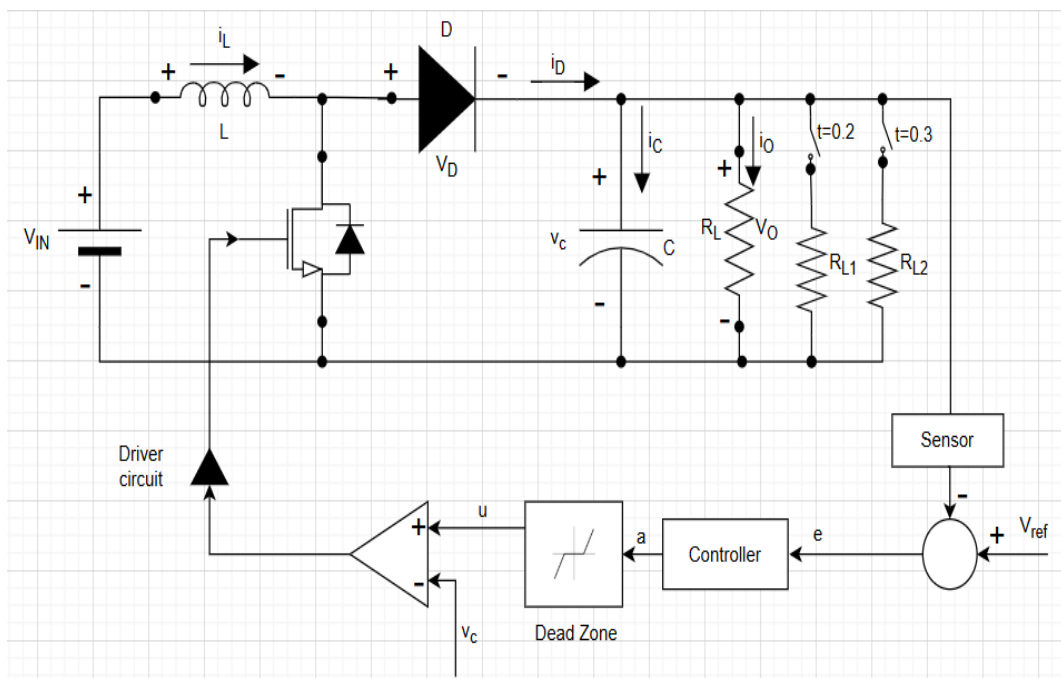

Fig. 6.7 Circuit/Block representation of closed-loop PI control of a DC-DC Boost converter with Nonlinear Dead Zone dynamics

Since the input voltage and input current conditions used for the dead-zone nonlinear model are identical to those used in the previous saturation nonlinear model, the corresponding input waveforms are not shown again. The same converter parameters, switching frequency, load conditions, and operating environment are maintained in order to provide a fair comparison between saturation and dead-zone nonlinear dynamics. Therefore, the analysis in this section mainly focuses on the output voltage response of the boost converter under dead-zone nonlinear conditions.

Figure 6.8 represents the output voltage waveform of the closed-loop PI-controlled boost converter operating with dead-zone nonlinear dynamics. In this simulation model, the dead-zone nonlinear block is incorporated within the control loop to represent practical situations where small control signals do not produce any effective response in the converter system. The dead-zone limits are selected according to the designed operating duty cycle range of the boost converter.

For this research work, the dead-zone lower limit or dead-zone starting point is selected as 0, while the dead-zone upper limit or dead-zone ending point is selected as 0.88. These limits are chosen based on the practical duty cycle operating range required to regulate the output voltage around the desired reference value of 400 V. The lower limit ensures that the duty ratio does not become negative, while the upper limit corresponds to the maximum allowable duty ratio for safe and stable converter operation.

Inside the dead-zone region, a slight change in the converter switching action cannot be achieved with a small change in the controller output. Switching thresholds and other practical system characteristics such as hardware insensitivity and device limit where very small control signals are not enough to be used for the switching device are a reflection of this behaviour. Because of this, small error signals produced by the PI controller may not cause it to respond instantaneously.

This output waveform (Fig 9) provides a representation of the action of the boost converter under these nonlinear dead zone conditions. Due to the dead-zone region, however, it may be noted that a slight delay or sluggishness may appear upon transient operation as compared to ideal linear operation. By this, the converter response to small disturbances becomes relatively slow when the disturbances are within the dead-zone

limits, which is signalled by the corrective signals being small. Overall voltage regulation is satisfactory and stable operation is successfully realized for this nonlinear constraint.

The simulation results have also shown that the dead-zone nonlinearity does not cause instability of the converter system. Rather, it offers a more realistic representation of realistic converter behaviour within hardware constraints and switching thresholds. The PI controller successfully overcomes the nonlinear effect and maintains the output voltage in acceptable operating regions.

Therefore, the effectiveness of the proposed closed-loop PI-controlled boost converter has been verified by Figure 6.8, which is a nonlinear dynamics characterized by dead zone. The result of simulation is the converter has a stable output voltage and satisfactory performance even when the practical dead-zone characteristics exist in the control system.

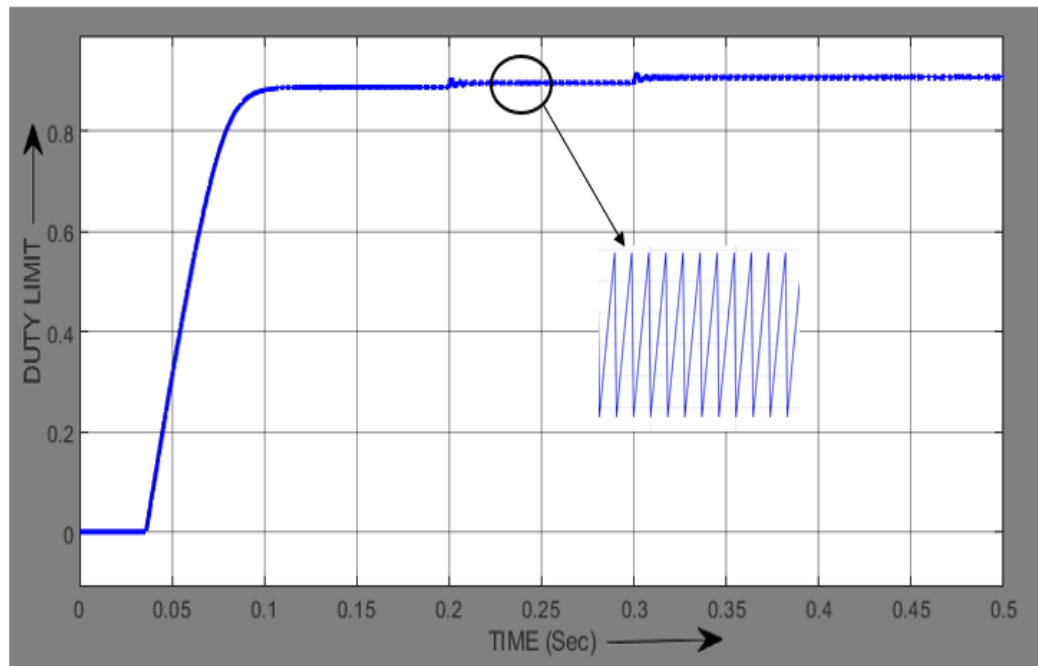

Fig. 6.8 Output of Dead Zone Dynamics

The closed loop PI controlled boost converter input current with dead zone nonlinear operation is shown in figure 6.9, which is also the inductor current waveform of the boost converter. The chart displays how the current changes in the inductor when it is operating in a steady state, and how the inductor current changes for various loads at varying times. The primary energy storage device in a boost converter, the inductor is therefore significant from an analysis viewpoint to gain insight into the converter stability, energy transfer capabilities and dynamic response to nonlinear operation.

In this research work load variations are introduced at time $t=0.2$ seconds and $t=0.3$ seconds by inserting load resistances in parallel with the load resistance. The parallel load adds to the combined resistance of the converter and the load it is connected to, thus increasing the power consumption of the load. A larger voltage output is required by the converter when the load demand goes up, thus introducing extra energy to keep the converter at 400 V output voltage.

The converter works at the initial operating condition that is the steady state with the stable and continuous inductor current. This is a continuous current behavior, showing the correct values for the inductance, frequency and controller parameters.

115 The converter has a sudden increase of current demand at $t=0.2s$ when the first additional parallel load is connected. Therefore, to convey more energy from the source to the load, the inductor current increases. In the PI control, feedback is used to detect the output voltage disturbance, and changing the switching duty cycle automatically adjusts to compensate for increased load demand.

125 In a similar manner, at the end of $t=0.3$ seconds another parallel resistance is added across the load that adds to the load's power demand to the converter. Thus, after the additional load current is added, the current flow through the inductor rises again to satisfy the extra load to get stable output voltage regulation. From the waveform of the conversion, it can be seen that the converter is able to follow these load changes without losing stability or discontinuous conduction mode.

Because the converter operates under dead-zone nonlinear dynamics, small control signals generated by the PI controller may initially remain ineffective within the dead-zone region. This may cause slight delay in the converter response during transient conditions. However, once the controller output exceeds the dead-zone threshold, the converter responds effectively and restores stable operating conditions. Despite this nonlinear behavior, the overall current response remains stable and controlled.

The waveform also indicates that the current ripple remains within acceptable limits throughout the simulation period. Small transient oscillations may appear immediately after the load variation due to sudden changes in power demand, but the system quickly stabilizes and settles to a new steady-state operating condition. This confirms proper

tuning of the PI controller and satisfactory performance of the boost converter under dead-zone nonlinear conditions.

Thus, Figure 6.9 verifies the effectiveness and robustness of the proposed closed-loop PI-controlled boost converter under dead-zone nonlinear dynamics and varying load conditions. The inductor current response demonstrates stable CCM operation, proper energy transfer capability, and successful adaptation of the converter to dynamic load variations while maintaining overall system stability and satisfactory performance.

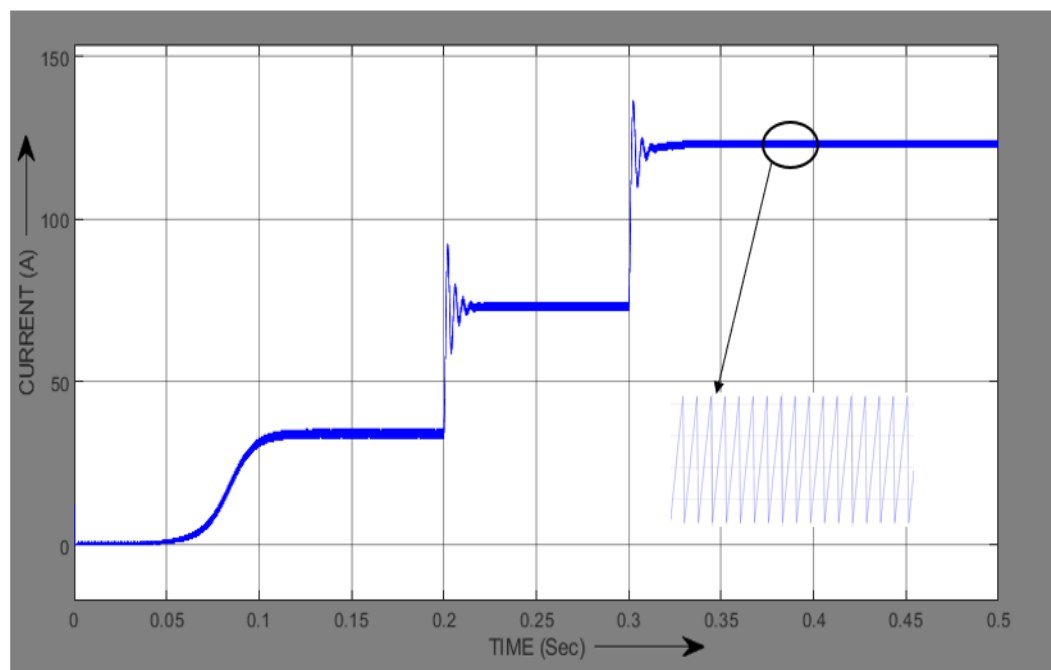

Fig. 6.9 Input Current (Input Inductor current)

46 The output voltage of the closed loop PI controlled boost converter is shown in Figure 6.10 when the converter is working in the dead zone nonlinear dynamics. The simulation results proved that the converter system proposed can properly control the output voltage close to the 400 V nominal value and with a ripple content of almost around 1%. The small ripple was seen in the wave form, which verify the efficiency of whole design of the converter, selection of passive circuit, switching frequency and suitable choice of parameter for PI controller. The output voltage is a constant during the simulation time, which reveals that the proposed system is able to maintain a satisfactory voltage regulation under the nonlinear operating condition during simulation.

99 The boost converter system is designed in this research work specifically for a regulated output voltage of 400 V with minimum voltage ripple through the system and stable transient performance. The simulation obtained proves that the proposed PI-controlled

converter is able to fulfill the design goals. The results show the output voltage waveform with the converter operating with dead zone non linearity in the control loop, maintaining proper voltage regulation and continuous operation whenever the load changes. However, when compared with the saturation nonlinear model discussed previously, the output waveform under dead-zone nonlinear dynamics exhibits relatively sluggish transient response. This behavior occurs because, within the dead-zone region, small control signals generated by the PI controller do not produce any effective response from the converter system. As a result, the controller cannot immediately correct small voltage deviations until the error signal exceeds the predefined dead-zone threshold. Consequently, the converter response becomes slightly slower during transient conditions and load disturbances compared to the saturation nonlinear model.

At the initial operating condition, that is at $t=0$ seconds, only the primary load resistance of 106.67Ω is connected across the converter output. Under this condition, the converter operates in steady state and maintains the output voltage close to 400 V with small ripple content. The inductor current and output voltage remain stable, indicating proper operation of the closed-loop PI-controlled system under dead-zone nonlinear conditions. During this interval, the converter supplies only the base load demand, and the PI controller maintains stable voltage regulation through continuous feedback control.

At $t=0.2$ seconds, an additional parallel resistance of 106.67Ω (R_{L1}) is connected across the existing load resistance. The addition of this parallel resistance reduces the equivalent load resistance and significantly increases the total load current demand on the converter. As the load suddenly increases, the output voltage initially experiences a transient dip due to the increased power requirement of the load.

The PI controller detects this change in the output voltage in the feedback path and tries to work around the disturbance by making the control action larger and changing the duty ratio of the switching. Due to the dead-zone nonlinearity of the control system, however, small signals of correction did not work until they became large enough to overcome the dead zone. In this case, the change of the converter is slower, compared with the saturation nonlinear model, during the transient time. The output voltage experiences a slight delay in recovery from this behavior in the waveform.

81 But, even with this slow response, the converter is able to bring the output voltage near its desired reference value within a short transient interval. The waveform shows that even under the dead-zone nonlinear condition, PI controller can still ensure the stable operation of the converter and provide the voltage regulation performance.

25 At $t=0.3$ seconds, another parallel resistance of 106.67Ω (RL2) is connected across the load. This in turn reduces the equivalent load resistance to further increase the converter system's overall power requirement. Consequently the converter once again suffers from a temporary disturbance in output voltage again as a result of the sudden rise in load current demand. The output voltage flattens out briefly and then the PI-controller sends a signal back to ensure that the voltage is brought back towards the set level.

In this case the dead-zone nonlinearity again affects the transients response of the converter. The switching operation is comparatively slower in the small controller output case with respect to the saturation nonlinear case since the small output does not directly influence the switching operation. Beyond that, when the control signal is outside the dead zone the converter performs a duty cycle adjustment and re-establishes stable operation.

Even with various load changes, the converter output voltage is kept close to 400 V with a tolerable amount of load ripple and a minimum steady-state error, showing a very stable performance from the converter. Slightly more obvious transient oscillations and delayed recovery occur under dead-zone dynamics, but the overall dynamics remain stable during the simulation time. The converter has no instability and the overshoot in the response to the dynamic load changes is not large.

The low ripple as seen on the waveform is further evidence of proper operation of the output capacitor and good filtering of switching ripple. Even with the nonlinear limits imposed by the dead-zone block, the PI controller is able to remain in stable operation and continuously regulate.

23 The results in Figure 6.10 confirm that the proposed closed-loop PI-controlled boost converter system operates satisfactorily under the two conditions namely under nonlinear dynamics due to dead-zone characteristics and under different load conditions. From the simulation results, it is shown that the small ripple content of the designed system is also

successfully producing the desired output voltage of 400V while keeping the converter stable with loads changes. It is also interesting to compare the behavior to saturation to emphasize the role of dead zone effects on converter transient response and voltage regulation.

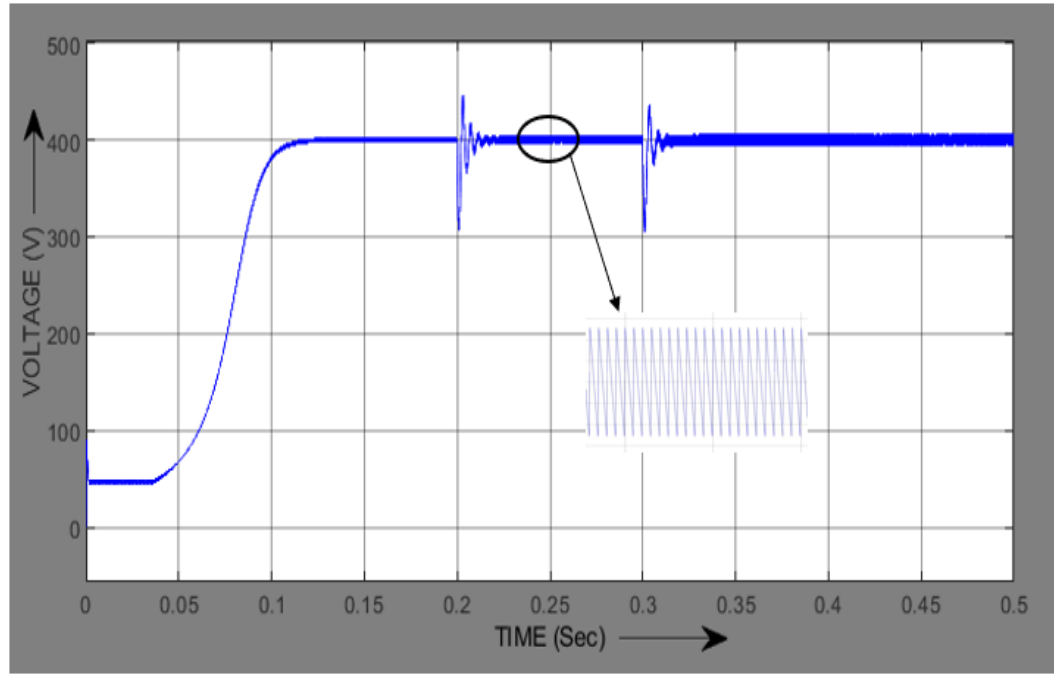

Fig. 6.10 Output Voltage (Volts)

6.4 CHAPTER SUMMARY

In this chapter, the simulation and performance analysis of the closed-loop PI-controlled boost converter was introduced under nonlinear active (PWM) and passive (d(current) modes of operation in matrix lab. The simulation study was conducted to verify the mathematical modelling, controller design and nonlinear dynamics of last chapters. The simulation model was developed and consists of the following elements: boost converter, PI controller, PWM switching mechanism, the feedback loop, and nonlinear blocks (saturation, dead-zone dynamics). The success of the simulation results was used to provide valuable insight into the operating characteristics of the converter in various nonlinear operating conditions and different operating loads.

The chapter mainly addressed the dynamic response & voltage regulation capability of the proposed converter system for two different nonlinear situations, namely the saturation nonlinearity and the dead-zone nonlinearity. In both cases, the converter should operate at an output voltage of about 400 V, have a minimum ripple and stable operation.

During the saturation nonlinear, the duty cycle limits of the controller were limited to practically between 0 and 0.88. The simulation results indicated that the converter was able to hold the operating state as well as DC output voltage when a sudden load varying condition has been applied to the converter at different time periods. The acceptable output voltage ripple and acceptable inductor current ripple were achieved, thus the control converter design and tuning were done correctly. The capability to resist the disturbance was also satisfactory, and the transient response showed good results in the saturation nonlinear model.

In the same way, performance of the converter was analyzed with dead zone nonlinear dynamics. The dead-zone block caused a dead zone in this case small control signals failed to drive the converter system. The simulation results were presented for output voltage which was close to 400V with a low values of ripple content that was almost 1%. In comparison with saturation dynamics, the dead-zone dynamics have a relatively slow time response for reach-able setpoints, with a time lag when the controller moves into the dead zone. The converter operated quite stable and had fairly good voltage regulation, even with this effect.

The effect of load variations on the performance of converter has been also investigated. The dynamics of this converter system were investigated by adding additional resistive loads in parallel at various time intervals. The simulation waveforms showed the PI controller was able to compensate for sudden load disturbances by varying the duty cycle of the switching device, and bringing the output voltage back to the desired reference value. The result of the Inductor current waveforms showed Continuous Conduction Mode (CCM) stable operation during the simulation time.

The simulation results overall validated the effectiveness and robustness of the proposed PI-controlled boost converter for practical nonlinear operating conditions. The designed system has been analyzed confirming stable control of the voltage, low ripple content, acceptable transient response and reliable operation characteristics under both the saturation and dead-zone nonlinear dynamics. These observations in the chapter give useful information about working performance of boost converter and justify the proposed theories in the whole project.

CHAPTER 7

CONCLUSION & FUTURE SCOPE

7.1 CONCLUSION

In this research work, detailed analysis, modelling, design of controller for closed-loop PI-controlled boost converter under nonlinear dynamic conditions and simulation have been presented. The study was primarily directed towards achieving better voltage regulation performance of the boost converter with the inclusion of practical nonlinearities such as saturation and dead zone effects in the designed control system. Because practical power electronic converters are always subject to switching restrictions, actuator limitations and nonlinear operating behavior, incorporation of these nonlinearities offered a more realistic picture of the actual power converter operation than ideal linear models.

The research began with the design and analysis of boost converter, which involved detailed discussion of the design process of the component, switching modes and working principle of boost converter. The main focus of the converter was to boost the input voltage to a regulated output voltage of 400 V without significant voltage ripple and without any operating instability. Appropriate converter parameters such as load resistance, capacitance, inductance and switching frequency were considered and the Continuous Conduction Mode (CCM) operation was obtained, allowing the converter to perform well.

Then, the boost converter was mathematically modeled to understand the dynamics of the system in different switching conditions. The operation of the converter has been studied for switch ON conditions and switch OFF conditions and with the fundamental electrical rules, the dynamic equations have been derived. Averaging technique was used to develop the mathematical model of the converter, which was the base for the design of the controller and simulation analysis. The model established a theory to pursue the research on converter stability, transient response and control system performance.

The integral action eliminated steady state inaccuracy and ensured voltage tracking, while the proportional action improved transient response and fast response. The controller

parameters were calculated using the Ziegler–Nichols tuning approach that yielded the correct proportional and integral values for the steady operation of the converter. Based on the results of the simulation, the PI controller was found to maintain the output voltage near the desired reference value under different operating conditions.

In this research effort, one of the significant things has been the introduction of nonlinear dynamics in the converter control. Two key nonlinearities, saturation and dead-zone dynamics, were added and studied in detail. Saturation nonlinearity was added to keep the controller output and duty cycle within reasonable bounds. This minimized switching activity and kept the converter safe to operate during transient loading and disturbance conditions. A nonlinearity was applied in the form of a "dead zone" to account for areas in which small control signals do not give an effective output signal from the system reflecting acceptable practical hardware limitations and switching thresholds.

The practical effect of these nonlinearities on the behaviour of the converters was illustrated by simulation analysis using the two programs of MATLAB/Simulink. The converter operated in a saturation nonlinear dynamics and had good saturated operating mode stability and acceptable transient response with a small amount of ripple in the output. A duty cycle of <0.88 within the designed operating range of 0-0.88 was achieved in the saturation block with good regulation of the output voltage around 400V. The PI controller was able to overcome load disturbance and re-establish the output voltage is quick after the transient disturbance.

The same was done in the case of dead-zone nonlinear dynamics. From the simulation results it is seen that the dead zone phenomenon caused relatively low speed of the transient response as a small output of the controller in the dead zone did not immediately act on the converter. This is a nonlinear operation but despite this, the output voltage of the converter was stable and it was able to keep the voltage around 400 V with almost below 1% ripple under all conditions. The PI controller was able to eliminate the dead-zone effect and achieve good voltage regulation performance in different load conditions.

An extra load variance analysis was done by adding more resistive loads in parallel, at different times in the simulation. The results showed that the closed-loop converter system proposed in this paper had excellent disturbance rejection ability and could stably work when the load parameters changed dynamically. The current through the inductor

was also shown as a continuous current during the simulation period, which is the indication of the stable CCM operation state of converter. satisfactory converter design and controller performance were ensured by not exceeding the voltage and current ripple contents within acceptable limits.

As comparison of the two types of nonlinear dynamic, saturation and dead-zone, provided important insight into the practical behavior of nonlinear converter systems, they are also analyzed in this section. The saturation model had a comparatively better transient response and control action, whereas the dead-zone model had slightly delayed transient response with reduced response to small control signal. However, for both nonlinear cases, the PI controller was able to stabilize the converter and keep the output voltage error within the required tolerance.

The overall findings of this research work confirm that a PI-based closed-loop control strategy along with the incorporation of nonlinear dynamics can yield significant and reliable performance of the boost converter applications. The desired output voltage regulation has been successfully obtained without any appreciable steady-state error with minimum transient response and minimum ripple content for minimum number of nonlinear constraints and stable operation under various load and nonlinear constraints. The study also confirmed the effect of practical non-linear kvp effects in converter analysis is more realistic and accurate in the evaluation of systems.

The proposed methodology presented in this thesis offers a complete methodology for implementing practical controller design and nonlinear analysis of a boost converter. The ideas and methodology presented in this work can be successfully implemented into some of the modern power electronic applications, which demand the power converter to be efficient, stable, have accurate voltage control, and to perform effectively with critical requirements of efficiency, stability, accurate voltage control, and reliable performance, including the renewable energy power electronics systems, solar photovoltaic systems, battery charging circuits, electric vehicle power electronics systems, power electronic systems of portable electronic devices, power electronics systems for industrial automation, and advanced power electronics systems for voltage control.

72 Finally, this study provides a good foundation for the future development of advanced control techniques for converters, which are nonlinear and intelligent. In the extremely nonlinear and uncertainty operating situation, future studies can use the adaptive control, fuzzy logic control, sliding mode control, neural network based control and model predictive control technique, etc., to improve the performance of the converter.

7.2 FUTURE SCOPE

66 The purpose of the research undertaken as part of the contents of this thesis was to analyse and implement a closed-loop PI-controlled boost converter under the following nonlinear operating conditions: saturation and dead-zone dynamics. The simulation results showed that the proposed control strategy was able to successfully track the output voltage under steady state and provide satisfactory transient response over a range of load conditions without any control performance degradation observed, demonstrating stable output voltage regulation, minimal steady state error, and good transient response. Though developed system is performing well yet still some efforts are needed for further improvement and extension of research to enhance the robustness, efficiency of the developed system, quick dynamic response and robust adaptability under realistic working conditions.

The advanced adaptive and intelligent control techniques are alternatives to the considered PI controller and are the important future scope of this research. The PI controller is easy to implement and can achieve satisfactory performance, but its performance could drop in conditions of high nonlinearity, parameter uncertainties and fast changing load disturbances.

It is noted that fuzzy logic control is an important and useful extension of this work, because: Fuzzy controllers produce results without the need of a proper mathematical model of the converter system; Fuzzy controllers can manage the non-linear behavior and parameter variations of the converter system. The fuzzy logic controllers offer better adaptability in uncertain operating condition, faster transient response and better disturbance rejection property, than conventional PI controllers.

In the same way, the sliding mode control will be applied for the future work to enhance the converter's robustness for nonlinear effects and external disturbance. Because of their

excellent stability properties, quick dynamic response and low sensitivity to parameter changes, sliding mode controllers are very efficient for nonlinear systems. Unknown constraints, such as sudden load changes, are of potential interest for the application of sliding mode control, where a significant improvement in converter stability can be obtained.

Another promising future direction is to include model predictive control (MPC) techniques in the boost converter system. Model predictive control (MPC) involves predictive algorithms and optimization techniques to decide on most appropriate control action over the prediction horizon under consideration. MPC can achieve improved transient response, a reduced overshoot, and better handling of the nonlinearities, like saturation and dead-zone effects. Predictive control strategies can also be used to enhance switching performance, and to decrease the ripple content in the converter system.

Future research could also include Artificial Intelligence/Machine Learning based control approaches. Under varying operating conditions, neural network controllers and intelligent optimization algorithms can be applied in automatic tuning of controller parameters. This intelligent control can enhance the adaptability, self-learning ability and the optimization of real-time performance of the converter.

Mainly based on a matrix lab simulation analysis, the present research work is conducted. While simulation is an effective way of understanding how a converter will behave, it is important for this behaviour to be verified with practical hardware implementation under actual operating conditions in order to simulate the results. For future work, a prototype of the laboratory can be developed by using power electronic devices like MOSFET, IGBT, DSI (digital signal processor)/microcontroller or FPGA (field programmable gate arrays) based control platform.

Experimental validation can provide deeper understanding of practical issues such as switching losses, thermal effects, electromagnetic interference (EMI), sensor noise, gate driver limitations, and component nonidealities that may not be fully represented in simulation models. Real-time testing can also help analyze converter reliability, efficiency, and controller effectiveness under practical operating environments.

29 Future research may additionally focus on efficiency optimization of the converter system. Different soft-switching techniques, optimized PWM strategies, and high-efficiency semiconductor devices such as SiC and GaN-based switches can be investigated to reduce switching losses and improve overall converter efficiency. Thermal management techniques and heat sink optimization may also be explored for high-power applications.

Since renewable energy sources generally produce variable DC voltage, advanced boost converter systems with robust nonlinear control strategies can play an important role in maintaining stable voltage regulation and improving energy conversion efficiency.

Further studies may also include analysis of additional nonlinear effects such as hysteresis, switching delays, parasitic components, quantization effects, and time-delay dynamics to achieve even more realistic converter modelling. Stability analysis using bifurcation theory, chaos analysis, and nonlinear state-space techniques may provide deeper insight into complex converter behavior under extreme operating conditions.

Overall, this research work provides a strong foundation for future development of advanced nonlinear control strategies and practical implementation of boost converter systems. The concepts developed in this thesis can be further extended to achieve improved efficiency, enhanced robustness, intelligent control capability, and reliable performance for modern power electronic applications operating under highly dynamic and nonlinear environments.

REFERENCES

1. O. Rabiaa, B. H. Mouna, S. Lassaad, F. Aymen and A. Aicha, "Cascade Control Loop of DC-DC Boost Converter Using PI Controller," International Symposium on Advanced Electrical and Communication Technologies (ISAECT), Rabat, Morocco, pp. 1-5, 2018.
2. Dave, M.R. and Dave, K.C., Analysis of boost converter using PI control algorithms. International Journal of Engineering Trends and Technology, 3(2), pp.71-73, 2012.
3. Design and Simulation of Closed Loop Proportional Integral (PI) Controlled Boost Converter and 3-phase Inverter for Photovoltaic (PV) Applications. Al-Khwarizmi Engineering Journal, 15(1), 10-22, 2019.
4. P. Lorenzetti and G. Weiss, "Saturating PI Control of Stable Nonlinear Systems Using Singular Perturbations," in IEEE Transactions on Automatic Control, vol. 68, no. 2, pp. 867-882, Feb. 2023,
5. Aguilar-Ibañez, C., Mendoza-Mendoza, J. A., Suarez-Castanon, M. S., & Davila, J. A nonlinear robust PI controller for an uncertain system. International Journal of Control, 87(5), 1094–1102, 2014.
6. Nagarajan, R., Chandramohan, J., Sathishkumar, S., Anantharaj, S., Jayakumar, G., Visnukumar, M. and Viswanathan, R. Implementation of PI controller for boost converter in PV system. International Journal of Advanced Research in Management, Architecture, Technology and Engineering (IJARMATE), 11, pp.6-10, 2016.
7. J. Zhou, C. Wen and Y. Zhang, "Adaptive output control of nonlinear systems with uncertain dead-zone nonlinearity," in IEEE Transactions on Automatic Control, vol. 51, no. 3, pp. 504-511, March 2006.
8. N. Nasrullah, B. Sujanarko and B. S. Kaloko, "Effective Model of Boost Converter Based on Simulink MATLAB," 2024 IEEE 2nd International Conference on Electrical Engineering, Computer and Information Technology (ICEECIT), Jember, Indonesia, pp. 147-152, 2024.
9. J. -I. Corcau and L. Dinca, "A new mathematical model for the continuous conduction mode of the boost converter," 2016 International Symposium on Power Electronics, Electrical Drives, Automation and Motion (SPEEDAM), Capri, Italy, pp. 797-802, 2016.

10. S. Hiti and D. Borojevic, "Robust nonlinear control for boost converter," in *IEEE Transactions on Power Electronics*, vol. 10, no. 6, pp. 651-658, Nov. 1995.
11. O. Rabiaa, B. H. Mouna, S. Lassaad, F. Aymen and A. Aicha, "Cascade Control Loop of DC-DC Boost Converter Using PI Controller," 2018 International Symposium on Advanced Electrical and Communication Technologies (ISAECT), Rabat, Morocco, 2018, pp. 1-5.
12. K. Vishnu, R. K. Nema and A. Ojha, "Boost Converter with Fuzzy Logic, PI Controller and Sliding Mode Control for a Variable Source Input," 2020 International Conference on Computational Intelligence for Smart Power System and Sustainable Energy (CISPSSE), Keonjhar, India, 2020, pp. 1-5.
13. M. J. Mamghani, S. Teymoori, N. Eskandarian and S. Sabzevari, "A Novel Optimal PI Controller Based DC/DC Boost Converter Application," 2022 IEEE 13th International Symposium on Power Electronics for Distributed Generation Systems (PEDG), Kiel, Germany, 2022, pp. 1-5.
14. A. Belkheir, B. Amar, B. Ouahid, B. Rabhi, Z. Laid and B. M. Fouad, "Modeling and control of an interleaved boost DC-DC converter applied for PEM fuel cell," 2021 IEEE 1st International Maghreb Meeting of the Conference on Sciences and Techniques of Automatic Control and Computer Engineering MI-STA, Tripoli, Libya, 2021.
15. I. A. Ayad, E. E. Warraki and A. Nouri, "A Self-Tuning Fuzzy PI Controller for Three-Level Boost Converter," 2018 6th International Renewable and Sustainable Energy Conference (IRSEC), Rabat, Morocco, 2018, pp. 1-6.
16. F. A. Samman, N. Maulana and R. S. Sadjad, "230V-Multilevel DC-DC Converter for Low Input Voltage Range Using Adaptive Look-Up Table Tuned PI Controller," 2024 3rd International Conference on Power Systems and Electrical Technology (PSET), Tokyo, Japan, 2024, pp. 116-121, doi: 10.1109/PSET62496.2024.10808600.
17. S. Chimplee and S. Khwan-on, "Comparative Analysis of Fuzzy Controller Based on Input Current Slope and PI Controller for Two-Stage Cascaded Boost Converter," 2022 International Conference on Power, Energy and Innovations (ICPEI), Pattaya Chonburi, Thailand, 2022, pp. 1-4.
18. G. Ramesh and V. R. Babu, "Comparative Study of PI and Fuzzy Control Strategies to A Novel Buck-Boost Converter," 2022 First International Conference on Electrical,

Electronics, Information and Communication Technologies (ICEEICT), Trichy, India, 2022, pp. 1-6.

19. S. R. Kumar, P. Verma, M. K. Ram, S. R. Somanshu and M. N. Anwar, "H ∞ criterion based PI controller for DC-DC boost converter," 2022 IEEE 1st Industrial Electronics Society Annual On-Line Conference (ONCON), kharagpur, India, 2022, pp. 1-5.

20. M. Karuppiah, P. Dineshkumar and K. Karthikumar, "Design a Electric Vehicle Charger Based Sepic Topology with PI Controller," 2020 IEEE International Conference on Advances and Developments in Electrical and Electronics Engineering (ICADEE), Coimbatore, India, 2020, pp. 1-5.

21. A. Singh, K. Bharti and N. Kumar, "Performance analysis between Fuzzy Logic and PI controller in DC-DC Boost-Converter," 2024 IEEE International Conference on Smart Power Control and Renewable Energy (ICSPCRE), Rourkela, India, 2024, pp. 1-6.

22. L. Gupta, S. Bhandari and Deepika, "Modelling of Passivity based Controller for Buck Boost Converter," 2022 Second International Conference on Next Generation Intelligent Systems (ICNGIS), Kottayam, India, 2022, pp. 1-6.

23. A. Nath and D. Joshi, "Design and Control of PI Controller Based ZVS Boost Converter," 2025 IEEE DELCON - International Conference on Recent Smart Technologies in Engineering for Sustainable Development, New Delhi, India, 2025, pp. 1-8.

24. I. Laoprom, S. Tunyasirirut, W. Permpoonsinsup and D. Puangdownreong, "Voltage Control with PI Controller for Four Phase Interleaved Boost Converter," 2019 16th International Conference on Electrical Engineering/Electronics, Computer, Telecommunications and Information Technology (ECTI-CON), Pattaya, Thailand, 2019, pp. 278-281.

25. N. Genc, H. Uzmus and I. Iskender, "Dynamic behavior of dc-dc boost converter controlled with cascade PI-ASC," 2016 8th International Conference on Electronics, Computers and Artificial Intelligence (ECAI), Ploiesti, Romania, 2016, pp. 1-4.

26. K. Alam and A. Hoque, "Design and Analysis of Closed Loop Interleaved Boost Converter with Arduino based Soft PI Controller for Photovoltaic Application," 2019 IEEE International Conference on Electrical, Computer and Communication Technologies (ICECCT), Coimbatore, India, 2019, pp. 1-5.

27. L. Marín, V. Ramírez, D. Uribe and B. Saldivar, "Application of the LPO Algorithm to PI Controller Tuning: A Comparison with PSO in a Boost Converter," 2025 12th International Conference on Soft Computing & Machine Intelligence (ISCMI), Rio de Janeiro, Brazil, 2025, pp. 379-383.
28. D. Vimala, B. Lokeshgupta and V. Naresh Kumar, "Design and Analysis of DC-DC Boost converter using Model Predictive Controller," 2025 Fourth International Conference on Power, Control and Computing Technologies (ICPC2T), Raipur, India, 2025, pp. 1-5.
29. M. Maheshwari and M. Arounassalame, "Control of Integrated Quadratic Boost Sepic Converter for High Gain Applications," 2019 Fifth International Conference on Science Technology Engineering and Mathematics (ICONSTEM), Chennai, India, 2019, pp. 348-353.
30. S. Liaquat, O. S. Bhatti and K. A. Janjua, "Accelerated PSO-Scaled PI Controller for DC-DC Boost Converter in Photovoltaic Systems," 2019 3rd International Conference on Energy Conservation and Efficiency (ICECE), Lahore, Pakistan, 2019, pp. 1-6.
31. F. Kara and I. Aliskan, "PI Controller and Lag Compensator Design and Development for DC-DC Interleaved Boost Converter and Performance Analysis Under Disturbed Conditions," 2025 16th International Conference on Electrical and Electronics Engineering (ELECO), Bursa, Turkiye, 2025, pp. 1-6.
32. G. Ramesh and V. R. Babu, "Comparative Study of PI and Fuzzy Control Strategies to A Novel Buck-Boost Converter," 2022 First International Conference on Electrical, Electronics, Information and Communication Technologies (ICEEICT), Trichy, India, 2022, pp. 1-6.
33. G. Kaushik and M. Veerachary, "Two-Loop Controller Design For Quadratic Gain Following Boost Converter of Higher Order," 2025 IEEE 5th International Conference on Sustainable Energy and Future Electric Transportation (SEFET), Jaipur, India, 2025, pp. 1-6.
34. S. Rakshit and J. Maity, "Fuzzy Logic Controlled Ćuk Converter," 2018 International Conference on Communication and Signal Processing (ICCSP), Chennai, India, 2018, pp. 0771-0775.

35. M. E. Zachariah, G. K. Nisha and J. Babu, "Circulating Current Control of Parallel Connected Converters," 2020 Fourth International Conference on Inventive Systems and Control (ICISC), Coimbatore, India, 2020, pp. 649-654.
36. A. R. Kalaiarasi, M. Dharani, A. J. Josphin and A. Rithubarnika, "A Review on Error Reduction in a Closed-Loop Buck-Boost Converter Through the Implementation of Different Controllers," 2024 International Conference on IoT Based Control Networks and Intelligent Systems (ICICNIS), Bengaluru, India, 2024, pp. 677-683.
37. S. Prajapati, M. M. Garg and B. Prithvi, "Design of Fractional-Order PI controller for DC-DC Power Converters," 2018 8th IEEE India International Conference on Power Electronics (IICPE), Jaipur, India, 2018, pp. 1-6.
38. A. Kurniawan and A. Harumwidiah, "Comparison of Voltage Control Method on KY Converter," 2021 International Conference on Advanced Mechatronics, Intelligent Manufacture and Industrial Automation (ICAMIMIA), Surabaya, Indonesia, 2021, pp. 325-329.
39. R. Laksh mi, X. F. Joseph, S. Pushakumar and D. A. Dominic, "Design simulation and analysis of a soft switching scheme for DC-DC Boost Converter with a closed loop controller," 2011 International Conference on Emerging Trends in Electrical and Computer Technology, Nagercoil, India, 2011, pp. 370-374.
40. T. M. Minu Mathew and R. Rakhee, "Non-Isolated High Gain DC-DC Converter for PV Applications with Closed Loop Control," 2019 2nd International Conference on Intelligent Computing, Instrumentation and Control Technologies (ICICICT), Kannur, India, 2019, pp. 627-632.
41. B. Geethalakshmi, "Design of a closed loop control scheme for a DC-DC SEPIC converter using loop shaping method," 2015 International Conference on Circuits, Power and Computing Technologies [ICCPCT-2015], Nagercoil, India, 2015, pp. 1-5.
42. N. A. Sevostyanov, I. V. Alexandrov, R. L. Gorbunov and D. V. Makarov, "Step-by-Step Design of the Digital Closed Loop System of the Boost Voltage Converter," 2018 19th International Conference of Young Specialists on Micro/Nanotechnologies and Electron Devices (EDM), Erlagol, Russia, 2018, pp. 6403-6408.
43. K. K. Jha, M. N. Anwar, B. S. Shiva and V. Verma, "A Simple Closed-Loop Test Based Control of Boost Converter Using Internal Model Control and Direct Synthesis

Approach," in IEEE Journal of Emerging and Selected Topics in Power Electronics, vol. 10, no. 5, pp. 5531-5540, Oct. 2022.

44. K. Vishnu, R. K. Nema and A. Ojha, "Boost Converter with Fuzzy Logic, PI Controller and Sliding Mode Control for a Variable Source Input," 2020 International Conference on Computational Intelligence for Smart Power System and Sustainable Energy (CISPSSE), Keonjhar, India, 2020, pp. 1-5.

45. Divakar, P. Dwivedi and S. Bose, "Design and Analysis of Closed-Loop Control for Single-Phase Boost Rectifier by using Fractional Order PI Controller," IECON 2020 The 46th Annual Conference of the IEEE Industrial Electronics Society, Singapore, 2020, pp. 2951-2956.

46. R. Karan, S. Mishra and M. Kumar, "Small Signal Analysis of Non-Ideal Tri-State Boost DC-DC Converter for Low Power Circuits," 2023 IEEE 3rd International Conference on Smart Technologies for Power, Energy and Control (STPEC), Bhubaneswar, India, 2023, pp. 1-6.

47. A. J. Lari and A. Egwebe, "Switched Mode Power Supplies Comparison: PI, Cascade PI and Poiscast Controller," 2021 International Conference on Electrical, Computer and Energy Technologies (ICECET), Cape Town, South Africa, 2021, pp. 1-5.

48. S. Kumar and P. R. Thakura, "Closed loop PI control of DC-DC Cascode Buck-Boost converter," 2017 International Conference on Innovations in Information, Embedded and Communication Systems (ICIIECS), Coimbatore, India, 2017, pp. 1-6.

49. N. Kunjittipong, K. Kongkanjana and S. Khwan-on, "Comparison of Fuzzy Controller and PI Controller for a High Step-Up SingleSwitch Boost Converter," 2020 3rd International Conference on Power and Energy Applications (ICPEA), Busan, Korea (South), 2020, pp. 94-98.

50. M. A. Labbaf Khaniki, A. Hossein Asnavandi and M. Manthouri, "Boost PFC Converter Control using Fractional Order Fuzzy PI Controller Optimized via ICA," 2019 9th International Conference on Computer and Knowledge Engineering (ICCKE), Mashhad, Iran, 2019, pp. 131-136.

51. F. Kara and I. Aliskan, "PI Controller and Lag Compensator Design and Development for DC-DC Interleaved Boost Converter and Performance Analysis Under Disturbed

Conditions," 2025 16th International Conference on Electrical and Electronics Engineering (ELECO), Bursa, Turkiye, 2025, pp. 1-6.

52. S. Prajapati, M. M. Garg and B. Prithvi, "Design of Fractional-Order PI controller for DC-DC Power Converters," 2018 8th IEEE India International Conference on Power Electronics (IICPE), Jaipur, India, 2018, pp. 1-6.

53. A. Mamizadeh, N. Genc and R. Rajabioun, "Optimal Tuning of PI Controller for Boost DC-DC Converters Based on Cuckoo Optimization Algorithm," 2018 7th International Conference on Renewable Energy Research and Applications (ICRERA), Paris, France, 2018, pp. 677-680.

54. H. Doubabi, I. Salhi, M. Chennani and N. Essounbouli, "Voltage control of DC-DC Three level Boost converter using TS Fuzzy PI controller," 2019 6th International Conference on Control, Decision and Information Technologies (CoDIT), Paris, France, 2019, pp. 1266-1271.

55. D. Sivaraj and M. Arounassalame, "Fractional order PI controller for High gain boost converter," 2018 International Conference on Recent Trends in Electrical, Control and Communication (RTECC), Malaysia, Malaysia, 2018, pp. 281-286.

56. S. Padhmanabhaiyappan, R. Karthik and K. Ayyar, "Investigation of Controllers for DC-DC Boost Converter," 2018 International Conference on Power, Energy, Control and Transmission Systems (ICPECTS), Chennai, India, 2018, pp. 306-308.

57. Z. U. Haq and A. Ali, "Comparative study of Zeta converter and Boost converter Using PI controller," 2021 7th International Conference on Electrical, Electronics and Information Engineering (ICEEIE), Malang, Indonesia, 2021, pp. 54-59.

58. Vinod Kumar, Ranjan Kumar Behera, Dheeraj Joshi & Ramesh Bansal, "Power Electronics, Drives, and Advanced Applications," Book, 2020.

LIST OF PUBLICATIONS

1. V. Tomar and D. Joshi, "Performance Analysis of Boost Converter Under Nonlinear Scenarios," 2026 IEEE International Conference on Interdisciplinary Approaches in Technology and Management for Social Innovation (IATMSI), Gwalior, India, 2026, pp. 1-6, doi: 10.1109/IATMSI68868.2026.11465969. **(Published)**