

Study Of Non-Isolated Half-Bridge DC-DC Converter For Light Weighted EV Charging Applications

A DISSERTATION

SUBMITTED IN PARTIAL FULFILLMENT OF THE REQUIREMENTS
FOR THE AWARD OF THE DEGREE
OF
MASTER OF TECHNOLOGY
IN
CONTROL & INSTRUMENTATION

Submitted by

AYAN REHMAN
(2K24/C&I/11)

Under the supervision of

Dr. BHAVNESH JAINT
Mr. ROHAN PILLAI

Department of Electrical Engineering



DEPARTMENT OF ELECTRICAL ENGINEERING
DELHI TECHNOLOGICAL UNIVERSITY
(Formerly Delhi College of Engineering)
Bawana Road, Delhi 110042

MAY, 2026

DEPARTMENT OF ELECTRICAL ENGINEERING

DELHI TECHNOLOGICAL UNIVERSITY

(Formerly Delhi College of Engineering)

Bawana Road, Delhi-110042

CANDIDATE'S DECLARATION

I, Ayan Rehman, Roll No. 2K24/C&I/11, student of M.Tech (Control & Instrumentation), hereby declare that the project Dissertation titled "Study Of Non Isolated Half-Bridge DC-DC Converter For Light Weighted EV Charging Applications" which is submitted by me to the Department of Electrical Engineering, Delhi Technological University, Delhi in partial fulfillment of the requirement for the award of degree of Master of Technology, is original and not copied from any source without proper citation. This work has not previously formed the basis for the award of any Degree, Diploma, Associateship, Fellowship or other similar title or recognition.

Place: Delhi

Date: 02.06.2026

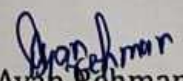
Ayan Rehman
(2K24/C&I/11)

DEPARTMENT OF ELECTRICAL ENGINEERING

DELHI TECHNOLOGICAL UNIVERSITY

(Formerly Delhi College of Engineering)

Bawana Road, Delhi-110042

CERTIFICATE

I hereby certify that the Project Dissertation titled "Study Of Non-Isolated Half Bridge DC-DC Converter For Light Weighted EV Charging Applications" which is submitted by Ayan Rehman, Roll No. 2K24/C&I/11, Department of Electrical Engineering, Delhi Technological University, Delhi in partial fulfillment of the requirement for the award of the degree of Master of Technology, is a record of the project work carried out by the student under my supervision. To the best of my knowledge this work has not been submitted in part or full for any Degree or Diploma to this University or elsewhere.

Place: Delhi

Date: 2.06.2026

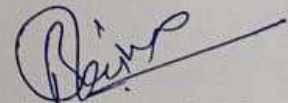

Dr. Bhavnesh Jaint

SUPERVISOR

Department of Electrical Engineering

Delhi Technological University

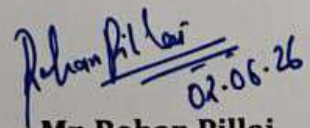

Mr. Rohan Pillai

SUPERVISOR

Department of Electrical Engineering

Delhi Technological University

DEPARTMENT OF ELECTRICAL ENGINEERING

DELHI TECHNOLOGICAL UNIVERSITY

(Formerly Delhi College of Engineering)

Bawana Road, Delhi-110042

ACKNOWLEDGEMENT

I express my sincere gratitude to **Dr. Bhavnesh Jain** & **Mr. Rohan Pillai** for guidance, support, and technical direction during the preparation of this project dissertation. I also thank specially **Mr. Krishna Dutt** for his precious time and guidance.

Thanks to the Department of Electrical Engineering, Delhi Technological University, for providing the academic environment required to study power quality, power electronic converters & charging systems.

I am thankful to my teachers, classmates, and colleagues for their suggestions during the development of the simulation-based study. I also acknowledge the source papers and thesis documents cited in this report.

Place: Delhi

Date: 02.06.2026

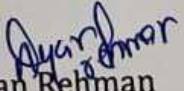
Ayan Rehman
(2K24/C&I/11)

ABSTRACT

The paper discusses the modeling, designing, and controlling processes of the non-isolated half-bridge DC-DC converter utilized in light-weight electric vehicle (EV) charging. The suggested converter facilitates effective conversion of electrical energy from a DC source to an EV battery and vice versa. Dynamic models are developed in order to represent and study the dynamics of the converter depending on the load and operational parameters. In order to provide secure and stable battery charging process, constant current/constant voltage (CC-CV) battery charging algorithm is designed. In CC state, the current of the battery is controlled by the charger controller whereas in the second case, when the battery voltage approaches its rated value, the controller shifts to CV state to charge the battery up to its maximum level. As a result, less pressure is put on the battery and higher efficiency of the charger is attained. It is found that due to the features and advantages of the half-bridge topology, the converter is quite efficient, has low current ripples, and rapid dynamics. Consequently, the suggested converter with CC-CV algorithm proves to be a cost-effective and highly efficient technology of future EVs charging.

Contents

Candidate's Declaration	i
Certificate	ii
Acknowledgement	iii
Abstract	iv
Contents	v
List of Tables	viii
List of Figures	ix
List of Symbols and Abbreviations	xi
1 INTRODUCTION	1
1.1 Growth of Electric Vehicles.....	1
1.2 Constant Current–Constant Voltage (CC–CV) Charging Algorithm	2
1.2.1 Literature Summary of CC–CV Charging Algorithm	3
1.3 Role of DC–DC Converter.....	4
1.3.1 Literature Summary of DC–DC Converter.....	4
1.4 Summary	5
2 BIDIRECTIONAL CONVERTER	7
2.1 Bidirectional DC–DC Converter.....	7
2.1.2 Bidirectional Converter Classification.....	9
2.2 Non-Isolated Bidirectional Converter.....	10
2.2.1 Buck & Boost Converter.....	10
2.2.2 Cuk Converter.....	11
2.3 Summary	11
3 CONTROL METHODOLOGIES	12
3.1 Control Method.....	12
3.1.2 Types of Controllers	12
3.1.3 P — Proportional Controller.....	12
3.1.4 PI — Proportional + Integral Controller.....	13
3.1.5 PD — Proportional + Derivative Controller.....	14
3.2.4 Classical PID Controller	16

3.2.5 Comparative Table.....	18
3.3 Summary	18
4 DC–DC CONVERTER TYPES AND MODELLING	19
4.1 DC–DC Converters.....	19
4.1.1 Types of DC–DC Converters.....	19
4.2 Modelling of the Converter Circuit.....	20
4.2.1 Design Specification of L, C.....	21
4.2.3 State-Space Equations Formulation.....	22
4.2.4 Buck Mode (Step-Down Operation).....	22
4.2.5 Boost Mode (Step-Up Operation).....	24
4.3 Summary	26
5 BATTERY TYPES	27
5.1 Battery Types in EVs.....	27
5.2 Key Technologies for BMS	27
5.2.1 Comparison of Different Battery Types	28
5.3 Battery Modelling	30
5.3.1 Battery Electric Model.....	30
5.3.2 Battery Thermal Model.....	32
5.3.3 Battery Coupled Electro-Thermal Model	32
5.4 Summary	33
6 BATTERY CHARGING APPROACHES	34
6.1 Charging Approaches.....	34
6.1.1 Traditional Battery Charging Approach	34
6.1.2 Battery State Estimation	39
6.1.3 SOH Estimation	40
6.1.4 SOC Estimation Algorithms	41
6.1.5 SOH Estimation Algorithms.....	42
6.2 Summary	43
7 OPTIMIZATION OF BATTERY CHARGING APPROACHES	44
7.1 Charging Performance of Batteries.....	44
7.1.1 CV Charging Optimization.....	44
7.1.2 CC–CV Charging Optimization.....	44
7.1.3 Improved CC–CV Charging Optimization.....	45
7.1.4 TLBO Based Charging Optimization	45
7.1.5 MCC Charging Optimization.....	46
7.1.6 Dynamic Programming Techniques	47

7.1.7 Pseudo-Spectral Optimization	48
7.2 Summary	49
8 SIMULATION RESULTS AND DISCUSSION	51
8.1 MATLAB/Simulink Model Description.....	51
8.2 Simulation	53
8.3 Circuit Parameters.....	53
8.4 Proposed Control Schematic of the Converter.....	54
8.5 Comparative Analysis.....	55
8.5.1 Reason for Simulating the Buck–Boost Converter.....	56
8.6 Results.....	58
9 CONCLUSION AND FUTURE SCOPE	59
9.1 Conclusion	59
9.2 Limitation.....	59
9.3 Summary	60
References	61

List of Tables

2.1 Advantages and Disadvantages of NBDC	10
3.1 Comparison of P, PI, Classical PID and PD Controller.....	18
5.1 Comparison of Different Battery Types for EV Applications	28
6.1 Battery Type and Its Charging Performance	36
6.2 Comparing Conventional Methods for EV Battery Charging	39
8.1 Comparison of Buck, Boost and Buck–Boost Converter	55

List of Figures

2.1 Classification of Non-Isolated Bidirectional Topologies	9
2.2 Circuit Diagram of Buck–Boost Converter	10
2.3 Circuit Diagram of Cuk Converter	11
3.1 Block Diagram of P Controller	12
3.2 Block Diagram of PI Controller.....	14
3.3 Block Diagram of PD Controller	15
3.4 Block Diagram of PID Controller.....	17
4.1 Bidirectional DC–DC Converter Circuit	20
4.2 Graph Battery Voltage response during discharge.....	22
4.3 Buck Mode Circuit Topology	23
4.4 Boost Mode Circuit Topology	24
5.1 Relationship Between the BMS’s Major Technologies.....	29
5.2 Three Battery Modelling Classes.....	30
5.3 Battery Circuit Diagram.....	32
6.1 Traditional Charging Approaches for Battery in EVs	36
6.2 The CC–CV Charging Method’s Battery Voltage and Current.....	38
6.3 The MCC Charging Method’s Battery Voltage and Current.....	38
7.1 Optimized Charging Approaches.....	47
7.2 Overview of Enhancements to the CC–CV/MCC Charging Strategy.....	49
9.1 Simulation Schematic of the Proposed Control Algorithm	53
9.2 Block Diagram of the Proposed Converter Control System.....	54
9.3 Graph Showing V Battery, I Battery Current	58

List of Symbols

Symbols

V_{DB}	Battery voltage at high voltage side (V)
V_{BT}	Battery voltage at low voltage side (V)
V_H	Voltage at high side (V)
V_L	Voltage at low side (V)
V_{in}	Input voltage (V)
V_{out}	Output voltage (V)
I_L	Inductor current (A)
I_{DB}	Input current (A)
I_o	Output current (A)
R_{DB}	Internal resistance of high-side battery (Ω)
R_{BT}	Internal resistance of low-side battery (Ω)
R_{LP}	Inductor parasitic resistance (Ω)
R_{dson}	MOSFET on-state resistance (Ω)
L	Inductance (H)
C_H	Input capacitor (F)
C_L	Output capacitor (F)
D	Duty cycle
f	Switching frequency (Hz)
ΔI_L	Inductor ripple current (A)
ΔV_o	Output voltage ripple (V)
Q_1	Switch 1 (MOSFET)
Q_2	Switch 2 (MOSFET)
D_1	Anti-parallel diode 1
D_2	Anti-parallel diode 2
$u(t)$	Controller output signal
$e(t)$	Error signal
K_p	Proportional gain
K_i	Integral gain
K_d	Derivative gain
$Q_{present}$	Present battery capacity
Q_{rated}	Rated battery capacity
P_o	Output power (W)
SOC	State of Charge (%)

List of Abbreviations

EV	Electric Vehicle
HEV	Hybrid Electric Vehicle
DC	Direct Current
AC	Alternating Current
CC	Constant Current
CV	Constant Voltage
CC–CV	Constant Current–Constant Voltage
MCC	Multi-Stage Constant Current
BDC	Bidirectional DC–DC Converter
NBDC	Non-Isolated Bidirectional DC–DC Converter
IBDC	Isolated Bidirectional DC–DC Converter
MOSFET	Metal–Oxide–Semiconductor Field-Effect Transistor
PWM	Pulse Width Modulation
PID	Proportional–Integral–Derivative
PI	Proportional–Integral
PD	Proportional–Derivative
SOC	State of Charge
SOH	State of Health
BMS	Battery Management System
Li-ion	Lithium-Ion
NiCd	Nickel–Cadmium
NiMH	Nickel–Metal Hydride
OCV	Open Circuit Voltage
KVL	Kirchhoff's Voltage Law
KCL	Kirchhoff's Current Law
V2G	Vehicle-to-Grid
SEPIC	Single-Ended Primary-Inductor Converter
TLBO	Teaching–Learning Based Optimization
PSO	Particle Swarm Optimization
MPC	Model Predictive Control
DP	Dynamic Programming
EIS	Electrochemical Impedance Spectroscopy
RC	Resistor–Capacitor
Ah	Ampere-hour

CHAPTER -1

INTRODUCTION

1.1 Growth of Electric Vehicles

The fast-paced development of electric vehicles has brought about a need for an effective charging system that is lightweight and compact. The need to protect our environment, exhaustion of natural fuels, and the necessity for sustainable means of transport have resulted in the extensive use of electric mobility systems. Batteries are one of the most crucial components of an electric vehicle; thus, an effective charging system is essential to the performance of such vehicles.

DC-DC converters play a significant role in controlling power conversion in EV charging systems. Among the different converter types, the non-isolated half-bridge DC-DC converter is considered to be one of the most favourable choices due to its simplicity, few components, low cost, high efficiency, and bi-directional operation.

The isolated half bridge DC-DC converter works without the use of a transformer to achieve galvanic isolation, thus leading to smaller size and light weight. The above features make this type of converter ideal for electric vehicle charging, where smaller and lighter devices are required. The converter allows for bi-directional flow of power between the source and the battery. In charge mode, electrical energy is transferred from the DC source to the battery. In discharge mode, power will flow from the battery to the DC load point.

The half-bridge converter normally works in two states:

1. Buck state, which is employed if the converter decreases the input voltage to charge the battery.
2. Boost state, which is used if the converter increases the battery voltage to supply energy to the system.

For a proper battery charging process, the proper battery charging algorithm needs to be developed. For this research, the CC-CV charging algorithm is developed.

For Constant Current mode (CC), the battery is charged at a constant charging current level. In this process, the battery voltage increases gradually to reach a pre-defined value.

Constant Voltage charging mode (CV) involves maintaining the battery voltage constant while reducing the charging current gradually to reach a minimal value. The charging technique prevents the battery from overcharging, increasing its lifespan and charging efficiency.

The proposed CC-CV control approach is employed with the non-isolated half-bridge DC-DC converter in order to ensure effective charging capability of lightweight EVs. Modelling and control analysis of the converter are carried out to investigate the behavior of the converter at various working modes. The performance of the system is analyzed using simulations to validate voltage regulation, current control, and charging operations.

1.2 Constant Current–Constant Voltage (CC–CV) Charging Algorithm

The Constant Current Constant Voltage (CC-CV) charging algorithm is one of the most frequently used techniques for the charging of batteries in electric vehicles due to its high level of effectiveness in providing the proper charging process. In particular, the suggested non-isolated half-bridge DC-DC converter uses the CC-CV technique for the regulation of the charging process of the battery.

Firstly, the battery is charged through the Constant Current (CC) stage when the charger provides the reference current to the battery. In this case, while the reference current is maintained, the battery voltage grows as the SOC increases. This stage is usually used when the battery charge is rather low or medium. With such an approach, it is possible to achieve higher efficiency in energy charging.

Secondly, as soon as the maximum battery voltage is reached, the charging process switches to CV mode. During this stage, the battery voltage regulator maintains the battery voltage at a constant level, whereas the charging current progressively decreases. As a result, there is no overheating of the battery and no risk of overcharge. The CC-CV charging increases efficiency and increases battery life through precise charging current and voltage control. The proposed bidirectional converter system uses a controller that monitors battery conditions and changes modes based on the requirements. The use of CC-CV method results in increased system stability, increased charging precision, and overall system performance.

Sequence of Events During CC-CV Charging

- 1.The battery is charged using the CC mode initially.
- 2.The controller provides a set current throughout the charging process.
- 3.The output voltage is constant in CV mode.
- 4.The battery charging current gradually lowers as charging continues.
- 5.The entire charging process ends once the battery achieves the required state-of-charge.

1.2.1 Literature Summary of CC-CV Charging Algorithm

The CC-CV charging algorithm is one of the most popular charging algorithms for secondary batteries, especially in electric vehicles (EVs), owing to its easy applicability, high efficiency, and capacity to ensure safety of the batteries. Various researchers have explored the application of CC-CV charging methods in battery charger systems and power electronic converters.

The early literature on battery charging methods noted that the CC-CV method is a successful charging method for lithium-ion batteries that are mostly used in EVs due to their high energy density and durability. The method begins by using a constant current to charge the battery quickly, but its voltage increases gradually at this point. Once the voltage attains a particular value, then the system changes to CV mode, where the current drops gradually until the battery is charged fully.

Various studies have used the CC-CV charging algorithm in DC-DC converters-based charging systems, where the main aim is the attainment of precise charging parameters of the batteries. The integration of closed loop controllers within CC-CV systems has shown that the algorithm has resulted in better voltage regulation and effective current control. Bidirectional converters are those in which the algorithm plays a key role in transferring energy efficiently from the source to battery storage systems.

Several studies have emphasized on the implementation of the CC-CV charging algorithm along with bidirectional DC-DC converters. They revealed that the CC-CV approach ensures stable charging operations, prevents battery overcharging and decreases stress on battery cells. In addition, when CC-CV charging and PID controller control algorithms are combined, there is better dynamic performance and minimized steady-state error.

Several researchers have evaluated the performance of the CC-CV charging algorithm compared to more sophisticated methods like pulse charging, fuzzy logic-based charging algorithms and model predictive control algorithms. Although advanced approaches might offer higher charging speed or adaptive control features, the CC-CV algorithm is still highly popular because of its lower computational requirements and simplicity of implementation.

CC-CV charging algorithm also plays a key role in non-isolated DC-DC converters. Since the algorithm regulates currents and voltages as per battery charge states, it enhances converter performance and increases battery lifespan. Therefore, the CC-CV algorithm still is a proper option for lightweight EV charger applications.

1.3 Role of DC-DC converter

DC-DC converters are important in power electronic circuits since they regulate and convert DC voltage levels based on the needs of a particular application. This is critical in enhancing the efficiency, performance, and stability of power electronic circuits in applications such as renewable energy sources (such as solar panels and fuel cells), electric vehicles, mobile electronics, and industrial automation. The main purpose of DC-DC converters is to boost or buck input voltage or isolate output voltage. They ensure that components with different voltage specifications can be effectively incorporated into one circuit.

1.3.1 Literature Summary of DC–DC Converter

There has been considerable focus on electric vehicles (EVs) owing to the growing need for sustainable modes of transport along with lessening the amount of carbon emission. DC to DC converters find extensive use in battery charging applications, voltage regulation, and power management systems. Hence, there has been considerable research done on the designs of converters, modelling techniques, and control strategies for EV charging applications.

Traditional DC to DC converters such as buck, boost, and buck boost converters are generally used for converting the input DC to an output DC of lower or higher value based on their operating characteristics. The buck converter acts as a step-down converter while providing a regulated output voltage using a simple circuit design approach. On the other hand, the boost converter is used in applications where there are a step-up requirement of voltage and the output voltage needed is higher than the input voltage.

DC–DC converters can be divided into two main categories, including isolated and non-isolated converters. Transformer usage is typical of isolated converters, which helps to achieve electrical isolation between the input and the output sides of the converter. The most used isolated converter topologies are flyback, forward, push-pull, half-bridge, and full-bridge converters. These converters are mainly employed in cases where galvanic isolation and voltage gain are important. Recently, non-isolated converters have been gaining popularity for the purpose of EV charging because of their simple structure, low cost, lightweight, and high-power density. Lightweightness is an important characteristic of electric vehicles; hence, the adoption of non-isolated converters

would be a feasible approach rather than using the common isolated converters. In addition, the simple topology of non-isolated converters reduces conduction losses.

In cases involving battery charging and energy storage, the use of bidirectional DC–DC converters is common due to their ability to transfer electrical energy in both the forward and reverse directions. For example, in the charging system of electric vehicles, battery charging takes place in case of forward power transmission while energy regeneration occurs in case of reverse power transmission. Bidirectional DC-DC converters can be used in regenerative braking systems, energy storage, and vehicle-to-grid applications.

There are various Regarding bidirectional converter topologies, the half-bridge DC-DC converter with no isolation is considered one of the best topologies for lightweight EV charging due to features such as low number of semiconductor components, low switching stresses, small size, and bidirectional energy transmission capabilities. Based on these features, there has been significant research done on using this topology for charging EV batteries.

Converter modelling for DC-DC converters is critical to analyse the dynamic behaviours of the converter and provide proper controllers. Modelling helps predict system performance and obtain the necessary transfer functions for the controllers. Many approaches have been suggested for controlling bidirectional converters including proportional integral derivative (PID) control, voltage mode control, current mode control, and digital control approaches. PID control approaches are among those control strategies which are often used because of their simplicity, good transient response, and regulation abilities.

The commonly used algorithm for charging Li-ion batteries used in electric vehicles is that of Constant Current-Constant Voltage (CC-CV) charging. Under the constant current step, the battery is charged using a specified charging current until the preset voltage level of the battery is achieved. After that, the system goes into the constant voltage state where the voltage remains constant, but the current reduces. Using CC-CV algorithm and bidirectional DC-DC converters will result in better efficiency, better safety measures and efficient charging process.

Despite many technological advances, there are still many technical difficulties in terms of efficiency, small size converter structure, efficient control and battery charging process in the light-weight EV systems. For this reason, modelling and controlling a half-bridge bidirectional DC-DC converter with CC-CV charging algorithm can be considered as an important option.

Objective.

- 1.The main objective of this research is to model and control the non-isolated half-bridge DC-DC converter for lightweight EV charging.
- 2.The analysis of the converter, modelling, control of the converter, and implementation of a CC-CV algorithm are the key aspects of the system design.
- 3.The proposed converter system seeks to regulate the current and voltage accurately, transfer power bidirectionally, ensure stability in the operation of the converter, and charge/discharge batteries reliably.

1.4 Summary

This chapter introduced the growing importance of electric vehicles (EVs) and the need for efficient, lightweight, and compact charging systems. It explained the role of the non-isolated half-bridge DC-DC converter in EV charging applications due to its simple structure, low cost, high efficiency, and power flow capability. The chapter also discussed the operation of the converter in buck and boost modes and emphasized the significance of the Constant Current–Constant Voltage (CC–CV) charging algorithm for safe and efficient battery charging. In addition, a literature review on CC–CV charging techniques and DC-DC converters was presented, highlighting their importance in improving battery life, charging stability, and converter performance in lightweight EV systems.

CHAPTER 2

BIDIRECTIONAL CONVERTER

2.1 Bidirectional DC–DC Converter

A bidirectional DC–DC converter is a power electronic converter that can move electrical energy between two DC sources and DC buses running at different voltage levels in both directions. Bidirectional converters enable both charging and discharging operations, in contrast to traditional unidirectional converters that only permit power transmission from source to load.

Bidirectional DC–DC converters are essential for controlling energy exchange between the battery pack and the DC bus in electric vehicle applications. When the battery is in charging mode, electrical energy is sent to it from an external power source or charging station. During discharging mode, the stored battery energy is supplied back to the vehicle motor drive, auxiliary systems, or DC link according to operational requirements. Controlling bidirectional power flow enhances overall efficiency, energy use, and system adaptability. The operation of a bidirectional converter generally involves two working modes known as buck mode and boost mode. The converter lowers the input voltage to a level appropriate for battery charging when it is operating in buck mode. In boost operation, the converter increases the battery voltage to a higher voltage level to meet the requirements of the load or DC bus. Bidirectional converters are ideal for EV charging systems and battery management applications due to their dual operating properties.

Isolated and non-isolated topologies are the two main categories of bidirectional DC-DC converters. Transformers are used in isolated converters to create galvanic isolation between the input and output sides. This configuration increases system size, cost, circuit complexity, and total weight even while it enhances electrical safety and voltage matching capacity. On the other hand, non-isolated converters eliminate the transformer requirement, resulting in a simpler design, reduced component count, improved efficiency, and higher power density. As a result, non-isolated topologies are frequently chosen for applications involving lightweight electric vehicles.

Buck-boost, Cuk, SEPIC, half-bridge, and full-bridge configurations are among the non-isolated bidirectional converter topologies that have been created. Among them, the non-isolated half-

bridge bidirectional DC–DC converter has drawn a lot of interest due to its small size, excellent efficiency, ease of control implementation, and suitability for bidirectional energy transmission. The converter typically uses semiconductor switches, inductors, and capacitors to achieve controlled power conversion between low-voltage and high-voltage DC buses.

A bidirectional converter's control method has a significant impact on its performance. An efficient controller is necessary to maintain stable operation and precise power regulation since converter operation involves switching actions, nonlinear behaviour, and fluctuating load circumstances. Control techniques such as PID, PI, fuzzy logic, and model predictive control are commonly used to regulate output voltage, charging current, and power flow direction. In EV charging applications, effective battery charging, accurate current management, and enhanced battery protection are made possible by coupling an appropriate controller with a Constant Current–Constant Voltage (CC–CV) charging algorithm.

In modern electric vehicle systems, bidirectional converters also support advanced functionalities such as regenerative braking and battery energy storage integration. These applications allow energy recovery and intelligent power exchange between the vehicle and external electrical systems. Consequently, bidirectional DC–DC converters have become an essential component in developing efficient, reliable, and lightweight EV charging and energy management systems.

These BDCs are categorized into Non-Isolated Bidirectional DC-DC Converters (NBDCs) and Isolated Bidirectional DC-DC Converters (IBDCs) and further these are grouped according to their configurations and voltage-boosting methods. Buck-boost, Cuk, SEPIC, and ZETA converters are basic NBDC configurations that provide straightforward and affordable solutions for low-power applications. Additionally, high-power applications can benefit from sophisticated designs including switched capacitor, cascaded, interleaved, and multilevel bridges, which provide improved efficiency, reduced switching losses, and simple control techniques. Flyback, Cuk, Push-pull, and Forward converter are the fundamental IBDC setups. It offers affordable, user-friendly solutions for applications using moderate voltage.

2.1.1 Bidirectional Converter Classification

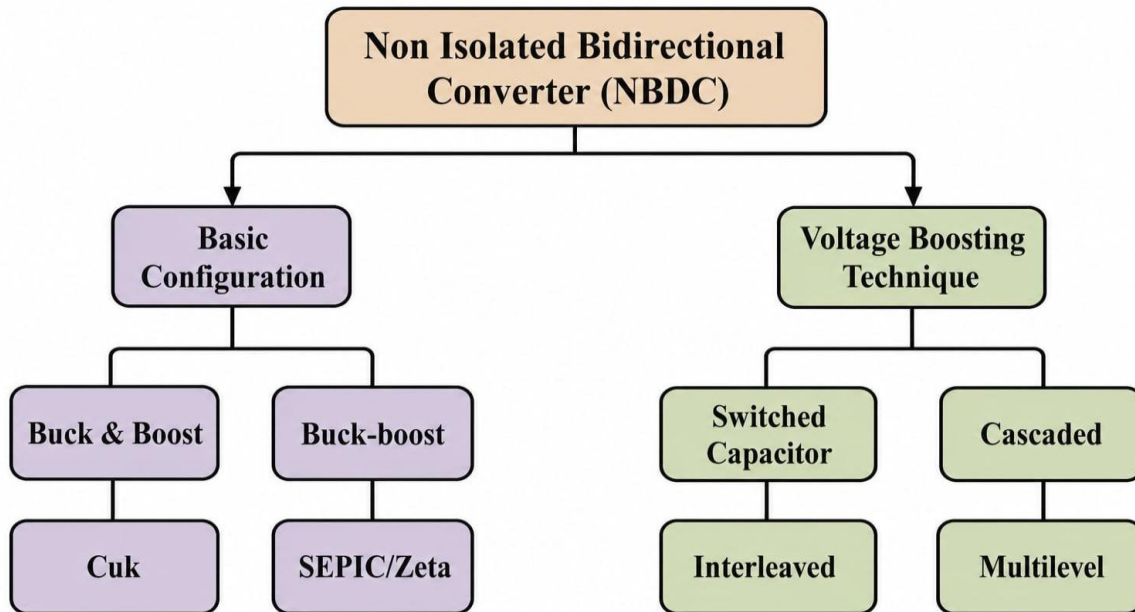

Fig.2.1 Classification of Non-Isolated Bidirectional topologies

Bidirectional DC-DC converters (BDC) come in two main varieties: isolated and non-isolated. NBDCs transmit power in the lack of magnetic isolation, meaning they do not utilize a transformer for the power exchange, whereas isolated bidirectional converters are used in a number of power applications due to their efficiency, dependability, low weight, and compactness. This has the disadvantage of low voltage gain and simpler construction, but it is superior to IBDCs in many situations where weight and compactness are important considerations. Leakage inductance and magnetic interference occur when DC is transformed to AC and then rectified back into DC after passing through a high-frequency transformer. Non-isolated bidirectional converters without magnetic coupling, which only include switching devices and passive components, may be advantageous in applications where efficiency and high voltage gain are not critical criteria. However, magnetic coupling is used to obtain high voltage gain, which improves efficiency and dependability. NBDCs are categorized using voltage boosting and basic configuration methods. The bidirectional converter's simpler structure yields basic configurations, while rearranging this simpler structure yields voltage boosting strategies.

Table 2.1 Advantage and Disadvantages of NBDC.

Advantages	Disadvantages
1. A construction that is balanced	1. only functions in either boost or buck mode.
2. Minimal ripple current on both sides	2. Its design (structure) is unworkable for larger voltage ratios.
3. broad voltage working range	3. Reduced galvanic isolation between the two sides
4. Basic circuitry for drivers	4. An increased duty cycle ratio is necessary for higher voltage gain.

2.2 Non-Isolated Bidirectional Converter

2.2.1 Buck & Boost Converter

In order to lower and raise voltage, respectively, a step-down converter is arranged in anti-parallel with a step-up converter. In the past, the activities were carried out using unidirectional switches such as MOSFETs and diodes. Due to its unidirectional power flow and lack of a current conduction route for the diode in reverse direction, these unidirectional switches were eventually replaced with bidirectional switches. But for NBDCs, this is accomplished by swapping out unidirectional switches, as Fig. illustrates. When the output voltage (V) exceeds the input voltage (V_{LH}), boost mode takes place; when the opposite is true, buck mode

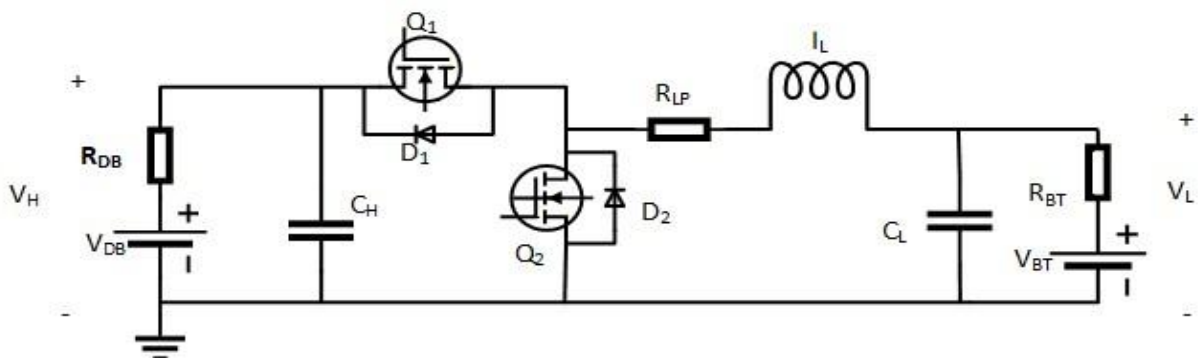

Fig.2.1. Circuit diagram of buck boost converter

Although a diode can be used in a variety of applications, its high-power application effect during step down reduces the circuit's efficiency. In boost mode, the output voltage (V_H) is greater than

the input voltage (V_L), while in buck mode, the opposite is true, but the output voltage's polarity is changed, resulting in ripple. More switches are added to the circuit in order to ignore these problems.

2.2.2 Cuk Converter.

A MOSFET is used in place of the primary diode to create a Cuk converter. Cuk converters provide constant input and output current. By using a coupled inductor, current ripples in the converter's input and output are eliminated. To enable both greater and lower output voltages, Cuk converters are interfaced with energy storage systems in Fig.2.2.boost and buck configurations that are connected in series with energy storage capacitors.

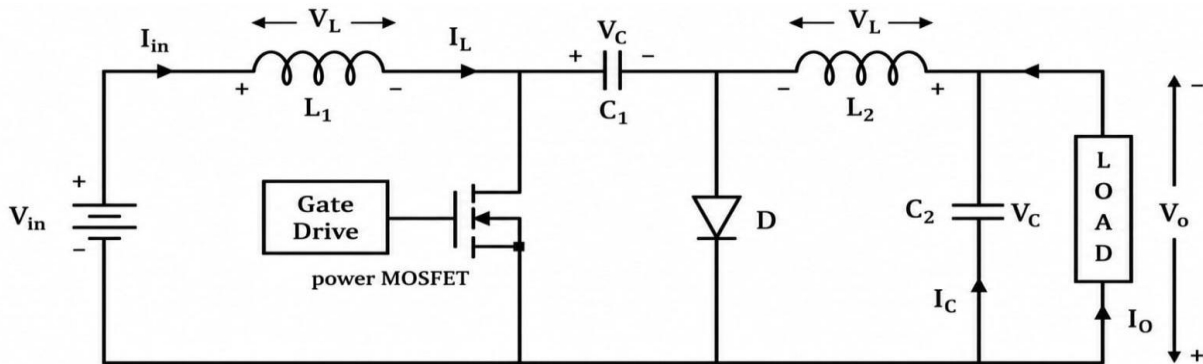

Fig.2.2. Circuit diagram of cuk converter

by reorganizing the Cuk converter as shown in Fig.2.2. These converters have comparable DC bus polarity and both higher (V_H) and lower (V_L) voltages. Converters function as SEPIC and ZETA when electricity flows from lower voltage (V_L) to higher voltage (V_H).

2.3 Summary

The chapter provided an understanding of the working principle and use of the bidirectional DC-DC converters that are involved in the charging and energy storage process. It further highlighted the uses of these converters in situations where power is transferred both during the charging and discharging process. This included regenerative braking and V2G energy systems. The isolation or non-isolation characteristics of converters have been classified in terms of their pros and cons. Various non-isolated converters have also been mentioned, including buck boost, Cuk, SEPIC, and half bridge converters. Of these non-isolated types of converters, the non-isolated half-bridge bidirectional converter appears to be the best for light-weight EV applications.

CHAPTER 3

CONTROL METHODOLOGIES

3.1 Control Method

Control methodologies are the techniques used to regulate and control the operation of a DC–DC converter to achieve stable output voltage, current regulation, and efficient power transfer. In power electronic systems, an effective control methodology ensures proper converter performance under varying load and operating conditions.

3.1.1 Types of Controllers

The four types of controllers that comprise the PID controller family are proportional (P), proportional plus integral (PI), proportional plus derivative (PD), and proportional plus integral plus derivative (PID).

3.1.2 P — Proportional Controller

A proportional controller (P-controller) refers to the kind of feedback controller where the control input $u(t)$ of the controlled system is altered based on the error $e(t)$ obtained between the setpoint and the actual value of output $y(t)$. This kind of controller is widely used in closed-loop control systems to make sure that the output of the system closely matches the setpoint.

The plant is the name given to the controlled system and it may be any kind of system (mechanical, electrical, hydraulic, etc.). During simulation, it can be modelled using a system of differential equations or state-space representation or as a transfer function.

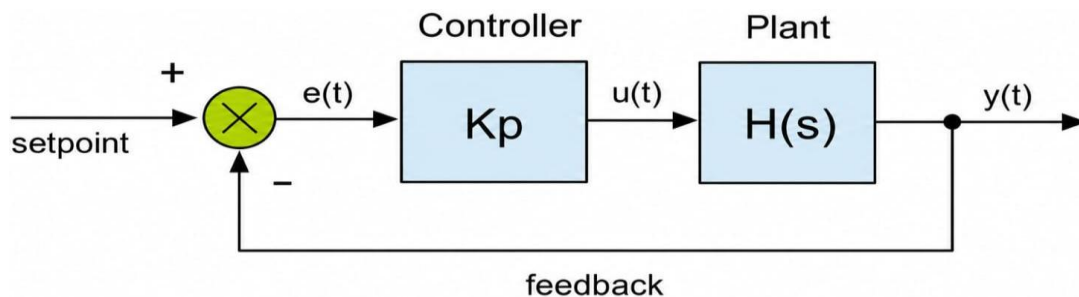

Fig 3.3 Block diagram of P controller

Formula: $u(t) = K_p \times e(t)$ (3.1)

where:

$u(t)$ – control signal (output of the controller)

$e(t)$ – error signal (input to the controller)

K_p – proportional gain

The output is directly proportional to the current error. If the error is large, the correction is large; if small, correction is small.

Characteristics:

- 1) Quick response time
- 2) Ever produces a steady state error (can never get rid of this)

Higher K_p leads to faster response and higher overshoot

Applications include:

Controlling speed, regulation that permits some error.

3.1.3 PI — Proportional + Integral Controller

The other name for the proportional integral controller is Proportional Plus Integral or simply called the PI Controller. The reason why it was called a PI controller is because it is the result of combining two controllers, namely the proportional and the integral controller. The use of proportional and integral in the controller gives rise to its efficiency due to the elimination of its shortcomings.

Formula: $m(t) = K_p \cdot e(t) + K_i \cdot \int e(t) dt$ (3.2)

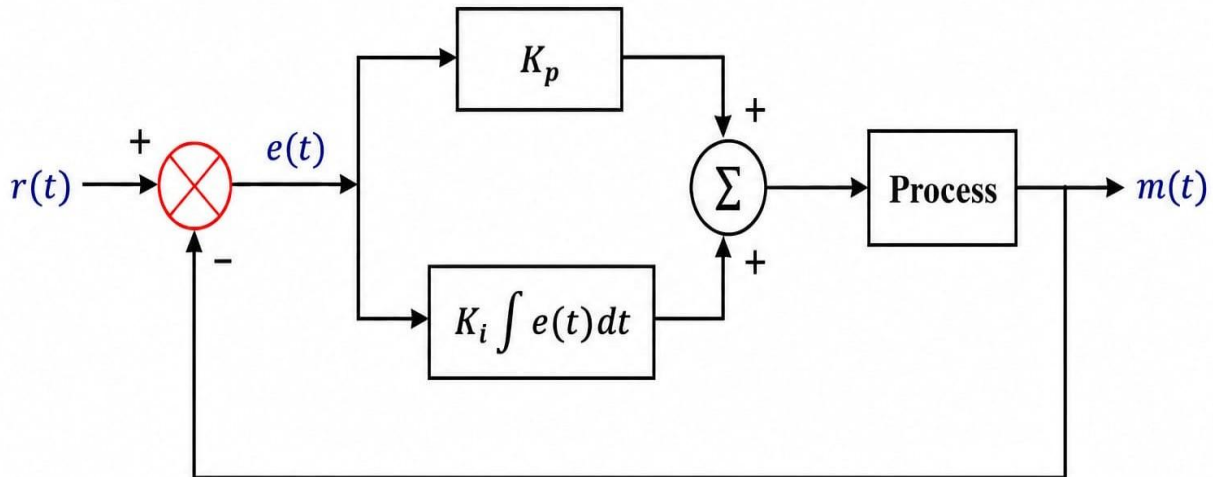

Fig.3.4. Block diagram of PI controller

Combines the fast response of P with the error-eliminating power of I.

Characteristics:

- 1) Eliminates steady-state error
- 2) Good speed of response
- 3) Slightly more overshoot than P alone
- 4) No derivative action, so doesn't dampen oscillations as well

Transfer function: $C(s) = K_p + K_i/s = (K_p \cdot s + K_i)/s$ (3.3)

Application:

Most common in industry — motor drives, power converters, temperature control. Used in bidirectional DC-DC converter current/voltage loops

3.1.4 PD — Proportional + Derivative Controller

A controller that uses both the error and derivative terms of the error as the input to produce an output is called the proportional derivative controller.

The proportional derivative controller combines both actions of a proportional and a derivative controller.

From experience, it is known that using controllers in any control system helps improve the performance of the overall system. Using two controllers, therefore, makes the system more precise.

Formula: $u(t) = K_p \cdot e(t) + K_d \cdot de(t)/dt$ (3.4)

Combination of proportional control and derivative control for better transient performance.

Features:

- 1) Quicker response and reduced overshoot compared to proportional control only
- 2) Good damping for oscillatory responses
- 3) But still has steady-state error as no integrator control
- 4) More sensitive to measurement noise because of the derivative controller

Transfer function:

$C(s) = K_p + K_d \cdot s$ (3.5)

Application:

Used in position control systems, mechanical servo systems where noise levels are minimal.

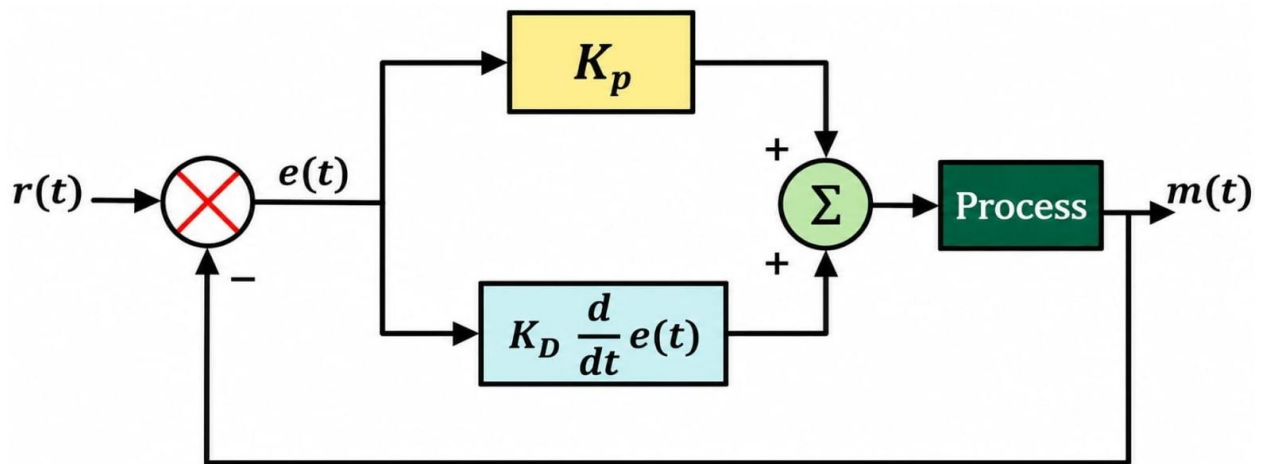

Fig.3.5. Block diagram of PD controller

3.1.5 Classical PID Controller

PID controllers are the most frequently applied control system type in industrial processes and include proportional, integral, and derivative action terms. PID control has developed since Minorsky's work on stabilizing automatic steering in 1922 and has been utilized for almost a hundred years for both linear and nonlinear systems. These controllers can be used either separately (proportional, integral, or differential action) or in combinations such as proportional-integral, proportional-differential, and proportional-integral-differential control to create the appropriate control signal to stabilize the process by reducing the error. Even with advancements in intelligent control techniques, PIDs are still vital components of around 95% of all current closed-loop industrial processes due to their simplicity and efficiency.

Applications:

To control process variables like temperature, velocity, pressure, position, or flow.

PID stands for:

P → Proportional

I → Integral

D → Derivative

The controller constantly computes an error:

"Error" = "Set Point" – "Measured Value"

and applies a corrective control signal based on three terms.

The standard PID equation is:

$$u(t) = K_p e(t) + K_i \int e(t) dt + K_d \frac{de(t)}{dt} \quad (3.6)$$

Where:

- $u(t)$ = controller output
- $e(t)$ = error
- K_p = proportional gain

- K_i = integral gain
- K_d = derivative gain

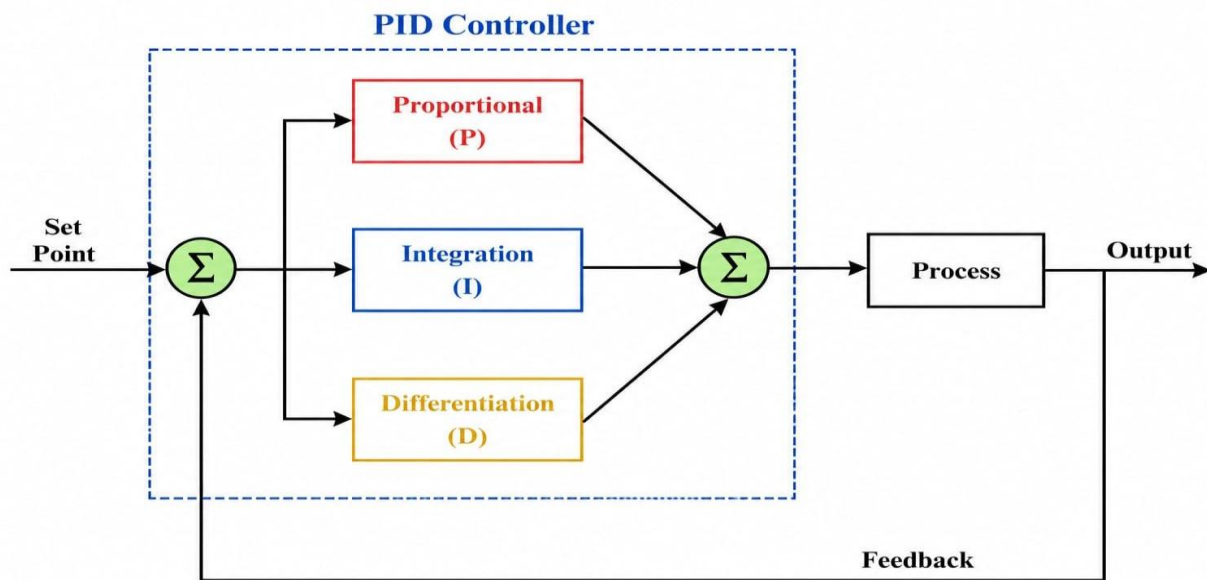

Fig.3.6. Block diagram of PID controller

Advantages of PID Controller

PID controllers are simple and efficient, offering fast response, stability, and adaptability.

Disadvantages

- 1) The controller might have a difficult time in a complex linear system.
- 2) Tuning could be hard to achieve, given that PID consists of three parameters.

3.1.5 Comparative Table:

Table 3.1 of P,PI,Classical PID and PD Controller

Feature	P Controller	PI Controller	Classical PID Controller	PD Controller
Control Law	$u(t)=K_p e(t)$	$u(t)=K_p e(t)+K_i \int e(\tau)d\tau$	$u(t)=K_p e(t)+K_i \int e(\tau)d\tau+K_d de(t)/dt$	$u(t)=K_p e(t)+K_d de(t)/dt$
Transfer Function	$G_c(s)=K_p$	$G_c(s)=K_p+K_i/s$	$G_c(s)=K_p+K_i/s+K_d s$	$G_c(s)=K_p+K_d s$
Parameters	K_p	K_p, K_i	K_p, K_i, K_d	K_p, K_d
Steady-State Error	Reduces but does not eliminate	Eliminates for step input	Eliminates for step input	Same as P controller
Rise Time	Decreases with increase in K_p	Decreases	Faster than P and PI	Decreases
Overshoot	Increases with K_p	Increases	Reduced by K_d	Decreases
Settling Time	Small change	Increases	Decreases with proper tuning	Decreases
Stability	Stable for proper K_p	May become oscillatory	Stable with proper tuning	Stable for proper tuning
Advantages	Simple and easy to implement	Eliminates steady-state error	Best overall performance	Improves transient response
Disadvantages	Steady-state error remains	Slower response and more overshoot	Complex and requires tuning	Noise sensitive
Applications	Simple systems	Zero steady-state error systems	Industrial control systems	Improved transient response systems

3.2 Summary

In this chapter, different approaches that are employed for control of voltages, currents, and operation of DC-DC converters have been described. Proportional (P), proportional-integral (PI), proportional-derivative (PD), and classical PID controllers and their features including equations, transfer functions, benefits, drawbacks, and use cases have been highlighted. A comparative study revealed that PID controllers offer the most advantageous features because they have the fastest response time, lowest steady state error, and higher stability as compared to other controllers. It can be concluded that the selection of an appropriate controller is very important for successful DC-DC converter operation

CHAPTER 4

DC-DC CONVERTER-TYPES OF DC-DC CONVERTER AND MODELLING OF THE CONVERTER CIRCUIT

4.1 DC- DC CONVERTERS

A converter is an electrical circuit that takes DC input voltage and generates a different level of DC voltage, usually employing high-frequency switching and inductive-capacitive filters. It alters electrical energy for particular applications— increasing voltage, changing polarity, or generating multiple outputs with changing signs. There are six primary classes of converters: AC to DC, DC to DC, AC to AC, DC to AC, and Static Switches. Converters include two major parts: controllers and filters. Filters drive the electrical signals, and their construction in many cases is based on the Maximum Power Transfer Theorem. Controllers play the role of the system's mind, deciding how the converter (the heart of the system) works. Together, they control power flow and guarantee energy conversion efficiency. Converter design includes both power and control circuitry. They are crucial in systems that need stable and precise power, such as renewable energy configurations, electric vehicles, portable devices, and industrial automation. Converter circuits convert direct current from a power source to a desired voltage level, making energy use reliable and flexible in most modern applications.

4.1.1 TYPES OF DC-DC CONVERTERS

1. Buck Converter (Step Down)

lowers the output voltage by lowering the input voltage. used when a voltage lower than the source is needed. $V_{out}=D \cdot V_{in}$, (4.1)
where D is the duty cycle.

2. Boost Converter (StepUp)

raises the output voltage by increasing the input voltage. frequently found in battery-operated systems that require higher voltage.

$$V_{out} = \frac{V_{in}}{1-D} \quad (4.2)$$

Where:

- V_{in} = Input voltage
- V_{out} = Output voltage
- D = Duty cycle

3. Buck boost converter (step up-step down)

Power electronic converter that may either raise (boost) or lower (buck) the input voltage based on operational needs is called a Buck–Boost Converter.

$$V_{out} = D V_{in} \text{ (Buck)}, V_{out} = \frac{V_{in}}{1-D} \text{ (Boost)} \quad (4.3)$$

Where:

- V_{in} = Input voltage
- V_{out} = Output voltage
- D = Duty cycle

4.2. Modelling of the converter circuit

Objective.

The development of an equation to model the dynamical behavior of the current flowing through the inductor and DC link/output capacitors voltage during the boost (step up) and buck (step down) conversion process is the aim of the modeling process. The circuit will behave as a boost converter when operating in step up mode and as a buck converter in step down mode.

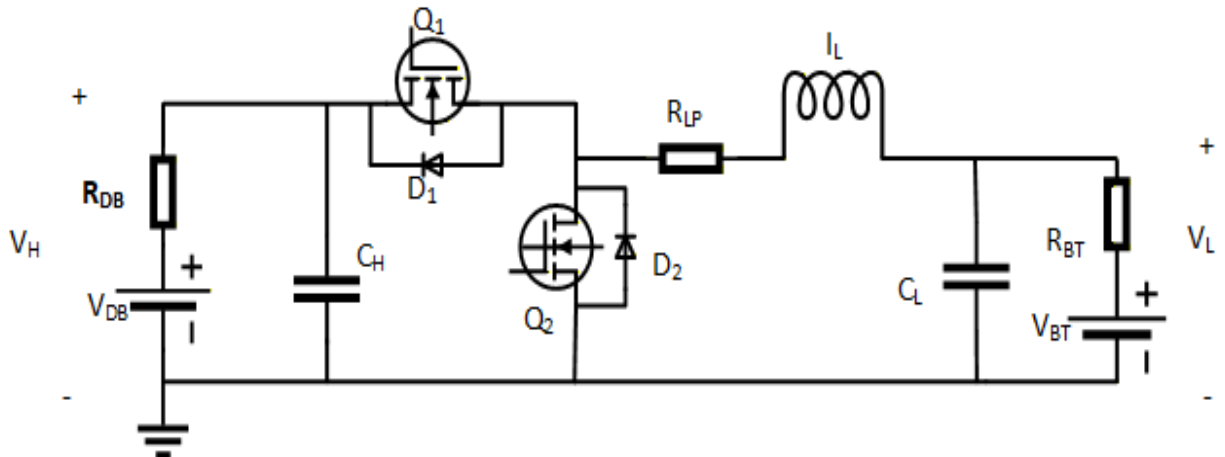

Fig.4.1. Bidirectional DC-DC converter circuit

Circuit description & notation.

- V_{DB} : is the battery voltage at high voltage side,
- V_{BT} : is the battery voltage at low voltage side,
- R_{DB} and R_{BT} are the internal resistance of V_{DB} and V_{BT} , respectively.
- The circuit consists of energy storage components such as inductor L , input capacitor C_H , and output capacitor C_L .
- There are two switches (using MOSFET) Q_1 and Q_2 with their internal resistance R_{dson} .

- These switches also connect with anti-parallel diodes D_1 or D_2 , acting as a free-wheeling diode during operations mode. Inductor parasitic resistance RLP is included in the mode

4.2.1 Design specification of L, C

Inductor Ripple Current

$$\Delta I_L = \frac{V_{in}D}{Lf}$$

$$\Delta I_L = \frac{200 \times 0.193}{290 \times 10^{-6} \times 20000}$$

$$\Delta I_L = 6.65A \quad (4.4)$$

Inductor Calculation

$$L = \frac{V_{in}D}{\Delta I_L f}$$

$$L = \frac{200 \times 0.193}{6.65 \times 20000}$$

$$L = 290 \times 10^{-6} \text{ H}$$

$$L = 290 \mu H \quad (4.5)$$

Output Voltage Ripple

$$\Delta V_0 = \frac{I_0 D}{fC}$$

$$\Delta V_0 = \frac{21 \times 0.193}{20000 \times 525 \times 10^{-6}}$$

$$\Delta V_0 = 0.386V \quad (4.6)$$

Capacitor Calculation

$$C = \frac{I_0 D}{f \Delta V_0}$$

$$C = \frac{21 \times 0.193}{20000 \times 0.386}$$

$$C = 525 \times 10^{-6} \text{ F}$$

$$C = 525 \mu F \quad (4.7)$$

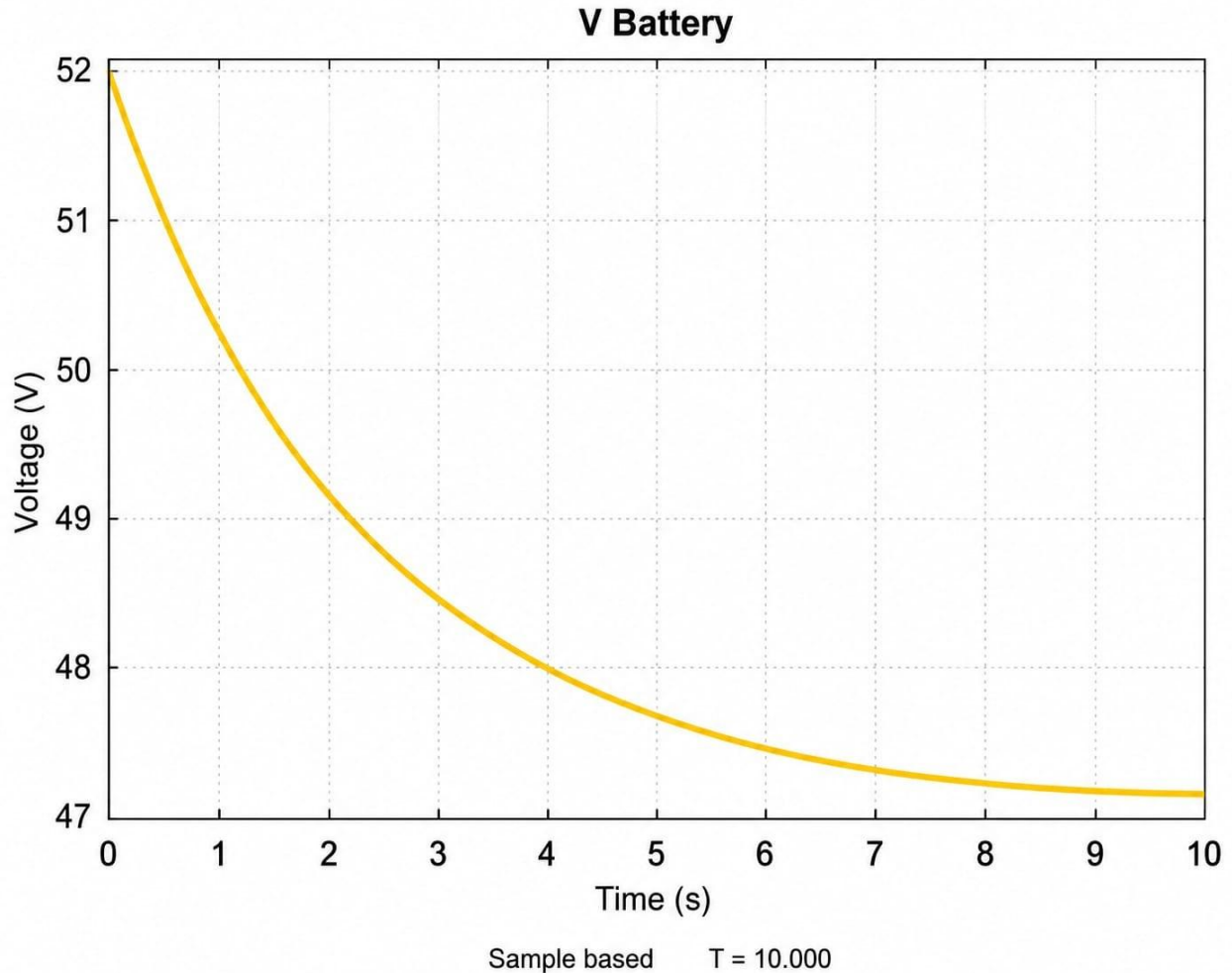

Fig.4.2. Battery voltage response during discharge

4.2.2 State-Space equations Formulation

With continuous current conduction, the bidirectional DC-DC converter operates in two modes: step-down and step-up. For both modalities, mathematical models have been created.

4.2.3 Buck mode (Step-Down Operation)

Power flows from the higher voltage side to the lower voltage side (source to load) during buck mode operation. The switching sequence allows the inductor to transfer energy to the load while smoothing the current.

Mathematical Modelling

Let's Define state variables:

$I_L(t)$: Inductor current

$V_H(t)$: Voltage at high side

$V_L(t)$: Voltage at low side

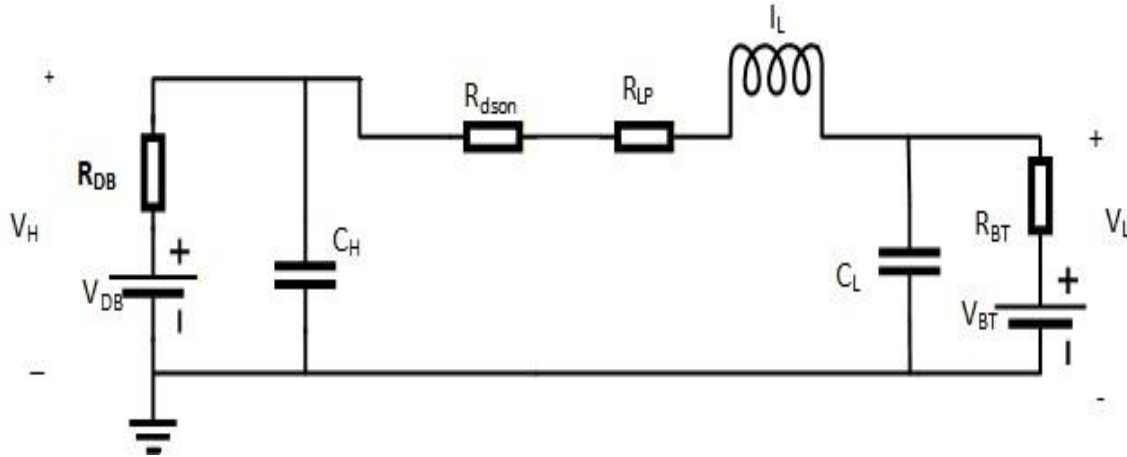

Fig.4.3.Buck mode circuit topology

Step-down operational mode consists of Q_1 and D_2 conduction while Q_2 and D_1 remain off. When switch D_2 is ON and all others remain OFF, the inductor L and output capacitor C_L are charged from the bus voltage. When Q_1 and Q_2 are both OFF, diode D_2 acts as a freewheeling diode. Since the inductor current I_L cannot change instantaneously, it is discharged through D_2 , so the output voltage across load R_{BT} decreases compared to the input supply voltage.

Using KVL and KCL:

Inductor current i_L :

Apply KVL on inductor loop

$$L \frac{di_L}{dt} = V_H - V_L - R_{BT} i_L \quad (4.8)$$

So,

$$\frac{di_L}{dt} = \frac{1}{L} (V_H - V_L) - \frac{R_{BT}}{L} i_L \quad (4.9)$$

High side capacitor voltage V_H :

Apply KCL at Capacitor C_H

$$C_H \frac{dV_H}{dt} = \frac{V_{DB} - V_H}{R_{DB}} - i_L \quad (4.10)$$

$$\frac{dV_H}{dt} = \frac{1}{R_{DBC_H}} (V_{DB} - V_H) - \frac{1}{C_H} i_L \quad (4.11)$$

Low side Capacitor Voltage V_L :

Apply KCL at Capacitor C_L :

$$C_L \frac{dV_L}{dt} = i_L + \frac{V_{BT} - V_L}{R_{BT}} \quad (4.12)$$

$$\frac{dV_L}{dt} = \frac{1}{C_L} i_L + \frac{1}{R_{BT}C_L} (V_{BT} - V_L) \quad (4.13)$$

$$\begin{bmatrix} \dot{I}_L \\ \dot{V}_H \\ \dot{V}_L \end{bmatrix} = \begin{bmatrix} -\frac{R_{BT}}{L} & \frac{1}{L} & -\frac{1}{L} \\ -\frac{1}{C_H} & -\frac{1}{R_{DBC_H}} & 0 \\ \frac{1}{C_L} & 0 & -\frac{1}{R_{BT}C_L} \end{bmatrix} \begin{bmatrix} I_L \\ V_H \\ V_L \end{bmatrix} + \begin{bmatrix} 0 & 0 \\ 0 & \frac{1}{R_{DBC_H}} \\ \frac{1}{R_{BT}C_L} & 0 \end{bmatrix} \begin{bmatrix} V_{BT} \\ V_{DB} \end{bmatrix} \quad (4.14)$$

4.2.4 Boost mode (step up operational)

Switches Q_2 and Q_1 stay off in this state, but switch Q_2 stays on. Thus, power moves from the battery to the side of the load. As a result, the battery discharges and provides high-voltage electricity to the load end.

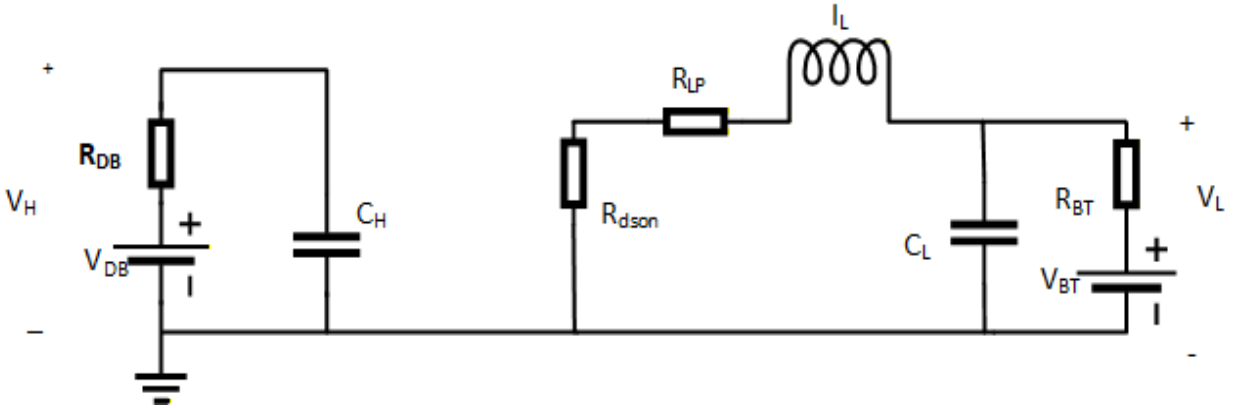

Fig.4.4.Boost mode circuit topology

In this mode, electricity is transferred from the battery to the load side by keeping switch Q_2 ON and switch Q_1 OFF. In order to provide high-voltage electricity to the load, the battery drains. Q_2 and D_1 conduct while Q_1 and D_2 stay off in step-up operating mode. When Q_2 is first turned on and the battery source charges the inductor, I_L rises linearly. The circuit is deemed open in the

second step since both Q_2 and Q_1 are turned off. Diode D_1 becomes forward biased because the voltage across the inductor current reverses since the polarity of the current cannot change instantly. When compared to the input supply voltage, the output capacitor C_L is charged to a higher voltage by the inductor current.

According to the circuit topology, boost mode mathematical expression

Using KVL and KCL

By KVL on inductor

$$L \frac{di_L}{dt} = -R_{BT}i_L - V_L \quad (4.15)$$

So,

$$\frac{di_L}{dt} = \frac{-R_{BT}i_L}{L} - \frac{1}{L}V_L \quad (4.16)$$

High Voltage capacitor V_H :

By KCL at capacitor C_H ,

$$C_H \frac{dV_H}{dt} = \frac{V_H - V_{DB}}{R_{DB}} \quad (4.17)$$

$$\frac{dV_H}{dt} = \frac{1}{R_{DB}C_H}V_H + \frac{1}{R_{DB}C_H}V_{DB} \quad (4.18)$$

Low voltage capacitor V_L :

By KCL at capacitor C_L ,

$$C_L \frac{dV_L}{dt} = i_L + \frac{V_{BT} - V_L}{R_{BT}} \quad (4.19)$$

$$\frac{dV_L}{dt} = \frac{1}{C_L}i_L - \frac{1}{R_{BT}C_L}V_L + \frac{1}{R_{BT}C_L}V_{BT} \quad (4.20)$$

$$\begin{bmatrix} \dot{I}_L \\ \dot{V}_H \\ \dot{V}_L \end{bmatrix} = \begin{bmatrix} \frac{R_{BT}}{L} & 0 & \frac{1}{L} \\ 0 & -\frac{1}{R_{DB}C_H} & 0 \\ \frac{1}{C_L} & 0 & -\frac{1}{R_{BT}C_L} \end{bmatrix} \begin{bmatrix} I_L \\ V_H \\ V_L \end{bmatrix} + \begin{bmatrix} 0 & 0 \\ 0 & \frac{1}{R_{DB}C_H} \\ \frac{1}{R_{BT}C_L} & 0 \end{bmatrix} \begin{bmatrix} V_{BT} \\ V_{DB} \end{bmatrix} \quad (4.21)$$

4.3 Summary

The study of this chapter involved an investigation of the basic concepts and modeling of the DC-DC converters that are employed in EV charging systems. Different kinds of converters including buck, boost, and buck-boost converters were discussed with their working principles and the equation for voltage transformation. Next, mathematical modeling of the non-isolated half-bridge bidirectional DC-DC converter was done using state-space representation.

CHAPTER 5

BATTERY TYPES

5.1 Battery Types in EVs

Based on their capacity to be recharged, batteries are frequently divided into two groups: primary and secondary batteries. The secondary battery can be recharged once completely depleted, while the primary battery can only be used once. A secondary battery with a long cycle life, low energy loss, high power density, and sufficient safety level is essential for EV and HEV applications. Lead acid, nickel-cadmium (NiCd), nickel metal hydride (NiMH), and lithium-ion (Li-ion) batteries are among the common battery types used in EVs. Some important features of these common battery types are shown in Table.5.1. Li-ion batteries are clearly superior to other popular battery types in EVs (Table.5.1). battery types, especially with regard to large cycle life, which is necessary for EVs to have a long service life (e.g., 6–10 years). Li-ion batteries also have a high level of safety and are composed of components that are safe for the environment and do not produce hazardous gases. Li-ion batteries are currently the most popular EV power source as a result.

5.2 Key Technologies for BMS

However, in EV applications, batteries require special attention. Battery deterioration will be significantly increased by improper operations, such as overcharging, discharging, or extremely high or low temperatures. A suitable BMS must be appropriately constructed to avoid batteries from being damaged because operating such a complicated battery pack necessitates extra vigilance. Fig.5.1 shows how these important technologies are related. On-board current and voltage sensors may immediately detect battery current and voltage in EV applications, while thermocouples or temperature sensors can simply measure the battery pack's surface temperature. Finally, using well-trained battery models along with suitable estimation algorithms, independent or combined state estimations of battery state-of-charge or internal temperature can be achieved. After collecting information regarding electrical and thermal behaviour of the battery, suitable battery charging methods can be developed through applying proper optimization algorithms.

All the abnormal operating conditions of the battery will be recorded and handled by the alarm and safety control modules. Therefore, the modelling of batteries, state estimation, and control of batteries are some of the most important BMS technologies, and many researchers are focusing on their development. Table.5.1 Comparison of Different Battery Types for EV Applications

5.2.1 Comparison of Different Battery Types

Table 5.1 shows the comparison of batteries

Battery type	Service life/cycle	Nominal voltage /V	Energy density (Wh·kg ⁻¹)	Power density (W·kg ⁻¹)	Charging efficiency/%	Self-discharge rate (%·month ⁻¹)	Charging temperature/°C	Discharging temperature/°C
Li-ion battery	600–3000	3.2–3.7	100–270	250–680	80–90	3–10	0 to 45	–20 to 60
Lead acid battery	200–300	2.0	30–50	180	50–95	5	–20 to 50	–20 to 50
NiCd battery	1000	1.2	50–80	150	70–90	20	0 to 45	–20 to 65
NiMH battery	300–600	1.2	60–120	250–1000	65	30	0 to 45	–20 to 65

Comparison of various rechargeable batteries utilized in electric vehicle (EV) applications is given in Table 5.1. Important properties of the batteries that were considered

Li-ion batteries outperform all other battery technologies when all these properties are considered. High energy density in the range of 100-270 Wh/kg and high-power density in the range of 250-680 W/kg are exhibited by Li-ion batteries. Also, Li-ion batteries have good service life, high

charging efficiency, and low self-discharge rate, thus making them extremely useful for EV charging applications.

Lead acid batteries have low energy densities and short cycle life than new battery technologies. Even though they are cheap and have easy maintenance, they are too heavy and less efficient and therefore do not make suitable light-weight EV batteries. The Nickel-Cadmium (NiCd) batteries have medium energy densities and medium cycle lives. Nonetheless, these batteries have relatively high self-discharge and are not environmentally friendly owing to their poisonous content of cadmium. The Nickel-Metal Hydride (NiMH) batteries have increased energy and high-power densities than the Nickel-Cadmium batteries. They are environmentally friendly but have high self-discharge and poor efficiencies compared to the lithium-ion batteries.

From the above discussion, it can be noted that the Lithium-Ion Batteries perform better in terms of energy density, efficiency of charge, cycle life, and weight issues. This is the reason why they are preferred to other types of batteries.

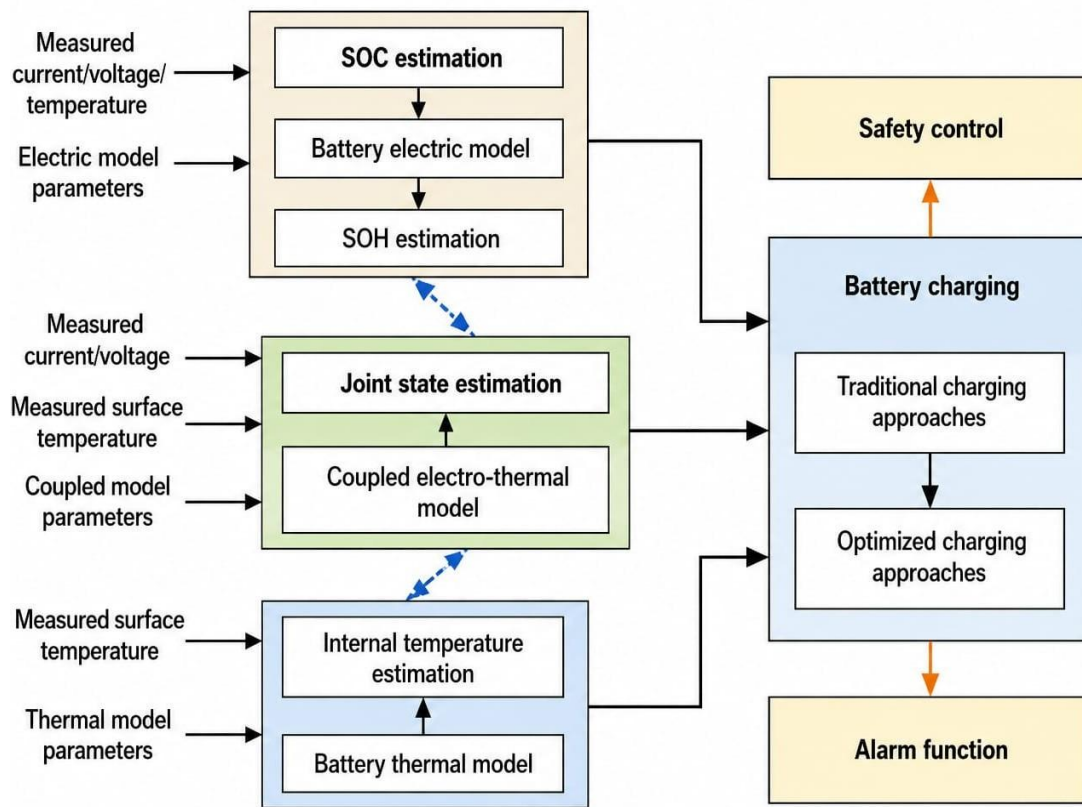

Fig.5.1. The relationship between the BMS's major technologies [39]

5.3 Battery Modelling

The designing, controlling, and refining of the BMS begins with developing an appropriate model of the battery system. There are many such models with different accuracies and complexities available. These types of models can generally be classified into three main types – battery electrical models, battery thermal models, and battery link models. Fig. 6.1 deals with these models.

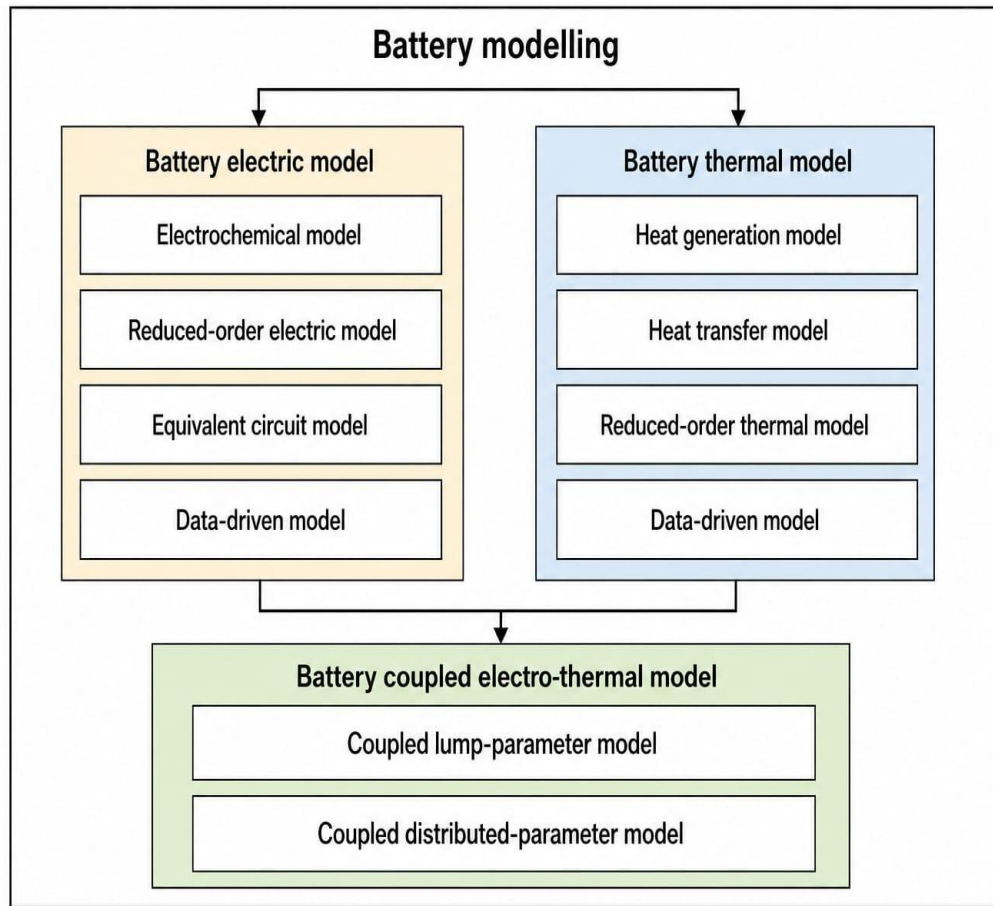

Fig.5.2 Three battery modeling classes [39]

5.3.1 Battery Electric Model

Data-driven model, equivalent circuit model, reduced order model, and electrochemical model are the four types of electric models used to describe batteries. An electrochemical approach for modeling the electrode potential of every phase is said to have been attained whereas Butlerville’s kinetics account for the intercalation process and the spatiotemporal distribution of battery concentration. Finally, an electrochemical model for the batteries is built on the basis of improved parameters of the model via the application of PSO method. Finally, a methodology was

established to implement the electrochemical model into the BMS, which stated that the electrochemical model of a battery must include the electrode potential of every phase, spatio-temporal dynamics of battery concentration, and Butler-Volmer kinetics to control the intercalation reaction. An electrochemical model is then created to explain the electrochemical behaviors of batteries by utilizing the particle swarm optimization (PSO) technique to improve key model parameters. showed that, despite the electrochemical model's excellent prediction ability, model simulation needed a lot of processing power.

The possibility of giving a relatively accurate account of the electrochemical reactions in the battery is one of the main benefits of using an electrochemical model that was incorporated into the battery management system using the model implementation technique. However, certain parameters related to the electrochemistry of batteries cannot be measured at the same time while using a battery. Significant processing overheads result from the fact that these electrochemical models usually need the solution of many partial differential equations. With the right assumptions, reduced-order models can mimic full-order electrochemical models. For example, after developing a simplified approach for describing the solid phase diffusion and electrolyte concentration distributions within batteries, a fundamental physics-based electrochemical model for estimating the state of charge (SOC) of Li-ion batteries can be established. A Reduced order electrochemical battery model of the LiFePO₄ battery system was proposed to calculate the discharge capacity in different scenarios. Accurate SOC estimation was achieved using the developed battery model. Measured voltage and current data can be utilized to calculate the related parameters and reduced-order models require significantly less computation cost. In case of equivalent circuit models, electric properties of batteries are obtained in terms of resistance, capacity, and other circuit elements.

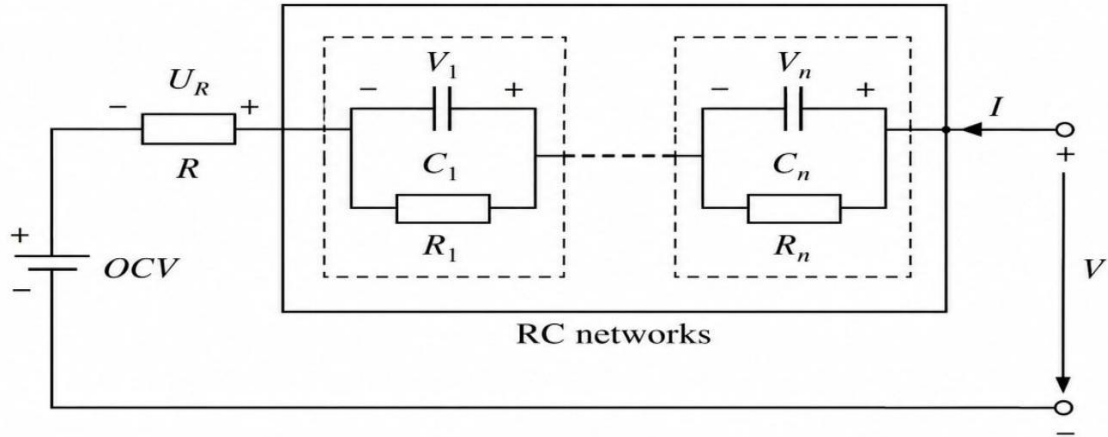

Fig.5.3 Battery circuit diagram

5.3.2 Battery Thermal Model

Due to the influence of temperature on the performance and life of batteries, temperature and thermal behavior play a crucial role in the BMS of electric vehicles. There are many types of models employed to characterize the thermal behavior of batteries, such as data-driven model, reduced order thermal models, heat generation models, and heat transfer models. Several techniques such as activation, concentration, and ohmic losses which distribute unevenly in the battery are considered in the heat generation models.

5.3.3 Battery Coupled Electro-Thermal Model.

A strong relation can be seen between electric processes in the battery and its temperature. To measure simultaneously electric properties (like current, voltage, and state of charge) and thermal properties (including surface and internal temperature) of the battery, some kinds of electro-thermal models which include lump parameter models and distributed-parameter models have been proposed in the literature. Moreover, an electro-thermal 3D model was designed to predict SOC of battery and calculate heat production. This coupled model includes a 2D model for potential distribution and a 3D model for temperature distribution in the battery. Then, by using this combined model, it is possible to precisely estimate the battery SOC and temperature distributions under constant and variable current conditions. Another simplified model for low temperatures was verified on three types of batteries with different cathode materials. In cases where the temperature is lower, this simple model suffices in finding the correct charge process

and quick heat up. an electro-thermal 3-D model to investigate the effects of various battery operations like coolant flow and discharge currents on its temperature.

5.4 Summary

The chapter focused on various types of battery technologies for electric cars. In particular, lead acid, nickel-cadmium (NiCd), nickel-metal hydride (NiMH), and lithium-ion (Li-ion) batteries were analyzed. A comparative analysis was conducted, indicating the advantages of Li-ion batteries due to their energy density, charge efficiency, longevity, and lightweight characteristics. The current chapter also considered the need for Battery Management System (BMS) in monitoring battery safety, state of charge (SOC), and thermal conditions. Moreover, various battery modeling approaches such as electric models, thermal models, and coupled electro-thermal models were outlined.

CHAPTER 6

BATTERY CHARGING APPROACHES

6.1 Charging Approaches

The discharge needs to stop, and the battery must be charged after the source of energy runs out. Either its state of charge falls below 20% or its terminal voltage falls below the cut-off voltage. Table 6.1. displays the charging performance for different batteries. Overdischarging, overcharging, or inappropriate charging are examples of incorrect actions that will significantly accelerate the battery's deterioration process. The Li-ion battery performs very steadily when compared to other battery types, although it has a shorter cycle life at high temperatures and cannot be charged below freezing. Accurate battery SOC, SOH, and temperature estimates allow for the effective design of appropriate battery charging strategies, which in turn enable the battery to be charged from its starting state to its final SOC goal value. In meantime, charging techniques can increase capacity usage, extend battery life, and prevent overheating.

6.1.1 Traditional Battery Charging Approach

The four traditional charging approaches that have been traditionally applied for the purpose of charging EV batteries are given in Fig. 6.1. These four major categories include the multi-stage constant current (MCC), constant voltage (CV), constant current-constant voltage (CC-CV), and constant current (CC) charging processes. These two techniques, CCCV and MCC, have been highlighted here. However, the technique for CC charging, whereby batteries are charged using a small constant current rate, is very simple, but rough. Performance of different batteries while charging Li-ion batteries NiMH, NiCd, and lead acid CC charging CV charging Conventional methods for charging MCC and CC-CV charging. Conventional battery charging methods in EVS throughout the entire charging procedure. The CC charging is halted when the time-to-charge reaches a predefined threshold. Although it is also commonly used for Li-ion batteries, this charging technique was first created for NiCd or NiMH batteries.

Because batteries performance depends on how fast the current flows into the battery, it will be very difficult to use the constant current charging method because of the problem of choosing the

right charging current. While high CC charging current rates increase charging speed, they also hasten the battery's aging process. A moderate current rate in CC charging allows for high-capacity utilization, while a very low current rate can slow down battery charging and further diminish the ease of using an EV. CV charging, which fully charges batteries with a fixed constant voltage is another straightforward conventional charging method. Avoiding overvoltage and irreversible side reactions during the charging process is the main benefit of employing CV charging to extend the battery's cycle life. The poor acceptance with CV charging will cause the charging current to steadily decrease.

But this technique needs high charging current to ensure consistent terminal voltage at the beginning of charging and this can cause battery lattices to break down and battery pole to be fragmented. Selection of right constant voltage for a suitable compromise between charging rate, electrolysis, and effective utilization of the capacity is yet another problem associated with the CV charging approach. This is because CV charging has a disadvantage in that even though it greatly improves charging rate, it greatly decreases battery capacity. The cause of this is that as the battery capacity decreases, the charging current increases dramatically. This causes battery lattice framework to become collapsed and pulverization of active material of battery pole to become more pronounced. But with increased battery capacity, the charging current becomes substantially reduced. This technique of charging is considered relatively fast due to the high average value of current in batteries at SOC between 0.15 and 0.8. There will be only a minor reduction in the charging current of the CV technique as SOC comes near 0.9. By combining CC and CV techniques of charging, another technique of hybrid nature has been proposed which is called CC-CV. Under this technique, first, a constant current charging of the battery takes place by keeping the current value fixed. Then there is an increase in the battery voltage to its maximum safety limit.

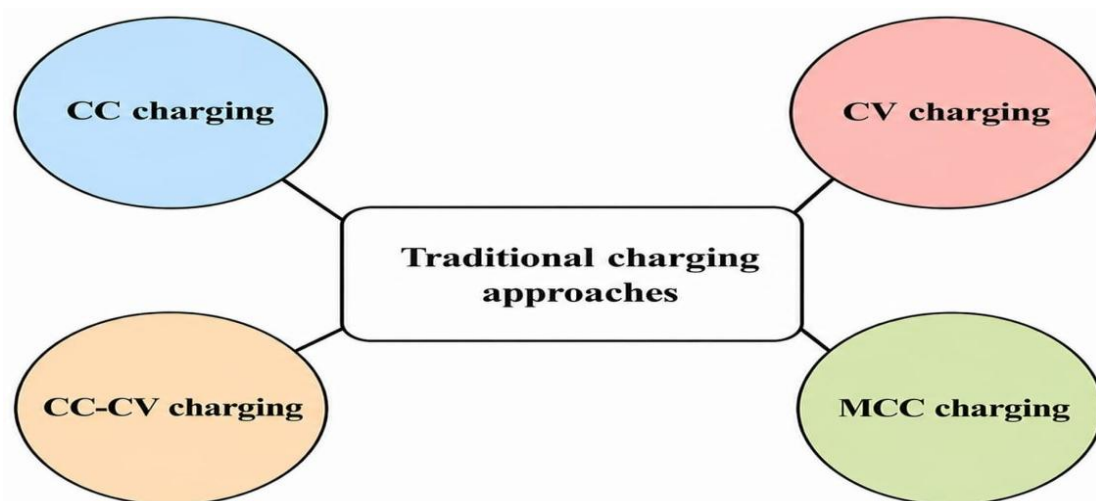

Fig.6.1. Traditional charging approaches for battery in EVs

Table.6.1. Battery type and its charging performance

Battery type	Charging performance
Li-ion	1) While high temperatures can speed up charging, they shorten battery life. 2) It is risky to charge at temperatures that are significantly below freezing.
Lead acid	1) The V-threshold decreases by 3 mV/°C at higher temperatures. 2) charging below freezing by 0.3 C or less
NiMH, NiCd	1) At 45 °C, charging acceptability is 70%; at 60 °C, it is 45%. 2) A charging rate of 0.1 C between -17 °C and 0 °C 3) 0.3C charging between 0 and 6 degrees Celsius

By merging CC and CV charging, a hybrid charging approach known as CC-CV has been put forth. This technique uses a fixed constant current in the CC phase to first charge a battery. After that, the battery voltage increases to the maximum safe level. After then, the battery enters the CV

phase, when the charging current is continuously stepped down at a fixed constant voltage. This CV phase will end when either a goal capacity or a terminal value of the falling current is reached. Lead acid batteries are initially charged using the battery manufacturer's recommended preset values of constant current and constant voltage in the traditional CC-CV Approach. It can also be used to charge Li-ion batteries with a few tweaks. Because Li-ion batteries have higher terminal voltage and charge acceptance than lead acid batteries, which are typically chosen between 0.5 and 3.0 C, the constant current in Li-ion battery CC-CV charging applications should be much larger. The CC-CV charging process's CC and CV phases can be complementary in some way; the CV stage will effectively counteract the capacity loss caused by the CC stage's high electrochemical polarization. Because it is better than both sole CC and sole CV charging in EV applications, the choice of the CC-CV charging technique has been made as a standard against which other new battery charging techniques will be evaluated. Even though the basic CC-CV charging technique is relatively simple to use, determining the proper current and voltage levels in the CC and CV processes, respectively, can be quite difficult. The constant current rate is the main factor influencing battery charging speed in the CC-CV approach, even if the constant voltage and termination values have a significant impact on battery charging capacity usage. On the one hand, a high current rate in CC-CV may result in lithium plating and low energy conversion efficiency. On the other hand, battery temperatures may rise over acceptable limits, particularly in high power applications.

Conversely, low charging current can slow down battery charging and make using EVs less convenient. Therefore, to ensure battery operating safety and enhance overall charging performance, a good CC-CV strategy must be designed. MCC charging is another well-liked conventional charging method. This method has been effectively designed to charge several battery types, including Li-ion, NiMH, and lead acid batteries. The multi-stage series of monotonic charging currents that are injected into the battery during the whole charging process is the primary distinction between CC-CV and MCC charging. As several phases of constant currents (I_{cc1} I_{cc2} ... I_{ccN}), this sequence of charging currents should be progressively decreased. The new charge level, which will not be completely constant, will be employed according to the new charge process when the terminal voltage reaches the default level due to the constant current charge. This lowers the charging current process, which will continue until the battery terminal voltage, under the minimum current situation, achieves the final default voltage threshold. With the same starting

current, the regular MCC technique will often charge a little more slowly than the standard CC-CV approach.

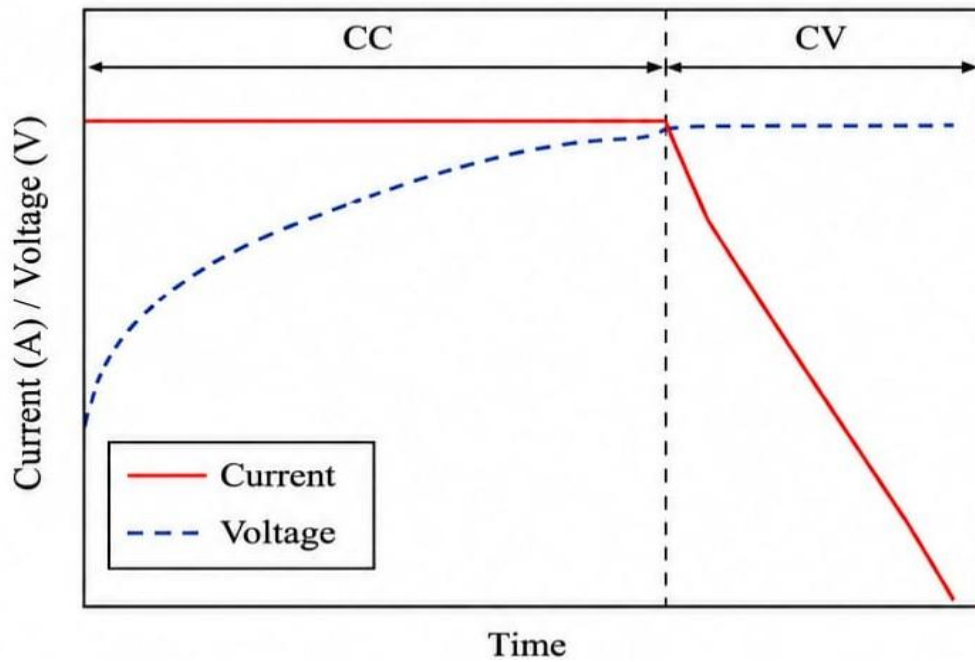

Fig.6.2. The CC-CV charging method's battery voltage and current

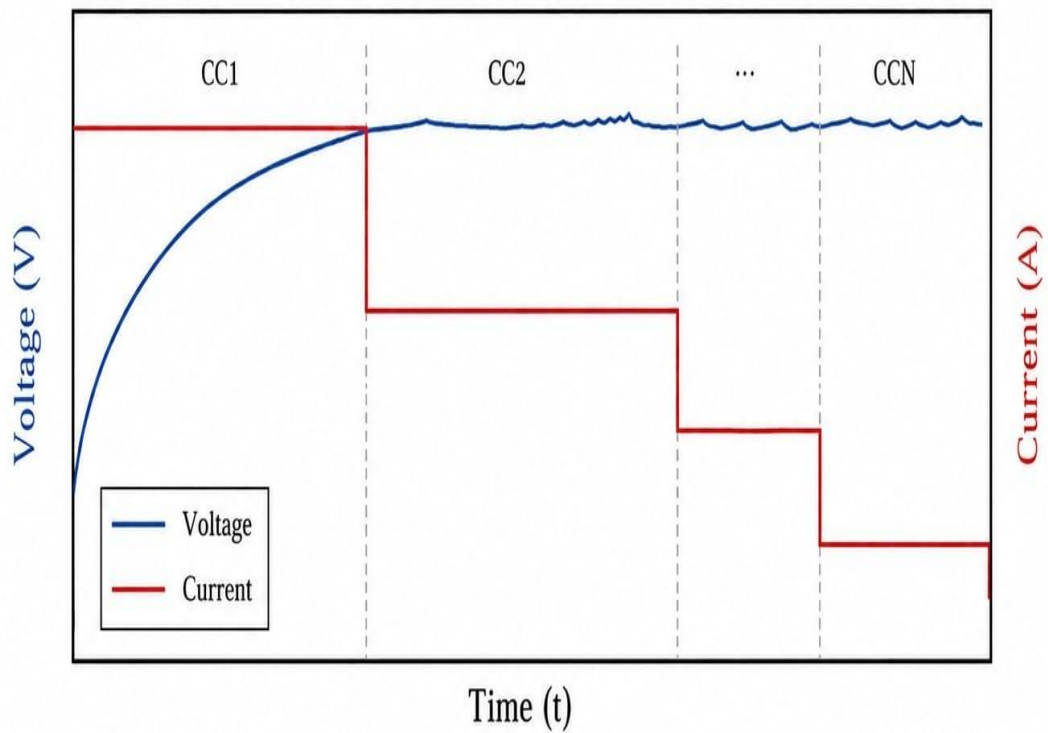

Fig.6.3. The MCC charging method's battery voltage and current

Table.6.2. Comparing conventional methods for EV battery charging

Approach	Advantages	Disadvantages	Key elements
CV	1) Simple to use. 2) steady voltage at the terminal	Battery lattice collapse can easily cause.	1) Consistent voltage charging. 2) terminal state
CC-CV	1) High usage of capacity. 2) constant voltage at the terminal	It can be difficult to balance objectives like temperature change, energy loss, and charging speed.	1) The CC phase has a constant current rate. 2) steady voltage during the CV phase. 3) final state
MCC	1) Simple to use. 2) Quick charging is simple to do	Balancing goals like battery lifetime, capacity use, and charging speed can be challenging.	1) The quantity of CC phases. 2) consistent current rates for every phase

A brief comparison between the conventional charging methods discussed above is presented in Table. 6.2, along with a brief discussion about their merits, demerits, and essential components. Simple methods like single CC charging method and CV charging cost less to implement and require few parameters. There are some combination techniques of charging that seek to improve performance such as rapid charging, minimizing overcharging, and efficient capacity utilization. The biggest challenge associated with hybrid charging technique is finding out the most suitable current and voltage levels for charging to strike a balance between conflicting interests like rapid charging, heat dissipation, etc.

6.1.2 Battery State Estimation

The battery states that are important include internal temperature, joint state of estimation, SOC, and SOH. The portion of the capacity that is still available in the battery under the same conditions is termed SOC estimation. If the battery is at 100%, then it indicates that it is fully charged to its maximum capacity, and when the battery is at 0%, then it indicates that the battery is completely discharged. For a safe and healthy operation of the battery, SOC estimation needs to be done accurately. There are two approaches that have been developed for SOC estimation; they include

the model-based method and the direct estimation method. The Ampere hour (Ah) method and the OCV-based method are the two techniques used for calculating SOC using the direct estimation method.

Since the discharge/charge current could be easily measured, it would be convenient to use the Ah method for estimating SOC. Since the Ah algorithm relies heavily on current readings, the accumulated error could have a great effect on the result of estimation. Moreover, it is difficult to establish the initial SOC since the current value might not be constant during charging since the battery is charged to a certain level, like from 10% to 90%, for instance. Calibration of the initial SOC and current would be the difficulty of applying the Ah technique to SOC calculation. One-to-one non-linear relationship has been proposed to represent the correlation between SOC and OCV. As a result, OCV-based SOC estimation, which becomes possible after battery rest, is considered to be a popular technique used successfully in many real-world applications. The rest time has become the main obstacle in calculating battery SOC based on OCV. Although OCV could provide a high degree of SOC measurement precision, some drawbacks make its application difficult. It takes a certain amount of time for battery to achieve a steady state after loading was cut (at low temperatures, it took over two hours to recharge a LiFePO₄ battery, for example).

The OCV method's limitations prevent it from being widely used in EVs. If the OCV can be received in real-time to enable SOC estimation while driving, this issue can be resolved. In order to further accomplish online battery SOC estimation, a model-based method for calculating OCV has been created. A good battery model must be carefully created in model-based approaches. Battery SOC is typically estimated using battery equivalent circuit models and electrochemical models in the forms of standard state space, where SOC is one of the state variables.

6.1.3 SOH Estimation

SOH is another important indicator of battery performance that is visible at the cell or pack level. SOH predicts how many times the battery can be charged and depleted before its life is over. The EMS uses this information to make decisions on how to extend battery life while also making arrangements for battery replacement. Once more, it is not possible to measure SOH directly from the battery terminals. Additionally, a precise definition of SOH is required. A lot of work is

currently being done to investigate battery SOH, especially online SOH estimation for EVs and smart grid applications.

6.1.4 SOC Estimation Algorithms

To estimate the SOC from the battery's available readings, a number of methods and techniques have been put forth. One of the most popular techniques is Coulomb counting, also known as Ah counting, in which the amount of charge released from or held in the battery is calculated using a time integral of the terminal current and compared to the battery's full charging capability. Although this method is easy to design, it is constrained by the unknown starting value of the SOC and a current sensor error that accumulates over time as a result of the integration process. Another method for determining the SOC based on the static relationship between the OCV and the SOC is to measure the open circuit voltage. To improve the accuracy of the SOC estimation, this technique can be applied separately or in conjunction with Coulomb counting. However, in order to acquire the OCV, the battery must be at rest—that is, without charging or discharging—for an extended period of time, sometimes up to eight hours or longer—due to the long-term battery dynamics.

For online applications, like EVs, this requirement circumvents this approach. In a similar vein, another method for estimating the SOC is electrochemical impedance spectroscopy (EIS). By delivering tiny current pulses at various frequencies to the battery and using specialized EIS analyzer equipment to measure the accompanying voltage, the internal impedance of the battery may be determined. However, this procedure is only appropriate for offline analysis because it takes a lengthy time. Online techniques have recently been created and gained popularity, such as model-based SOC estimate algorithms. The battery's dynamics are represented as a system that is inherently nonlinear. A variety of methods are used to create observers to track the system's state of control (SOC). These methods range from basic observers created by trial and error to sophisticated resilient, optimum, and recursive methods (such as sliding mode observers and Kalman filters). These approaches are all dependent on offline identification of the battery model parameters, even though the latter yields more reliable and precise results. The experimental and analytical findings of modeling numerous batteries at varying SOC and environmental conditions are in conflict with the constant parameters for the battery model found offline. When the SOC shifts between 0 and 100%, certain battery model parameters can change by up to 800% at the

same temperature and discharging current rate. Battery Dynamometer Torque Speed PC LabVIEW GUI parameters/SOC co-estimation is one of the recently presented techniques by ADAC that uses an adaptive online parameter-identification algorithm to identify and update the model's parameters while estimating SOC based on a basic battery dynamics model. The parameters are then continuously updated to appropriately represent all of the battery's static and dynamic characteristics by using a piecewise linearized mapping of the OCV–SOC curve. An observer is created based on an updating model to estimate the battery's state of charge (SOC), since it is one of the battery model's states. The battery model's parameters must be updated during SOC calculation in order to improve estimation accuracy and prevent needless correction for uncertainties, according to both simulated and experimental data.

6.1.5 SOH Estimation Algorithms

The SOH estimation method is incorporated in the proposed light EV charging system with the help of the DC–DC converter. These important parameters of the battery, which include battery voltage, charging current, battery temperature, internal resistance, and capacity, continue to be monitored by the algorithm. The parameters are analyzed and used in determining the degradation state and useful life left of the battery. With age, the amount of charge that the battery can store diminishes while its internal resistance increases.

The SOH of the battery is calculated using the following expression:

where:

$Q_{present}$ is the present battery capacity

Q_{rated} is the rated battery capacity

First, the voltage and current sensors take measurements of the working conditions of the battery. These values are fed into the controller, where the estimation of the battery capacity and the charge status is done. Comparison of the values with the standard values allows detecting the degradation of the battery. In case of SOH value being lower than a certain limit, the system makes changes in the charging current and operation of the converter, thus providing protection of the battery from overloading and overcharge. The calculated value of SOH is utilized for intelligent energy management and safe operation of the EV charging system.

The suggested approach to SOH calculation offers an efficient way of battery status monitoring that increases the life span of the battery, ensures safe charging process, and contributes to improved performance of the light-weight EV charging.

6.2 Summary

The above chapter covered various types of battery charging technologies for use in electric vehicles. This included the significance of appropriate battery charging technology in enhancing battery durability and efficiency. The pros and cons of each technology were outlined, particularly in terms of efficiency of charge transfer, battery safety, heating, and battery capacity. The chapter concluded that CC-CV is the ideal form of battery charging technology because it offers the best balance in the above attributes.

CHAPTER 7

OPTIMIZATION OF BATTERY CHARGING

APPROACHES

7.1 Charging Performance of Batteries

To enhance the charging performance of batteries in EVs, numerous optimized charging techniques have recently been developed based on the conventional standard charging. These charging technique optimizations fall into four categories.

7.1.1 CV Charging Optimization

The first area is CV charging optimization. To improve the charging performance of conventional CV charging, a few strategies have been implemented. These methods consider objectives like temperature change and charging speed. To reduce battery temperature fluctuation, a constant voltage with different limiting current strategies is offered. Modulating the suggested approach's current rate results in a low battery temperature rise during the entire charging operation fast-charging control strategy for MCC and CV charging optimization.

7.1.2 CC-CV Charging Optimization

Charging optimization through CC-CV method is one of the possible charging approaches used for electric vehicles. Based on the inner resistance of the batteries, the control system provides a higher charge rate of the battery in comparison to the standard charge rate of the CV approach. Many scientific articles have been written regarding improvements of charging behaviour of the batteries using CC-CV or MCC approaches because of their simplicity and efficiency. Thus, it is possible to state the feasibility of presenting a methodology of improving CC-CV/MCC charging. The most critical factors associated with ideal CC-CV charging are the CV value and the current rate in the CC stage.

7.1.3 Improved CC- CV Charging Optimization

Recent years have witnessed much research works that improve the CC-CV charge technique. An improved battery charger model that includes the cycle control algorithm with zero computation is proposed to improve the CC-CV profile of Li-ion batteries. It has been proven that this enhanced battery charger successfully operates the CC-CV charge scheme. To derive the optimal CC-CV charge scheme for a Li-ion battery, a closed-form algorithm is proposed. Based on the temperature increase, energy loss, and charging time, the cost function determines the optimized CC-CV charging profile. A controller is used to improve the performance of Li-ion batteries when using CC-CV charge schemes. Sense and charge modes are utilized instead of ordinary CV mode.

The faster charging approach will be realized at this point. This is with respect to a model related to thermoelectricity and that is used to describe three objectives in a battery charging cost function which include: time taken to charge the battery, energy loss during charging process and rise in temperature.

7.1.4 TLBO Based Charging Optimization

Here, the optimal CC-CV approach in relation to Li-ion battery charging is determined through balancing of three conflicting objectives using the teaching learning-based optimization (TLBO) approach. With a view to optimizing the CC-CV approach to Li-ion battery charging, a model-based approach was adopted.

Next, the present regions which can achieve such important goals are specified through maximizing the capacity of the Li-ion battery with cell-aware charging technique. It is an extended form of the typical CC-CV charge scheme, which starts with CC charge and continues until reaching a certain threshold voltage. Following that, the battery will be charged at another voltage level until the current reaches its cut-off value. In addition, the PLL control technique is applied for improving the CC-CV charging system performance. A current pumped battery charger (CPBC) with PLL-CC-CV technique is proposed for enhancing the charging efficiency of Li-ion batteries.

7.1.5 MCC Charging Optimization

The main task in MCC charge optimization, which is also the most difficult one, is determining the number of current stages in the MCC profile and current rates for each CC stage. One of the most widely used techniques in C2 charge optimization is fuzzy logic technology. Using fuzzy logic controller, two charge quality parameters (normalized discharge capacity and charge time) are represented by a single fuzzy dual-response performance index. To improve charging performance, a five-stage M^{21} charge algorithm is modified. The weights in the fitness function of lithium-ion charging are manipulated via fuzzy logic control. Then, using the suggested fitness function of fuzzy logic, the PSO algorithm may be applied to maximize the best MCC charging profiles. One more important technique is the identification of optimal MCC charging plan based on Taguchi method. This is the Taguchi method for extending cycle life and increasing the charge rate of a Li-ion battery. The sequential orthogonal array approach is employed to optimize a five-stage MCC charge algorithm. A four-step charge strategy for the MCC is proposed using the Taguchi method along with the SOC estimation in order to minimize the difference in the battery temperature, charge speed, and efficiency of energy conversion. Besides, other techniques are also available, such as function modeling approach or ant colony algorithm.

It is employed to improve the efficiency of the MCC charging method. a charging approach for the MCC, which attempts to solve the conflicts between the charging speed and energy dissipation in the process by applying various weighting methods depending on the internal DC resistance model. Proposes a new technique which employs the concept of an equivalent circuit in determining the optimum M^{21} charging procedure for Li-ion batteries. With respect to the best technique, three stages and five stages of constant currents are analyzed based on their contribution toward increasing charging efficiency and speed. A Taguchi approach to improve the cycle life and speed up the charging of a Li-ion battery. A four-stage MCC charging procedure is suggested using the Taguchi methodology in combination with the SOC estimation for addressing trade-offs between variations in battery temperature, charging time, and energy efficiency. The other methods are ant colony system, model, and function. It is applied for improving MCC charging. A MCC charging scheme that resolves contradictions between fast charging and power dissipation in the charging cycle through application of different weight factors during various stages in accordance with an internal DC resistance (DC: Direct Current) model. A novel approach for determining the

optimal M^{21} charging scheme for Li-ion batteries using the equivalent circuit model. The analysis is conducted of the three and five CC stages based on the optimal pattern. Conclusively, the amount of CC stages involved, and the current at which these processes take place has a very significant effect on aspects like charging time, energy losses, and efficiency of the overall MCC charging process.

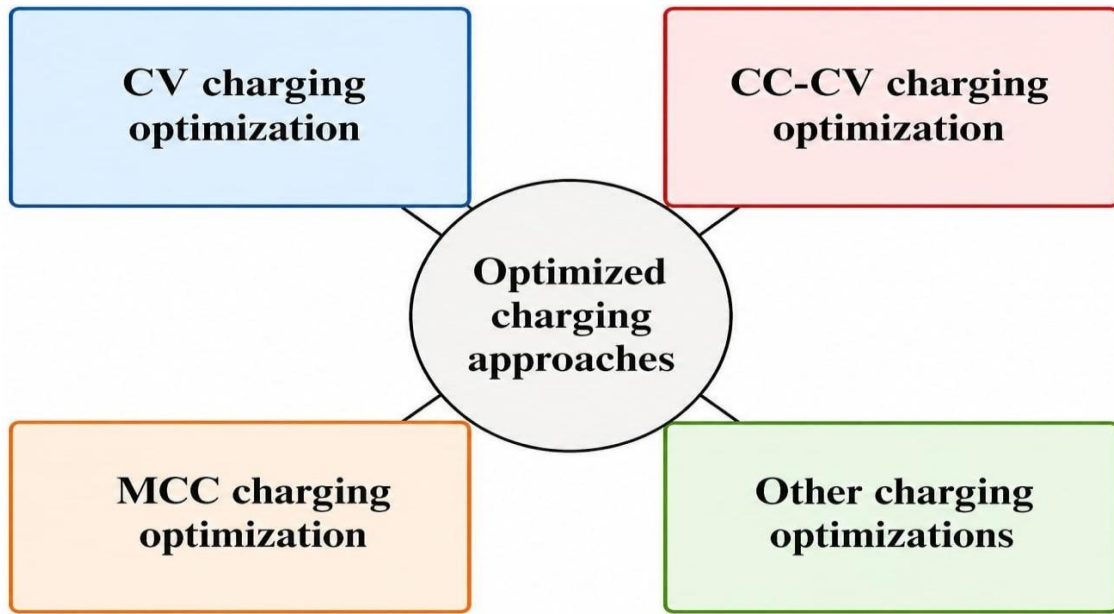

Fig.7.1 Optimized charging approaches

As no voltage limit is required for the MCC charge, it becomes inexpensive to deploy. Apart from improving the traditional methods, certain new methods of charging also have been suggested. All these methods were developed using computational intelligent approaches like dynamic programming (DP), and pseudo spectral optimization.

7.1.6 Dynamic Programming Techniques

DP is commonly employed for finding the optimal battery charge algorithm for an applicable battery model. The most flexible way for identifying the battery charge is through the DP method, because it considers the nonlinearity and variability of battery models. It can be because the DP algorithm solves small problems and finds an optimal solution based on their combination.

However, DP frequently requires the storage of a huge amount of data, which results in high computation costs, particularly in high dimension charging situations. A proper battery model must also be designed for the MPC-based charging methods. MPC can also effectively solve hard battery

restrictions during the entire charging process. However, more research is required to increase forecast accuracy about the effects of battery temperature and age on battery model parameters.

However, evolutionary algorithms typically have excessively high processing costs. The parameters and appropriate evolutionary algorithm must be chosen empirically by researchers. In actual battery charging applications, pseudo-spectral optimization-based battery charging is another well-liked and efficient technique. Pseudo-spectral optimization can consider a wide range of complex charging conditions.

7.1.7 Pseudo-Spectral Optimization

Employing pseudo-spectral optimization requires solid theoretical underpinnings and a lot of battery data, which will present significant hurdles in real-world EV applications with expanding battery charging requirements. Various EV BMS technologies are discussed in the current paper, especially those related to battery modeling, state-of-the-battery (SOTB) estimation, and charging of batteries. Before being able to provide a hologram of the environment of the battery operation within EVs, battery modeling and state-of-the-battery estimation should be performed. An effective battery charging method can be developed to prevent battery damage, improve energy conversion efficiency, and prolong battery life after these crucial conditions have been identified. Ensuring modelling, estimating, and charging performance in real-world applications that deviate from test settings or in a worst-case scenario is difficult. Therefore, to solve this challenging problem, it is required to either build a confidence interval or look at the limitations of the given techniques and methodologies.

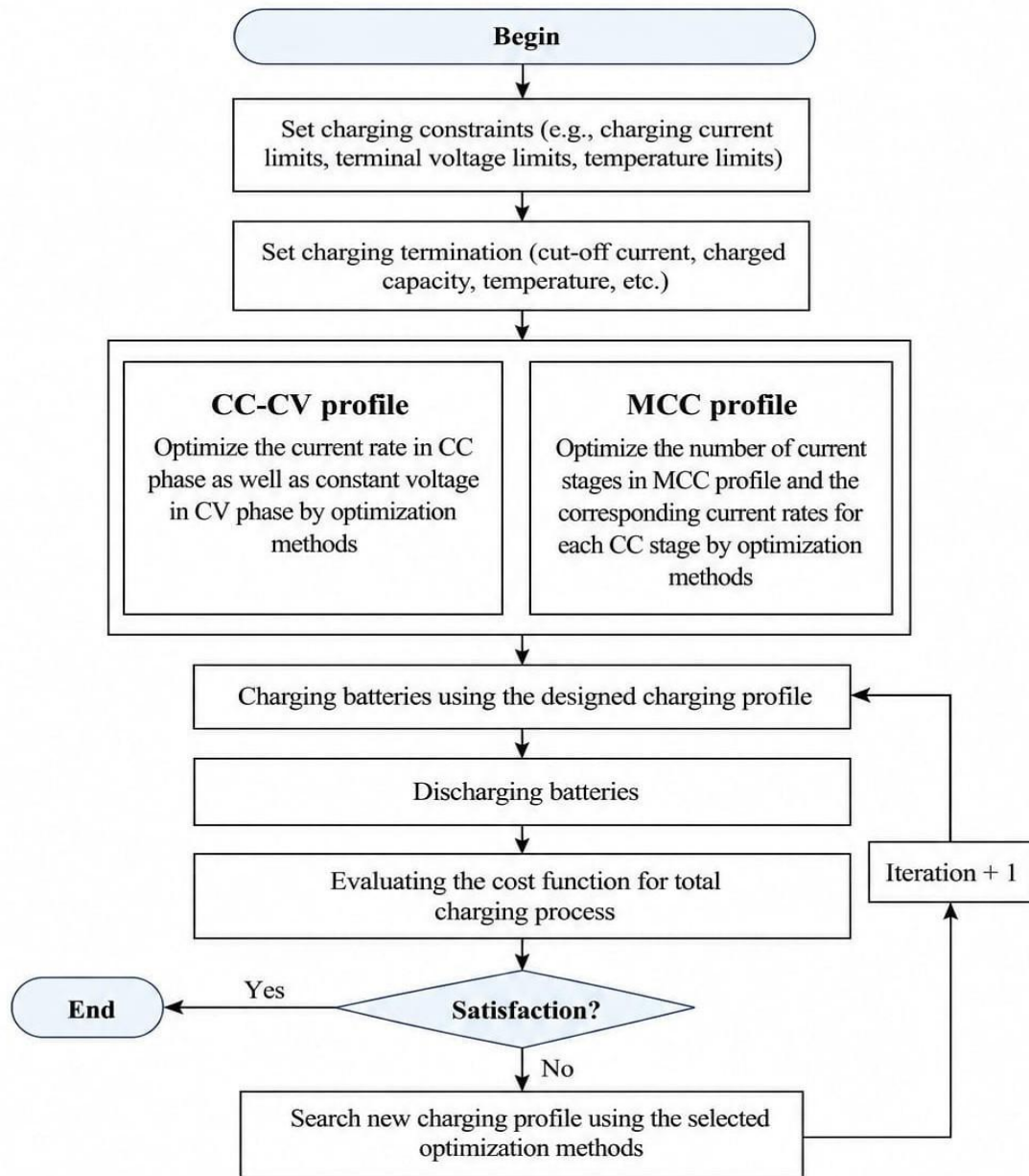

Figure.7.2 Overview of enhancements to the CC-CV/MCC charging strategy [39]

7.2 Summary

This chapter addresses the traditional approaches to battery charging, such as constant current (CC), constant voltage (CV), multiple constant currents (MCC), and constant current-voltage charging techniques. In the CC charging technique, there is a steady current provided to charge the batteries. Nevertheless, in case of high charging current, the temperature of the battery will

increase as well as its aging. On the other hand, in CV charging technique, there is a constant voltage applied to the battery, whereas charging current reduces gradually, preventing possible overvoltage of batteries.

CHAPTER 8

SIMULATION RESULTS AND DISCUSSION

8.1 MATLAB/SIMULINK Model Description

The power stage, battery dynamics, and CC-CV control strategy of the non-isolated half-bridge DC-DC converter are precisely modelled in MATLAB/Simulink using Simscape Electrical. Two actively switched MOSFETs organized in a half-bridge arrangement are used in the construction of the converter, together with a network of inductors and capacitors that smooth the voltage and shape the current at the battery side. The CC-CV control algorithm determines the duty cycle of a PWM generator that powers the switching circuitry. To capture nonlinear battery behaviour while charging, the battery is modelled using a comprehensive electrochemical block that offers real-time voltage, current, and State of Charge (SOC) values. To accomplish the dual charging technique, two PI controllers are used: a constant-voltage loop keeps the battery terminal voltage stable as it gets close to its upper threshold, while a constant-current loop controls inductor current during the bulk charging stage. When the battery's state of charge (SOC) surpasses 85%, the SOC-based mode selection logic automatically switches the converter from CC mode to CV mode. The converter starts the simulation in current-regulation mode, providing a regulated charging current until the battery voltage increases enough, at which point the system seamlessly switches to voltage regulation mode. Key parameters such as battery voltage, charging current, inductor current, converter switching states, and SOC progression are monitored through dedicated measurement blocks and visualized on the scope, enabling observation of the converter's dynamic response, stability, ripple characteristics, and charging profile. Overall, the simulation environment provides a complete platform to validate the behaviour of the proposed bidirectional converter, evaluate the performance of the CC-CV control algorithm, and study the interaction between converter dynamics and battery characteristics.

The MATLAB/Simulink simulation of the non-isolated half-bridge DC-DC converter integrates the power electronic stage, battery model, and CC-CV control strategy into a unified environment to accurately evaluate the converter's dynamic behaviour during EV charging. The power stage is

constructed using two complementary MOSFET switches configured in a half-bridge arrangement, which facilitates smooth bidirectional power transfer depending on the applied duty cycle. These switches are driven using a high-frequency PWM signal generated based on the selected control loop, allowing the converter to operate in both buck mode for charging and boost mode for reverse power flow. An inductor positioned between the converter output and the battery acts as the primary energy transfer component, enabling current regulation and reducing peak current stresses. The capacitors on both sides of the converter stabilize the voltage profiles, mitigate high-frequency ripple, and improve transient performance. The system is solved using a discrete powergui block with a time step of 1e-05 seconds, ensuring precise representation of the switching transitions and electrical waveforms. The battery subsystem employs a detailed nonlinear Simscape battery model that captures the effects of internal resistance, SOC-dependent open-circuit voltage, and charge acceptance dynamics.

These real-time outputs such as battery voltage, current, and state of charge (SOC) serve as input for the control system. The control logic of charging is achieved using different PI regulators to control both constant current (CC) and constant voltage (CV). During the constant current stage, the difference between battery current and its reference is monitored by the PI regulator. By varying the duty cycle, constant current can be achieved irrespective of changes in battery voltage or load. When SOC reaches 85% during the charging process, the control system automatically shifts control from CC mode to CV mode using a logic-based controller which includes AND, OR, and other logical gates. Under the constant voltage regulation, battery voltage is constantly monitored and compared against its final set point. Duty cycle will be varied by the PI regulator until the voltage remains constant, and the current will gradually decrease depending on battery properties. The simulation continuously records essential signals such as inductor current, battery current, battery voltage, SOC progression, and converter switching states. These signals are visualized using a multi-trace scope to enable detailed observation of the system's transient and steady-state performance. Throughout the simulated charging process, the model demonstrates proper regulation of current and voltage, stable mode transitions, controlled ripple behaviour, and realistic battery charging curves that reflect practical EV charging conditions. This detailed simulation environment provides a robust platform for analysing converter efficiency, validating

the CC–CV control strategy, and assessing the converter’s suitability for lightweight EV charging application

8.2 Simulation

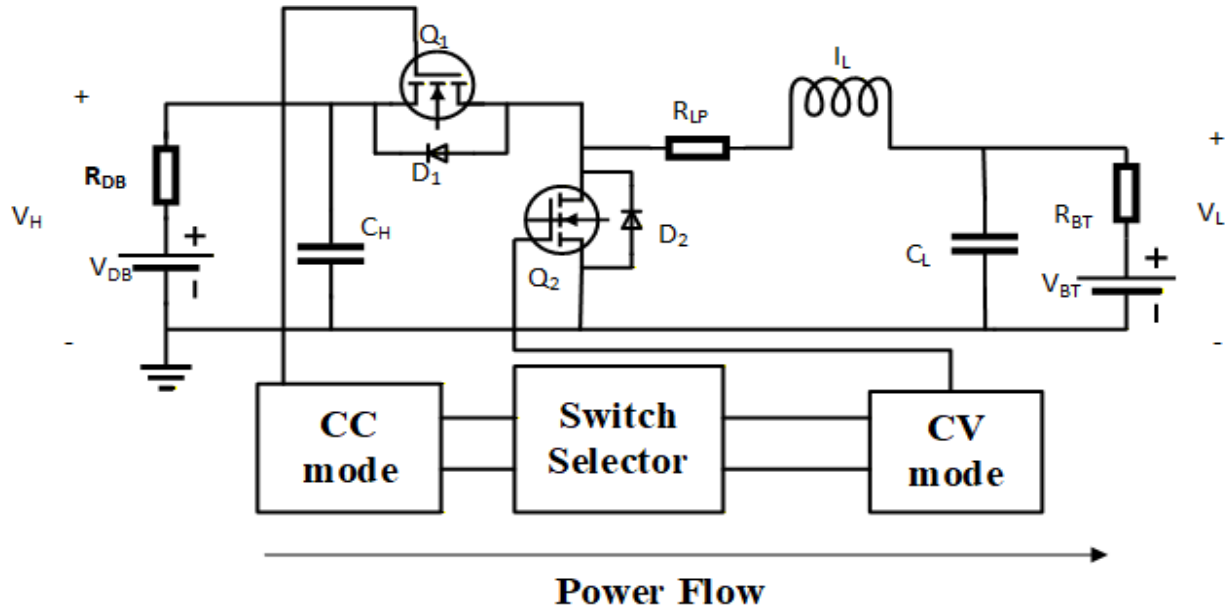

Fig. 8.1 Simulation Schematic of the proposed control algorithm of Converter

8.3 Circuit parameters

Input voltage	V_{DB}	200V
Output voltage	V_{BT}	48V
Output Current	I_L	21A
Load Resistance	R_{BT}	2.29Ω
Input current	I_{DB}	4.5A
Source resistance	R_{DB}	39.7Ω
Inductor	L	290μH
Output Capacitor	C_L	525μF

8.4 Proposed Control Schematic of the Converter

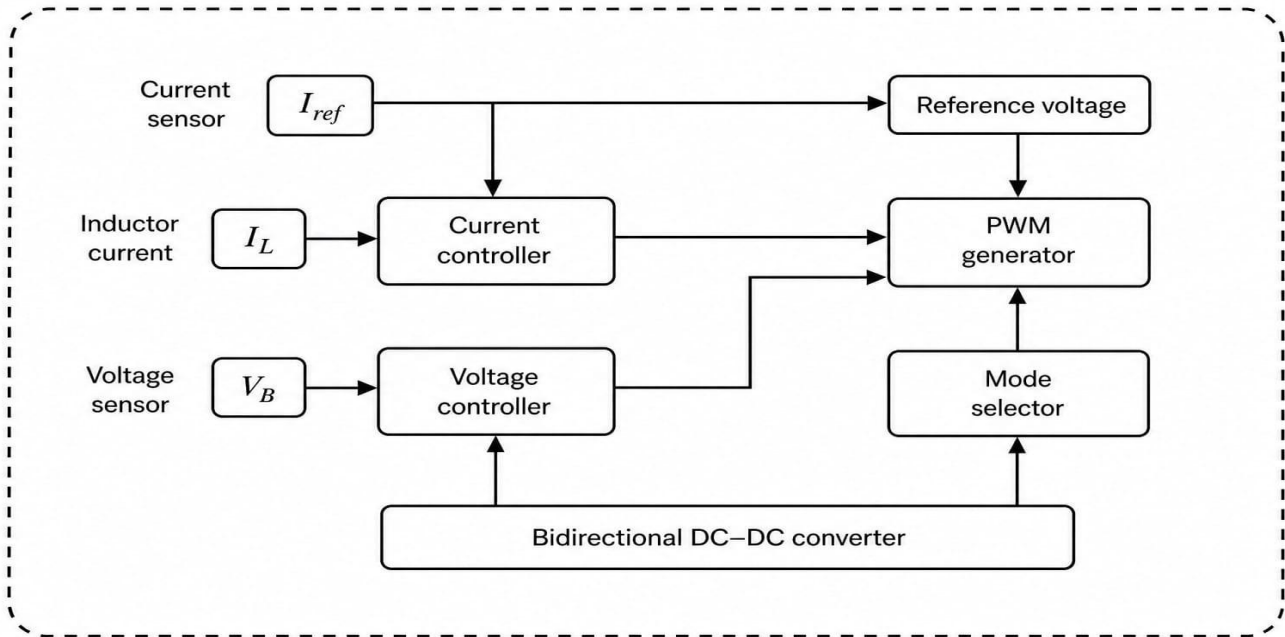

Fig.8.2 Block diagram of the proposed Converter Control System

Control scheme of the bidirectional DC–DC converter used for lightweight EV charging is presented in Figure 9.2. This control scheme aims to achieve proper regulation of the charging current as well as voltage of the battery. The main components of the control scheme include current and voltage sensors, current and voltage controller, pulse width modulator, mode selector, and the bidirectional DC–DC converter.

The existing sensor senses the reference current and inductor current. These two signals are fed into the current controller wherein there will be a comparison of actual and reference current. The current controller will produce the control signal to compensate for the errors during the charging process. In addition, the voltage sensor continually senses the battery voltage. This sensed voltage is then input to the voltage controller to control the output voltage of the DC-DC converter. This ensures that battery charging takes place under safe conditions without overcharging. The voltage controller assumes dominance during the constant voltage charging stage.

Both the current control output and voltage control output go to the PWM generator. Moreover, the reference voltage output and the mode selector are also connected to the PWM generator. With these inputs, the PWM generator generates pulses for driving the switching action of the converter

switches. The generated PWM pulses regulate the operation of the converter by controlling its duty cycle and thus regulating the energy transfer to the battery.

Selection of mode is done by mode selection switch based on charging needs. The converter can be operated under various modes like constant current (CC), constant voltage (CV), and bidirectional power transfer modes.

The two-way dc-dc converter functions as the primary stage for power conversion, and the power flow takes place in both directions. In charging mode, the power is sourced from the input source to the battery, but in discharging/regeneration mode, the power is sourced from the battery back to the input source.

In general, the presented control scheme enhances the efficiency, regulation of voltage, stability of current flow, and dynamic response of the EV charging system.

8.5 Comparative Analysis

Table.8.1 shows the comparison buck, boost and buck boost converter

Converter	Vo (V)	Io (A)	ΔV (V)	ΔI (A)	f (kHz)	Po (W)	Voltage Stress	Current Stress	Bidirectional Capability
Buck Converter	48	21	0.075	6.29	20	1008	Low	Moderate	No
Boost Converter	200	5.04	0.365	6.29	20	1008	High	High	No
Buck–Boost Converter	48	21	0.386	6.65	20	1008	Moderate–High	Moderate	Possible

Comparison between Buck, Boost, and Buck–Boost converters is made on the basis of output voltage, output current, ripple, switching frequency, output power, voltage stress, current stress, and bidirectionality in the context of charging electric vehicles (EVs) that require light-weight design. The Buck converter offers efficient voltage reduction along with low output voltage ripple

and moderate current stress and is, thus, an ideal converter for battery charging applications as it can provide reduced voltage from the higher input voltage. It cannot do voltage boost operation, though.

The Boost converter converts voltage from lower to higher value and hence is more ideal for cases where higher voltages are needed in comparison to the applied input voltage. Despite having high voltage gain, it suffers from high voltage and current stress owing to high duty cycle and switching nature.

The Buck-Boost converter allows voltage conversion in both directions (step-up and step-down), which increases the level of flexibility when compared to other topologies such as the Buck and Boost converters. Additionally, the Buck-Boost converter provides an option for bidirectional power flow, which is advantageous in applications related to lightweight electric vehicle charging and energy regeneration processes. Despite some disadvantages in the levels of ripple and stress, the flexibility and possibility of bidirectional operations make the Buck-Boost converter the best topology for the intended use.

Hence, among the discussed converter topologies, the Buck-Boost converter is considered to be the best choice for lightweight electric vehicle charging applications.

8.5.1 Reason for Simulating the Buck–Boost Converter

The Buck-Boost Converter has been considered for simulation purposes in this project owing to its ability to function for both boosting and bucking, making it appropriate for EV charging operations where minimal weight is desired. For instance, during EV charging applications, the voltages from the battery continue changing based on factors such as the battery's state of charge and operation requirements.

Whereas the Buck converter works solely on step down mode and the Boost converter works solely on step up mode, the Buck-Boost converter provides a more flexible option regarding voltage regulation. Thus, it works more effectively when the supply voltage is either below or above the battery voltage.

Another reason why the Buck–Boost converter has been chosen for use in this work is the fact that it is extendable for bi-directional power conversion, which is an essential feature in modern EVs

when using applications like regenerative braking, battery energy recovery, and V2G systems. Also, the Buck–Boost converter is capable of providing enhanced flexibility under variable loads and batteries while offering good ripple performance and stability.

8.6 Results

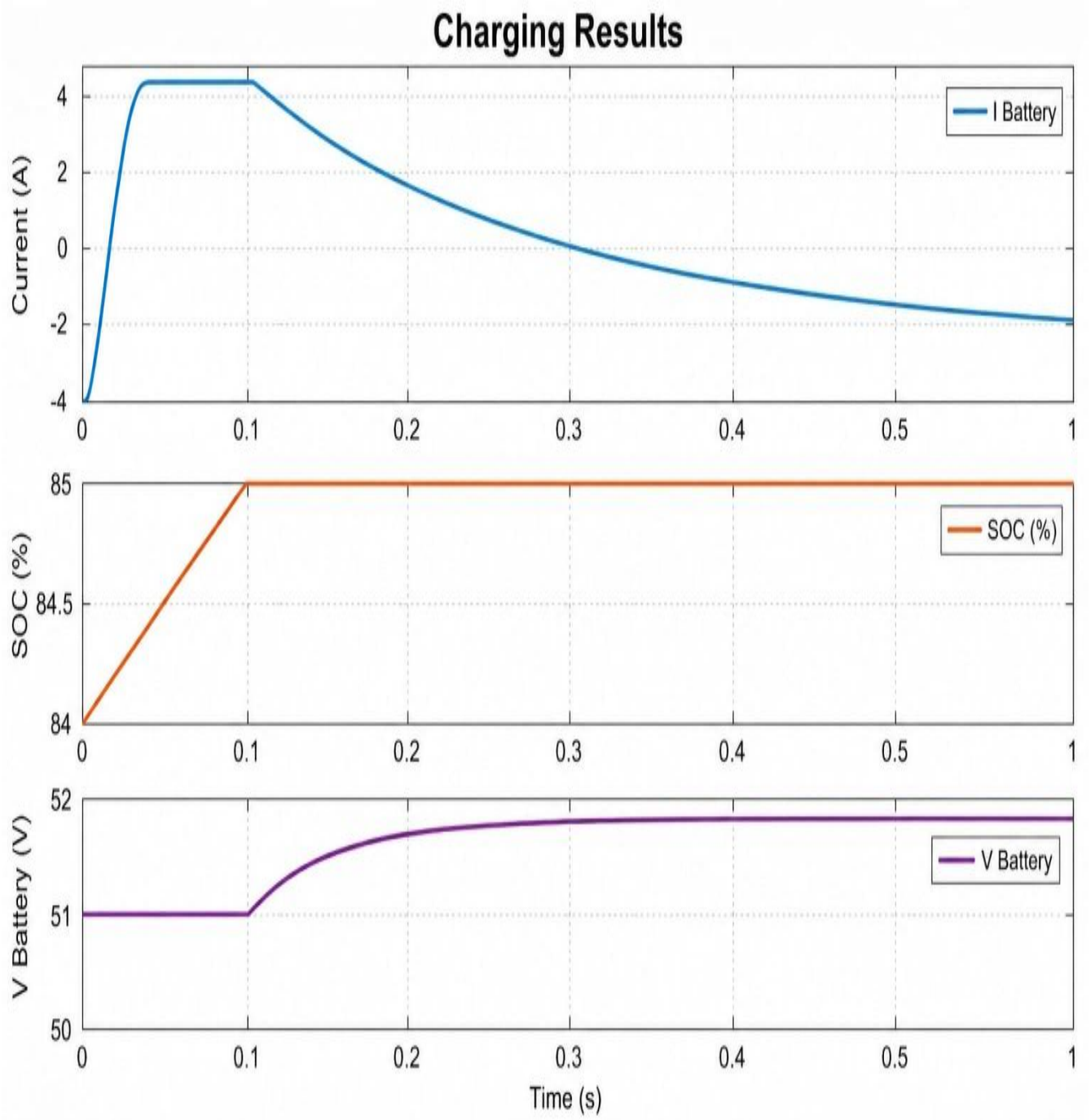

Fig.9.3. graph showing V Battery, I Battery

CHAPTER 9

CONCLUSION AND FUTURE SCOPE

9.1 Conclusion

The application of Constant Current Constant Voltage (CC-CV) charger to charge batteries using a non-isolated half-bridge DC-DC converter presents an efficient and dependable approach for lightweight Electric Vehicle (EV) charging applications.

In the constant current phase, the designed control system provides a regulated charging current to the battery, minimizing cell stress, and providing optimal conditions during the charging process. While in the constant voltage phase, the voltage regulation is performed to prevent any overcharging of the battery, ensuring long-term operation and extending battery life. The use of the CC-CV controller in conjunction with a bidirectional converter offers several advantages in terms of performance improvements through improved current and voltage tracking, minimized ripple effects, and faster dynamic response. Moreover, the half-bridge configuration offers some additional advantages in terms of component reduction, cost-effectiveness, and miniaturization.

9.2 Limitation

This current study deals with the modelling and control of a non-isolated half bridge DC-DC converter that finds application in light electric vehicle charging systems. Nevertheless, there are a few other avenues worth exploring through future studies. Some of the suggestions for future exploration include:

- 1.Implementation of Advanced Control Techniques
- 2.Hardware Prototype Development
- 3.Incorporation into Renewable Energy Sources
- 4.V2G Applications
- 5.Battery Management System Integration
- 6.Improvement in Efficiency and Reduction in Losses
- 7.Applications Involving High Power and Fast Charging

9.3 Summary

In this chapter, the discussion of the non-isolated half-bridge DC-DC converter for light-weight EV charging applications is summarized. The newly designed converter utilizing the CC-CV charging algorithm has provided the expected voltage stabilization, high efficiency, and efficient battery charging.

References

- [1] K. Saichand and V. John, "Simplified modeling of ultracapacitors for bidirectional DC–DC converter applications," in *Proc. IEEE Appl. Power Electron. Conf. Expo. (APEC)*, Mar. 2017.
- [2] G. Su and L. Tang, "A three-phase bidirectional DC–DC converter for automotive applications," in *Proc. IEEE Ind. Appl. Soc. Annu. Meeting (IAS)*, Edmonton, AB, Canada, Oct. 2008, pp. 1–7.
- [3] K. Venkatesan, "Current-mode controlled bidirectional flyback converter," in *Proc. IEEE Power Electron. Spec. Conf. (PESC)*, 1989, pp. 835–842.
- [4] M. Jain, P. K. Jain, and M. Daniele, "Analysis of a bidirectional DC–DC converter topology for low-power applications," in *Proc. IEEE Can. Conf. Electr. Comput. Eng. (CCECE)*, Jun. 1997, pp. 548–555.
- [5] C. G. Yoo, W. C. Lee, K. C. Lee, and I. Suh, "Current-mode PWM controller for a 42 V/14 V bidirectional DC/DC converter," in *Proc. IEEE Power Electron. Spec. Conf. (PESC)*, Jeju, South Korea, 2006, pp. 1747–1752.
- [6] M. A. Xavier and M. S. Trimboli, "Lithium-ion battery cell-level control using constrained model predictive control and equivalent circuit models," *J. Power Sources*, vol. 285, pp. 374–384, 2015.
- [7] F. Z. Peng, H. Li, G. J. Su, and J. S. Lawler, "A new ZVS bidirectional DC–DC converter for fuel cell and battery applications," *IEEE Trans. Power Electron.*, vol. 19, no. 1, pp. 54–65, Jan. 2004.
- [8] G. J. Su, F. Z. Peng, and D. J. Adams, "Experimental evaluation of a soft-switching DC–DC converter for fuel cell applications," in *Proc. Power Electron. Transp. Conf. (PET)*, 2002, pp. 39–44.
- [9] H. Li and F. Z. Peng, "Modeling of a new ZVS bidirectional DC–DC converter," *IEEE Trans. Aerosp. Electron. Syst.*, vol. 40, no. 1, pp. 272–283, Jan. 2004.
- [10] M. Jain, M. Daniele, and P. K. Jain, "A bidirectional DC–DC converter topology for low-power applications," *IEEE Trans. Power Electron.*, vol. 15, no. 4, pp. 595–606, Jul. 2000.
- [11] A. Bizeray, S. Zhao, S. Duncan, *et al.*, "Lithium-ion battery thermal-electrochemical model-based state estimation using orthogonal collocation and a modified extended Kalman filter," *J. Power Sources*, vol. 296, pp. 400–412, 2015.
- [12] C. Zhang, K. Li, and J. Deng, "Real-time estimation of battery internal temperature based on a simplified thermoelectric model," *J. Power Sources*, vol. 302, pp. 146–154, 2016.
- [13] A. C. C. Hua and B. Z. W. Syue, "Charge and discharge characteristics of lead-acid battery and LiFePO₄ battery," in *Proc. Int. Power Electron. Conf. (IPEC)*, Sapporo, Japan, 2010, pp. 1478–1483.
- [14] H. Perez, X. Hu, S. Dey, *et al.*, "Optimal charging of Li-ion batteries with coupled electro-thermal-aging dynamics," *IEEE Trans. Veh. Technol.*, vol. 66, no. 9, pp. 7761–7770, 2017.

- [15] N. Naik-Dhungel, “Portfolio standards and the promotion of combined heat and power,” *Combined Heat and Power Partnership Portfolio*, U.S. Environmental Protection Agency (EPA), Washington, DC, USA, 2013.
- [16] A. Khaligh and Z. Li, “Battery, ultracapacitor, fuel cell, and hybrid energy storage systems for electric, hybrid electric, fuel cell, and plug-in hybrid electric vehicles: State of the art,” *IEEE Trans. Veh. Technol.*, vol. 59, no. 6, pp. 2806–2814, Jul. 2010.
- [17] J. Intrator, E. Elkind, S. Weissman, and M. Sawchuk, *2020 Strategic Analysis of Energy Storage in California*, California Energy Commission, Sacramento, CA, USA, Rep. CEC-500-2011-047, 2011.
- [18] T. Logenthiran and D. Srinivasan, “Intelligent management of distributed storage elements in a smart grid,” in *Proc. IEEE 9th Int. Conf. Power Electron. Drive Syst. (PEDS)*, 2011, pp. 855–860.
- [19] D. A. Corrigan and A. Masias, “Batteries for electric and hybrid vehicles,” in *Linden’s Handbook of Batteries*, T. B. Reddy, Ed., 4th ed. New York, NY, USA: McGraw-Hill, 2011.
- [20] H. R. Eichi and M.-Y. Chow, “Modeling and analysis of battery hysteresis effects,” in *Proc. IEEE Energy Convers. Congr. Expo. (ECCE)*, 2012, pp. 4479–4486.
- [21] F. Baronti, G. Fantechi, R. Roncella, and R. Saletti, “Intelligent cell gauge for a hierarchical battery management system,” in *Proc. IEEE Transp. Electrification Conf. Expo. (ITEC)*, 2012, pp. 1–5.
- [22] M. M. Wenger, J. L. Grosch, M. Giegerich, M. P. M. Jank, M. Marz, and L. Frey, “Novel cost-efficient contactless distributed monitoring concept for smart battery cells,” in *Proc. IEEE Int. Symp. Ind. Electron. (ISIE)*, 2012, pp. 1342–1347.
- [23] M. Ecker, J. B. Gerschler, J. Vogel, S. Käbitz, F. Hust, P. Dechent, *et al.*, “Development of a lifetime prediction model for lithium-ion batteries based on extended accelerated aging test data,” *J. Power Sources*, vol. 215, pp. 248–257, Oct. 2012.
- [24] M. A. Roscher and D. U. Sauer, “Dynamic electric behavior and open-circuit-voltage modeling of LiFePO₄-based lithium-ion secondary batteries,” *J. Power Sources*, vol. 196, no. 1, pp. 331–336, Jan. 2011.
- [25] K. Liu, K. Li, and J. Deng, “A novel hybrid data-driven method for Li-ion battery internal temperature estimation,” in *Proc. UKACC 11th Int. Conf. Control (CONTROL)*, Belfast, U.K., 2016.
- [26] C. Lin, Q. Yu, R. Xiong, *et al.*, “A study on the impact of open-circuit voltage tests on state-of-charge estimation for lithium-ion batteries,” *Appl. Energy*, vol. 205, pp. 892–902, 2017.
- [27] T. R. Grandjean, A. McGordon, and P. A. Jennings, “Structural identifiability of equivalent circuit models for Li-ion batteries,” *Energies*, vol. 10, no. 1, p. 90, 2017.
- [28] S. X. Tang, L. Camacho-Solorio, Y. Wang, *et al.*, “State-of-charge estimation from a thermal-electrochemical model of lithium-ion batteries,” *Automatica*, vol. 83, pp. 206–219, 2017.
- [29] Z. Deng, L. Yang, Y. Cai, *et al.*, “Online available capacity prediction and state-of-charge estimation based on advanced data-driven algorithms for lithium iron phosphate battery,” *Energy*, vol. 112, pp. 469–480, 2016.

- [30] C. Sbarufatti, M. Corbetta, M. Giglio, *et al.*, “Adaptive prognosis of lithium-ion batteries based on the combination of particle filters and radial basis function neural networks,” *J. Power Sources*, vol. 344, pp. 128–140, 2017.
- [31] Y. Li, P. Chattopadhyay, S. Xiong, *et al.*, “Dynamic data-driven and model-based recursive analysis for estimation of battery state-of-charge,” *Appl. Energy*, vol. 184, pp. 266–275, 2016.
- [32] H. Dai, L. Zhu, J. Zhu, *et al.*, “Adaptive Kalman filtering-based internal temperature estimation with an equivalent electrical network thermal model for hard-cased batteries,” *J. Power Sources*, vol. 293, pp. 351–365, 2015.
- [33] L. H. Raijmakers, D. L. Danilov, J. P. van Lammeren, *et al.*, “Non-zero intercept frequency: An accurate method to determine the integral temperature of Li-ion batteries,” *IEEE Trans. Ind. Electron.*, vol. 63, no. 5, pp. 3168–3178, 2016.
- [34] S. Abada, G. Marlair, A. Lecocq, *et al.*, “Safety-focused modeling of lithium-ion batteries: A review,” *J. Power Sources*, vol. 306, pp. 178–192, 2016.
- [35] J. Bi, T. Zhang, H. Yu, *et al.*, “State-of-health estimation of lithium-ion battery packs in electric vehicles based on genetic resampling particle filter,” *Appl. Energy*, vol. 182, pp. 558–568, 2016.
- [36] D. Wang, F. Yang, K. L. Tsui, *et al.*, “Remaining useful life prediction of lithium-ion batteries based on spherical cubature particle filter,” *IEEE Trans. Instrum. Meas.*, vol. 65, no. 6, pp. 1282–1291, 2016.
- [37] M. Gholizadeh and F. R. Salmasi, “Estimation of state of charge, unknown nonlinearities, and state of health of a lithium-ion battery based on a comprehensive unobservable model,” *IEEE Trans. Ind. Electron.*, vol. 61, no. 3, pp. 1335–1344, 2014.
- [38] R. Srinivasan, B. G. Carkhuff, M. H. Butler, *et al.*, “Instantaneous measurement of the internal temperature in lithium-ion rechargeable cells,” *Electrochim. Acta*, vol. 56, no. 17, pp. 6198–6204, 2011.
- [39] K. Liu, Z. Li, and C. Zhang, “A brief review on key technologies in the battery management system of electric vehicles,” *Frontiers of Mechanical Engineering*, vol. 14, no. 1, pp. 47–64, 2019.
- [40] H. Beelen, L. Raijmakers, M. Donkers, *et al.*, “A comparison and accuracy analysis of impedance-based temperature estimation methods for Li-ion batteries,” *Appl. Energy*, vol. 175, pp. 128–140, 2016.
- [41] X. Wu, W. Shi, and J. Du, “Multi-objective optimal charging method for lithium-ion batteries,” *Energies*, vol. 10, no. 9, p. 1271, 2017.
- [42] T. Nguyen, H. Pham, and K. Lee, “Design and implementation of CC–CV charging controller for lithium-ion battery using bidirectional converters,” *IEEE Access*, vol. 12, pp. 23456–23470, 2024.
- [43] R. Verma and A. Sharma, “Performance analysis of bidirectional DC–DC converter with PID control for EV applications,” *Int. J. Electr. Power Energy Syst.*, vol. 155, 2024.
- [44] M. A. Xavier and M. S. Trimboli, “Lithium-ion battery cell-level control using constrained model predictive control and equivalent circuit models,” *J. Power Sources*, vol. 285, pp. 374–384, 2015.

- [45] H. Perez, X. Hu, S. Dey, *et al.*, “Optimal charging of Li-ion batteries with coupled electro-thermal-aging dynamics,” *IEEE Trans. Veh. Technol.*, vol. 66, no. 9, pp. 7761–7770, 2017.
- [46] X. Wu, W. Shi, and J. Du, “Multi-objective optimal charging method for lithium-ion batteries,” *Energies*, vol. 10, no. 9, p. 1271, 2017.
- [47] T. Nguyen, H. Pham, and K. Lee, “Design and implementation of CC–CV charging controller for lithium-ion battery using bidirectional converters,” *IEEE Access*, vol. 12, pp. 23456–23470, 2024.
- [48] R. Verma and A. Sharma, “Performance analysis of bidirectional DC–DC converter with PID control for EV applications,” *Int. J. Electr. Power Energy Syst.*, vol. 155, 2024.

KD_P1 O1

thesis main final 3-7

 Publications

Document Details

Submission ID

trn:oid:::27535:141370181

Submission Date

Jun 2, 2026, 12:55 PM GMT+5:30

Download Date

Jun 2, 2026, 1:20 PM GMT+5:30

File Name

thesis main final 3-7.pdf

File Size

1.8 MB

64 Pages

15,298 Words

85,052 Characters

Rg
10/6/26

6% Overall Similarity

The combined total of all matches, including overlapping sources, for each database.

Filtered from the Report

- Bibliography
- Small Matches (less than 14 words)

Match Groups

- 46 Not Cited or Quoted 6%**
Matches with neither in-text citation nor quotation marks
- 1 Missing Quotations 0%**
Matches that are still very similar to source material
- 0 Missing Citation 0%**
Matches that have quotation marks, but no in-text citation
- 0 Cited and Quoted 0%**
Matches with in-text citation present, but no quotation marks

Top Sources

- 4% Internet sources
- 5% Publications
- 0% Submitted works (Student Papers)

Integrity Flags

0 Integrity Flags for Review

No suspicious text manipulations found.

Our system's algorithms look deeply at a document for any inconsistencies that would set it apart from a normal submission. If we notice something strange, we flag it for you to review.

A Flag is not necessarily an indicator of a problem. However, we'd recommend you focus your attention there for further review.

Match Groups

- 211 Not Cited or Quoted 18%**
Matches with neither in-text citation nor quotation marks
- 1 Missing Quotations 0%**
Matches that are still very similar to source material
- 0 Missing Citation 0%**
Matches that have quotation marks, but no in-text citation
- 0 Cited and Quoted 0%**
Matches with in-text citation present, but no quotation marks

Top Sources

- 11% Internet sources
- 11% Publications
- 14% Submitted works (Student Papers)

Top Sources

The sources with the highest number of matches within the submission. Overlapping sources will not be displayed.

1	Internet	
academic.hep.com.cn		2%
2	Internet	
repository.lib.ncsu.edu		<1%
3	Publication	
Ranjan Pramanik, B.B. Pati. "Modelling and control of a non-isolated half-bridge b...		<1%
4	Publication	
Mohammad Aslam Alam, Ahmad Faiz Minai, Farhad Ilahi Bakhsh. "Isolated bidire...		<1%
5	Internet	
www.ijraset.com		<1%
6	Publication	
"Electric Vehicle Design", Wiley, 2024		<1%
7	Internet	
seeepedia.org		<1%
8	Internet	
tnsroindia.org.in		<1%
9	Student papers	
University of Leeds on 2023-05-04		<1%
10	Student papers	
Blinn College on 2025-12-04		<1%

11	Internet	www.mdpi.com	<1%
12	Internet	hdl.handle.net	<1%
13	Student papers	Engineering Institute of Technology on 2024-12-13	<1%
14	Student papers	Librarian NITT on 2026-05-25	<1%
15	Internet	www.researchgate.net	<1%
16	Publication	P. Justin Raj, V. Vasan Prabhu, K. Premkumar. "Fuzzy Logic-based Battery Manage...	<1%
17	Internet	en.sekorm.com	<1%
18	Internet	x-engineer.org	<1%
19	Student papers	Queen's University of Belfast on 2017-01-18	<1%
20	Internet	core.ac.uk	<1%
21	Student papers	Manipal Academy of Higher Education (MAHE) on 2024-11-18	<1%
22	Student papers	IIT Delhi on 2013-12-29	<1%
23	Internet	www.nature.com	<1%
24	Student papers	Indian Institute of Science Education and Research (IISER) Bhopal on 2021-07-14	<1%

25	Student papers	M S Ramaiah University of Applied Sciences on 2024-04-23	<1%
26	Student papers	University of Cape Town on 2021-02-23	<1%
27	Student papers	College of Engineering, Pune on 2019-07-06	<1%
28	Student papers	University of Nottingham on 2023-04-15	<1%
29	Student papers	University of Teesside on 2024-01-05	<1%
30	Student papers	Chester College of Higher Education on 2024-05-15	<1%
31	Student papers	University of Cape Town on 2015-10-14	<1%
32	Student papers	University of Colombo on 2023-01-29	<1%
33	Internet	dacemirror.sci-hub.ru	<1%
34	Internet	journalleit.org	<1%
35	Internet	dr.ddn.upes.ac.in:8080	<1%
36	Internet	www.jstage.jst.go.jp	<1%
37	Publication	Md. Rabiul Islam. "Emerging Power Converters for Renewable Energy and Electric..."	<1%
38	Internet	pubs.rsc.org	<1%

39	Internet	www.coursehero.com	<1%
40	Student papers	Higher Education Commission Pakistan on 2021-08-11	<1%
41	Publication	Mohamed, Mohamed. "Optimised DC Microgrid for Future Aircraft Platforms", Un...	<1%
42	Publication	Shameem Hasan, Abdullah Al-Muiz Upam, Mejbaul Haque, Prangon Chowdhury, ...	<1%
43	Student papers	The University of Manchester on 2009-09-07	<1%
44	Student papers	University of Salford on 2014-01-24	<1%
45	Student papers	University of Western Sydney on 2025-02-01	<1%
46	Internet	evertiq.com	<1%
47	Internet	profdoc.um.ac.ir	<1%
48	Student papers	Higher Education Commission Pakistan on 2016-06-23	<1%
49	Publication	Parmar, Sheetal Shantilal. "Design and Implementation of an Improved Battery C...	<1%
50	Student papers	Texas A&M University, College Station on 2018-05-01	<1%
51	Internet	www.ersaelectronics.com	<1%
52	Student papers	Anna University on 2026-01-08	<1%

53	Student papers	Frederick University on 2026-04-20	<1%
54	Publication	Noshin Omar, Dhammika Widanage, Mohamed Abdel Monem, Yousef Firouz et al...	<1%
55	Student papers	Tameside College on 2026-03-17	<1%
56	Student papers	Universitas Indonesia on 2025-10-08	<1%
57	Student papers	Universiti Sains Malaysia on 2013-03-29	<1%
58	Student papers	Universiti Tenaga Nasional on 2016-07-27	<1%
59	Student papers	University of Sunderland on 2026-05-16	<1%
60	Internet	creativeidee.github.io	<1%
61	Internet	journals.pen2print.org	<1%
62	Internet	www.rroj.com	<1%
63	Student papers	Ajman University of Science and Technology on 2025-09-18	<1%
64	Publication	Chen, Siru, Ming Xue, Yanqiang Li, Ying Pan, Liangkui Zhu, and Shilun Qiu. "Ratio..."	<1%
65	Student papers	Imperial College of Science, Technology and Medicine on 2009-03-13	<1%
66	Student papers	Polytechnic of Turin on 2024-09-06	<1%

67	Student papers	Queen Mary and Westfield College on 2023-03-20	<1%
68	Student papers	Universiti Tenaga Nasional on 2016-02-19	<1%
69	Student papers	University Tun Hussein Onn Malaysia on 2019-05-13	<1%
70	Internet	circuitdigest.com	<1%
71	Internet	uia.brage.unit.no	<1%
72	Student papers	(school name not available) on 2007-02-27	<1%
73	Student papers	Aalto Yliopisto on 2023-12-20	<1%
74	Student papers	College of Engineering, Pune on 2020-09-17	<1%
75	Student papers	Griffth University on 2015-10-28	<1%
76	Student papers	Harcourt Butler Technical University on 2026-05-18	<1%
77	Student papers	Librarian NITT on 2026-05-25	<1%
78	Publication	Lin Liu. "Automotive, Mechanical and Electrical Engineering", CRC Press, 2017	<1%
79	Student papers	Panimalar Engineering College on 2026-03-30	<1%
80	Student papers	The University of Manchester on 2019-05-13	<1%

81	Student papers	Universiti Tenaga Nasional on 2011-12-02	<1%
82	Student papers	Universiti Tenaga Nasional on 2012-02-21	<1%
83	Student papers	University College London on 2021-09-02	<1%
84	Student papers	University of Edinburgh on 2022-08-15	<1%
85	Student papers	University of Hertfordshire on 2026-04-27	<1%
86	Student papers	University of Malaya on 2011-04-19	<1%
87	Student papers	University of Newcastle upon Tyne on 2013-08-29	<1%
88	Student papers	University of Nottingham on 2010-04-12	<1%
89	Student papers	University of Nottingham on 2019-12-30	<1%
90	Student papers	University of Sydney on 2014-10-31	<1%
91	Student papers	University of Warwick on 2020-09-15	<1%
92	Student papers	Victoria University on 2017-12-30	<1%
93	Internet	diginole.lib.fsu.edu	<1%
94	Internet	docplayer.net	<1%

95	Internet	es.slideshare.net	<1%
96	Student papers	iGroup on 2014-07-17	<1%
97	Internet	libres.uncg.edu	<1%
98	Internet	s-space.snu.ac.kr	<1%
99	Internet	tel.archives-ouvertes.fr	<1%
100	Internet	www.docme.ru	<1%
101	Internet	www.grin.com	<1%
102	Student papers	APJ Abdul Kalam Technological University, Thiruvananthapuram on 2025-04-21	<1%
103	Publication	Aliyu M. Aliyu, Joseph Xavier Francisco Ribeiro. "Sustainable Technologies for the ...	<1%
104	Publication	Ambuj Sharma, Soumya Shubhra Nag, Gurumoorthy Bhuvaneswari, Mummadi Ve...	<1%
105	Student papers	College of Engineering, Pune on 2022-08-02	<1%
106	Student papers	Dr. Ambedkar Institute of Technology on 2016-05-25	<1%
107	Student papers	Heriot-Watt University on 2013-08-25	<1%
108	Student papers	Indian Institute of Information Technology, Design and Manufacturing - Kanchee...	<1%

109	Student papers	Institute of International Studies on 2023-12-12	<1%
110	Publication	Iqbal Husain. "Electric and Hybrid Vehicles - Design Fundamentals", CRC Press, 20...	<1%
111	Publication	Jaya Sai Praneeth Ammanamanchi Venkata, Sheldon S. Williamson. "Analysis and ...	<1%
112	Student papers	Queen Mary and Westfield College on 2020-05-10	<1%
113	Student papers	RMIT University on 2026-03-29	<1%
114	Publication	Sharma, Angshuman. "Introduction of a Variable Inductance Transformer for the ...	<1%
115	Student papers	Texas A&M University, College Station on 2014-02-24	<1%
116	Student papers	Texas A&M University, College Station on 2020-10-12	<1%
117	Student papers	The University of Manchester on 2018-09-01	<1%
118	Student papers	University College London on 2018-09-03	<1%
119	Student papers	University of Huddersfield on 2023-09-09	<1%
120	Student papers	University of Michigan, Dearborn on 2010-12-04	<1%
121	Student papers	University of Pretoria on 2012-04-19	<1%
122	Student papers	University of Sheffield on 2021-09-04	<1%

123	Student papers	University of Southampton on 2018-09-21	<1%
124	Student papers	University of Warwick on 2019-08-20	<1%
125	Student papers	University of the West Indies on 2014-04-22	<1%
126	Student papers	Visvesvaraya National Institute of Technology on 2021-06-16	<1%
127	Student papers	Visvesvaraya Technological University on 2014-10-29	<1%
128	Internet	academica-e.unavarra.es	<1%
129	Internet	asmedigitalcollection.asme.org	<1%
130	Internet	digibuo.uniovi.es	<1%
131	Internet	theses.whiterose.ac.uk	<1%
132	Internet	journal.hep.com.cn	<1%
133	Internet	serialsjournals.com	<1%
134	Internet	www.ieee-jas.net	<1%
135	Internet	www.ijprems.com	<1%
136	Internet	www.wacong.org	<1%

137

Internet

www.xecor.com

<1%

KD_P1 O1

thesis main final 3-7

 Publications

Document Details

Submission ID

trn:oid:::27535:141370181

Submission Date

Jun 2, 2026, 12:55 PM GMT+5:30

Download Date

Jun 2, 2026, 1:08 PM GMT+5:30

File Name

thesis main final 3-7.pdf

File Size

1.8 MB

64 Pages

15,298 Words

85,052 Characters

Rohanfilai

02.06.26

*Ayamul
betmen*

*% detected as AI

AI detection includes the possibility of false positives. Although some text in this submission is likely AI generated, scores below the 20% threshold are not surfaced because they have a higher likelihood of false positives.

Caution: Review required.

It is essential to understand the limitations of AI detection before making decisions about a student's work. We encourage you to learn more about Turnitin's AI detection capabilities before using the tool.

Disclaimer

Our AI writing assessment is designed to help educators identify text that might be prepared by a generative AI tool. Our AI writing assessment may not always be accurate (i.e., our AI models may produce either false positive results or false negative results), so it should not be used as the sole basis for adverse actions against a student. It takes further scrutiny and human judgment in conjunction with an organization's application of its specific academic policies to determine whether any academic misconduct has occurred.