

DESIGN AND DEVELOPMENT OF COST-EFFECTIVE LED BASED SOLAR SIMULATOR

**A Dissertation submitted
in Partial Fulfillment of the Requirement for the
Degree of**

**MASTER OF SCIENCE
in
Physics**

**by
Abhay Pratap
Roll No. 24/MSCPHY/01**

**Under the Supervision of
Dr. Sarita Baghel
Assistant Professor
Department of Applied Physics
Delhi Technological University**



**Department of Applied Physics
DELHI TECHNOLOGICAL UNIVERSITY
(Formerly Delhi College of Engineering)
Shahbad Daultpur, Main Bawana Road, Delhi-42**

MAY, 2026



DELHI TECHNOLOGICAL UNIVERSITY
(Formerly Delhi College of Engineering)
Shahbad Daulatpur, Main Bawana Road, Delhi-42

CANDIDATE DECLARATION

I, Abhay Pratap, Roll No. 24/MSCPHY/01, hereby declare that the work which is being presented in the Dissertation Report entitled '*Design and Development of Cost-effective LED based Solar Simulator*', in partial fulfillment of the requirements for the award of the Degree of Master of Science, submitted in the Department of Applied Physics, Delhi Technological University is an authentic record of my own work carried out during the period from August 2025 to May 2026 under the supervision of Dr. Sarita Baghel.

The matter presented in the Dissertation Report has not been submitted by me for the award of any other degree of this or any other Institute.

Candidate Signature

Date:

This is to certify that the student has incorporated all the correction suggested by the examiner in the Dissertation Report and the statement made by the candidate is correct to the best of our knowledge.

Signature of Supervisor

Signature of Examiner

Date:



DELHI TECHNOLOGICAL UNIVERSITY
(Formerly Delhi College of Engineering)
Shahbad Daulatpur, Main Bawana Road, Delhi-42

CERTIFICATE BY THE SUPERVISOR

Certified that Abhay Pratap, Roll No. 24/MSCPHY/01, has carried out their research work presented in this Dissertation Report entitled '*Design and Development of Cost-effective LED based Solar Simulator*', for the award of Master of Science from the Department of Applied Physics, Delhi Technological University, Delhi, under my supervision. The Dissertation Report embodies results of original work, and studies are carried out by the student himself and the contents of the Dissertation Report do not form the basis for the award of any other degree to the candidate or to anybody else from this or any other University/Institute.

Signature

Dr. Sarita Baghel
Assistant Professor
Department of Applied Physics

Date:

ACKNOWLEDGEMENT

I would like to express my deepest gratitude to my supervisor, Dr. Sarita Baghel Ma'am. Her deep concern for the environment and sustainability is truly inspiring to me. I am grateful for her dedication and faithfulness to her work. She always motivated me to think out of the box and guided me whenever I faced challenges. Her unwavering support was the main reason I could finish this project successfully.

I am also very thankful to Miss Vanshika, Ph.D. scholar, for her constant mentorship. She guided me step-by-step, from understanding how to do a literature review to the process of writing a research paper. Her patience and advice helped me learn a lot during this semester.

I thank the Department of Applied Physics at Delhi Technological University for providing the necessary resources and laboratory facilities to conduct this work. I also appreciate the faculty and non-teaching staff for their assistance.

I would like to thank my friends and classmates for their support. A special mention goes to Kislay and Jitender for their hands-on help with the soldering work.

Finally, I express my deepest gratitude to my parents. Their unconditional love, patience, and silent sacrifices have been my greatest strength. They have always believed in me, even during the toughest times, and no achievement of mine would have been possible without their blessings.

Abhay Pratap

Design and Development of Cost-effective LED based Solar Simulator.

Abhay Pratap

ABSTRACT

The critical need for national energy security combined with the growing energy demands of the modern world require a transition from fossil fuels to clean and indigenous fuel alternatives. This makes solar energy and photovoltaic technology a primary focus for the scientific community. To enhance solar cell efficiency, photovoltaic devices must be tested and characterized under standard atmospheric conditions using a device known as a solar simulator. However traditional solar simulators rely on bulky and expensive light sources with short lifespans. This makes them out of reach for many small scale research facilities.

This dissertation report outlines the design and assembly of a low-cost, five channel Light Emitting Diode (LED) based solar simulator and its feasibility to reach the Class AAA standard. The optical unit consists of five colour LEDs which are soldered in a general purpose Printed Circuit Board (PCB), paired with a mirror frustum assembly to collimate and mix the beam. The use of an Arduino microcontroller driving a low-side N-channel MOSFET switching circuit and Pulse Width Modulation (PWM) provides precise linear control on the intensity of light without any mechanical filter. The prototype is then validated using a solar power meter. Its intensity heatmap is generated and it achieves a Class B rating in the spatial non-uniformity parameter. The overall build cost is well below commercial solar simulators and it acts as a foundational first step in making an economical solar simulator. The report also lists out various improvements that could be incorporated to the simulator to truly achieve a Class AAA rating.

TABLE OF CONTENTS

Title	Page No.
Declaration	i
Certificate	ii
Acknowledgement	iii
Abstract	iv
List of Tables	vii
List of Figures	viii
List of Symbols and Abbreviations	ix
CHAPTER 1: INTRODUCTION	1
CHAPTER 2: LITERATURE REVIEW	4
2.1 Solar Spectrum	4
2.1.1 Air Mass Coefficient	4
2.2 Solar Simulator	6
2.3 Solar Simulator Standard	7
2.4 Light sources for Solar Simulator	10
2.5 LED based Solar Simulator	10
CHAPTER 3: DEVICE ARCHITECTURE AND ASSEMBLY	13
3.1 Overview of Proposed System	13
3.2 The Optical Unit	14
3.2.1 Selection of Light Source (LEDs)	14
3.2.2 Assembly of the LEDs	17
3.2.3 Mirrors and Diffuser	18
3.3 Electrical Unit	19
3.4 Control Unit	19
3.4.1 PWM based LED Intensity Control	21
3.4.2 Arduino UNO setup	22
3.5 Final Device Assembly	24
3.5.1 Circuit Schematics	24

3.5.2 Physical Prototype	25
CHAPTER 4: EXPERIMENTAL VERIFICATION	26
4.1 Spatial Non-Uniformity	31
CHAPTER 5: FUTURE SCOPE	33
CHAPTER 6: CONCLUSION	35
REFERENCES	36
APPENDIX A: Arduino Code	39
APPENDIX B: Plagiarism Report	41

LIST OF TABLES

2.1	Specification defined by different standards for Class A+, A, B and C solar simulator. Data from [6], [7], [8].	8
2.2	Target irradiance contribution per bandwidth as defined by IEC 60904-9 (2020). Data from [6].	9
2.3	Target irradiance contribution per bandwidth as defined by JIS C 8904-9 and ASTM E927-10. Data from [7], [8].	9
3.1	Specification of different LEDs [14].	16
4.1	PWM signal of varying duty cycle and its corresponding intensity . .	28
4.2	Distance of test plane and intensity values	29
4.3	LEDs of different colour and their peak intensity	30

LIST OF FIGURES

2.1	The global reference spectrum (AM 1.5G) distribution (IEC 60904-9) [3]	4
2.2	Visual representation of AM 1.5 spectral condition [3]	5
2.3	Spectrum reference AM 1.5 Global vs Direct [5]	6
2.4	Wavelength range of light sources [3].	10
2.5	Solar simulator spectrum produced by López-Fraguas <i>et al.</i> [10]	11
2.6	Sun <i>et al.</i> [11] setup and results.	11
2.7	Solar simulator spectrum of Ossila Solar Simulator [12].	12
2.8	Solar simulator spectrum of Newport's VeraSol-2 [13].	12
3.1	Schematics of the prototype device.	13
3.2	Emission spectrum of a phosphor based white LED [14].	15
3.3	Typical diode forward voltage versus bandgap energy for LEDs [14].	16
3.4	LED grid assembly	17
3.5	LED assembly of each colour	17
3.6	Hexagonal Micro Lens Array Diffuser	18
3.7	Circuit diagram of a single LED driver circuit using MOSFET. Made with EasyEDA [16]	20
3.8	Plots showing linear Relationship between PWM duty cycle and illuminance [19].	22
3.9	ATmega328P Pin details with Arduino functions [21].	23
3.10	Arduino UNO Development board [22].	23
3.11	Arduino IDE (Integrated Development Environment) interface [22].	24
3.12	Schematic of a 5 channel LED driver circuit using MOSFET and Arduino.	24
3.13	Physical Prototype	25
4.1	Device test setup in horizontal position.	26
4.2	Tenmars TM-207 Solar Power Meter	27
4.3	Intensity vs PWM signal duty cycle	28
4.4	Intensity vs distance plot	29
4.5	Colour vs intensity plot.	30
4.6	Spatial Irradiance Heatmap	32
B.1	Turnitin Similarity Report.	42
B.2	Turnitin AI Report.	44

LIST OF SYMBOLS

Symbol	Description
I_{SC}	Short Circuit Current
V_{OC}	Open Circuit Voltage
V_S	Source Voltage
V_f	Forward Voltage
I_{led}	LED Forward Current
V_{GS}	MOSFET Gate Source Voltage
I_D	MOSFET Drain Current

LIST OF ABBREVIATION

Abbreviation	Full Form
PV	Photovoltaic
STC	Standard Test Conditions
AM	Air Mass
DUT	Device Under Test
LED	Light Emitting Diode
MLA	Micro Lens Array
PWM	Pulse Width Modulation
MOSFET	Metal-Oxide-Semiconductor Field-Effect Transistor
PCB	Printed Circuit Board

Chapter 1

INTRODUCTION

The energy demands of the modern world are growing at an unprecedented rate. With the recent boom in Artificial Intelligence companies and an increase in the number of large energy intensive data centers, global energy consumption is expected to grow even more. However, meeting these demands with the limited fossil fuels is not sustainable in the long term and the transition to a better and indigenous energy source is the need of the hour. Solar energy comes as the promising contender for this transition. This is supported by its wide availability in the tropical zone, robust technology and self-reliance in terms of energy production. Hence more research in enhancing solar cell efficiency, increasing energy output and characterization is a priority for the scientific community.

Photovoltaic Device Characterization

At the center of this all are Solar Photovoltaic cells that are solid state nonmechanical devices and convert solar radiation directly into electrical energy. They are durable and have simple design, requiring little maintenance. The development of any photovoltaic cell involves 3 distinct stages.

1. The **Design and Simulation** part where a model of proposed cell is designed in simulation software programs and different characteristics are measured. It includes tweaking and tuning different parameters and finding the optimal value for different parameters.
2. In the second step the actual physical device is **fabricated** using various chemical and physical processes.
3. In the third and last step the **characterization** and testing of the device is done to determine key performance metrics.

The parameters of any photovoltaic device like current-voltage curve, short circuit current (I_{SC}), open circuit voltage (V_{OC}) and maximum power (P_{MAX}) must be analyzed under actual atmospheric conditions. The spectral and total irradiance which have to be used for the characterization and calibration of a solar cell are defined by the IEC (International Electrotechnical Commission) in the IEC 60904-3 standard as

Standard Test Condition. Hence to evaluate the performance of a particular photovoltaic technology, it is rated under the Standard Test Condition (STC). This is defined as irradiance of 1000 W/m^2 , the spectrum taken as AM1.5 and a device temperature is kept at 25°C [1]. While the I-V measurement can be done outside under the natural sunlight during the day, it is not preferred due to irregular solar radiation which depends on the atmospheric conditions, time of day and the geographical location. Therefore it is preferred to do the testing in a controlled laboratory environment by using a device known as a Solar Simulator.

Problem Statement

Traditionally solar simulators were made using conventional sources like Xenon lamp or Halogen tungsten lamp. They matched the solar spectrum to an extent but had many disadvantages. They were bulky, expensive, generated too much heat and had a very short lifetime. Furthermore, due to their cost, they remained out of reach for many small scale research facilities and universities. Therefore there was a need for a Low cost, compact and safe alternative. LED based solar simulators were introduced as a solution. LEDs have many advantages as compared to conventional light sources. They are low cost, have a long life, fast switching speed and narrow spectral bandwidth. These properties allow us to fine tune the output intensity of an LED and by combining LEDs of different wavelengths, we can mimic the entire solar spectrum.

Objective

The objective of this project was to design and assemble a cost-effective LED based solar simulator and to test the feasibility of reaching the Class AAA standard.

Chapter Outline

Chapter 2 presents a review of relevant literature, defining the basic terminology related to a solar spectrum. It lists the standards used to classify a solar simulator. It also briefs on the different light sources used for traditional simulators. The chapter ends with an overview of LED-based solar simulators made by research groups and different commercially available models.

Chapter 3 details the Device Architecture and Assembly. It discusses the different units of the solar simulator namely the optical, electrical and control units. It explains the assembly of LEDs soldered in a zero PCB and the mirror assembly for collimating the light, the electrical unit and the design of Arduino based intensity control system.

Chapter 4 outlines the experimental characterization that was done using a solar power meter. Out of the three parameters used to characterize a solar simulator, only the spatial non-uniformity part could be tested due to constraints in availability of a spectrometer. Others, like the intensity control, its variation with distance and output power of each colour LED type were also recorded.

Chapter 5 outlines the future scope of this project and lists various additions and features that could be added to further develop the simulator. The last chapter 6 concludes the report.

Chapter 2

LITERATURE REVIEW

In this section, we'll have an overview of the Solar Spectrum, Solar simulators, different light sources used in solar simulators and finally LED based solar simulators.

2.1 Solar Spectrum

The Sun essentially acts as a perfect black body radiator with a surface temperature of 5,778 K. Therefore in outer space, solar spectrum appears as a smooth continuous curve known as Air Mass 0 (AM0) spectrum. However, when this radiation enters the Earth's atmosphere, it interacts with the atmospheric molecules which modifies the spectrum significantly by processes such as absorption, dispersion and scattering. These interactions cause certain dips in the smooth spectrum and hence we get the jagged, terrestrial profile known as AM 1.5 Global spectrum [2].

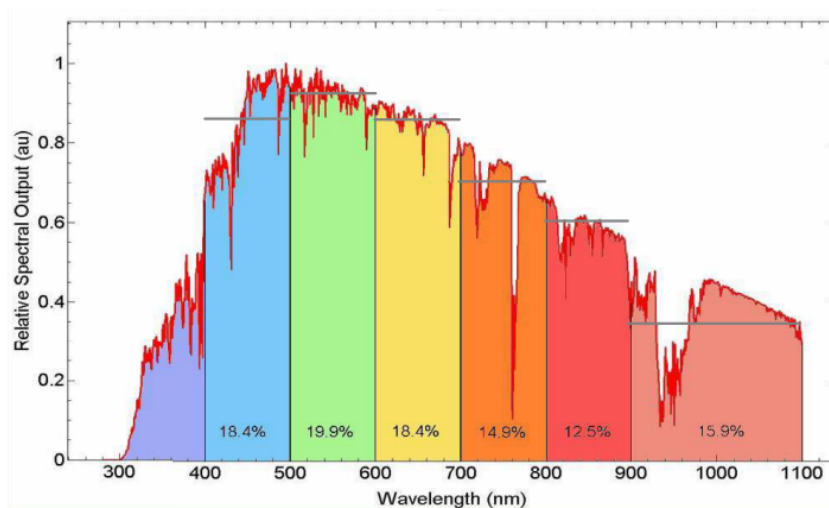

Figure 2.1: The global reference spectrum (AM 1.5G) distribution (IEC 60904-9) [3]

2.1.1 Air Mass Coefficient

It is a dimensionless quantity used to characterize the effect of Earth's atmosphere on the spectral distribution and intensity of sunlight reaching the surface.

Mathematically it is shown as

$$AM = \frac{L}{L_0} = \frac{1}{\cos(\theta)} = \sec(\theta) \quad (2.1)$$

where L_0 is the shortest path possible, when sun is directly overhead at the zenith and L is the path taken by the light at an angle θ relative to the vertical, i.e, the zenith angle.

There are three specific Air Mass values which are used as standard:

- AM0 - Extraterrestrial. This is the spectrum of Sun outside the Earth's atmosphere in space. This standard is used for satellite application.
- AM1 D - Direct overhead. This is the spectrum at the zero altitude when sun is as its zenith. Here $\theta = 0$.
- AM1.5G - Global Standard. This is the spectrum when the sun is at a zenith angle of $\theta = 48.19^\circ$

Other standards include AM 1G, AM 1.5D, AM 2D and AM 2G.

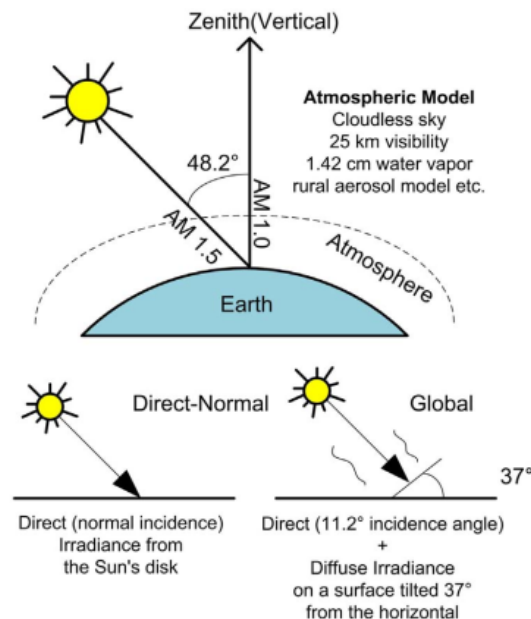

Figure 2.2: Visual representation of AM 1.5 spectral condition [3]

AM1.5G

This is the global standard defined by ASTM G173-9 [4]. All commercial solar cells are rated against this spectrum. In this standard the integrated intensity (power) is normalized to exactly 1000W/m^2 and is called 1 Sun.

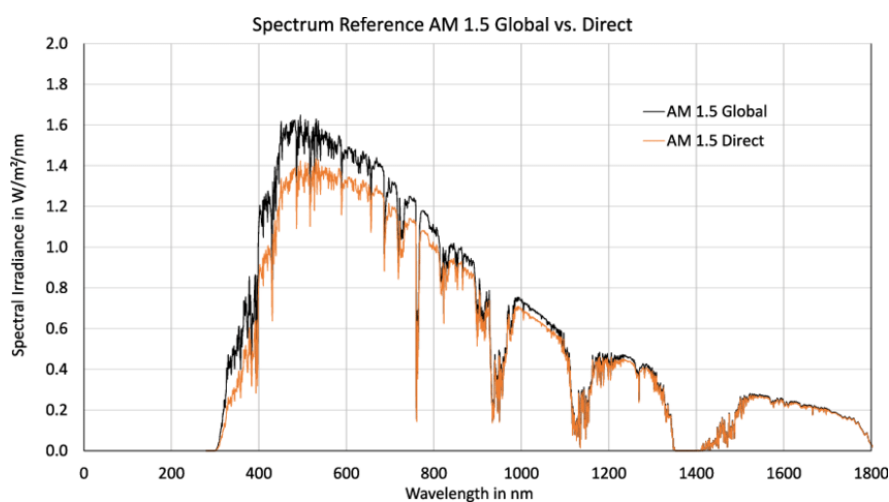

Figure 2.3: Spectrum reference AM 1.5 Global vs Direct [5]

2.2 Solar Simulator

As stated in the introduction part, there are two ways to test any solar cell. First being in the outdoor environment under actual solar radiation and second being inside a laboratory using a solar simulator. Testing under outdoor environment is not usually preferred due to factors like intensity and the spectral distribution of solar radiation, time and day of the year, the weather or climate of the outdoor, atmospheric conditions, geographical location and various longitudinal and altitude variations. To mitigate these problems, it is preferred to perform testing under a closed controlled environment. The solar simulator provide such solution. They are devices which try to mimic the sun, basically by generating the same spectral and optical composition as that of sunlight. Since the solar simulators are artificially controlled by humans, they provide a simple, reliable and reproducible method for testing photovoltaic technologies. Any solar simulator consists of three core parts:

- The optical part which consists of light generating source, the optical filter or manipulator to change the light properties fulfilling the standard requirement
- The control part to operate the simulator
- The power source to run the whole device.

Early solar simulators relied on Carbon arc and quartz-tungsten filament. Later, gas discharge technologies like metal halide, mercury-xenon and both continuous and pulsed xenon arc variants became prominent. Nowadays solid state lighting like LED and super continuum laser light sources, are being used for high precise spectral matching [3]. They have been discussed in detail in section 2.4.

2.3 Solar Simulator Standard

For any light source to be classified as a Solar simulator, it is tested under one of three standard. There are three organization which provide standards for a solar simulator,

- International Electrotechnical Commission (IEC 60904-9)
- American Society for Testing and Material (ASTM E927-10)
- Japanese Industrial Standard (JIS C 8904-9 (2017))

They evaluate the solar cell in three main criteria; spectral match, spatial non-uniformity of irradiance and temporal instability and based on that define the solar simulator under three classes; Class A, Class B and Class C. Hence any solar simulator is characterized by a three letter code classifying each of three criteria. The first letter classify spectral match, second letter classify spatial non-uniformity and the third letter classify temporal stability. Class A+ shows the best performance, followed by A, B and C. For example device labeled Class ABA achieve top spectral and temporal performance while medium spatial homogeneity.

Spectral Match

This is defined as how well the distribution of irradiance in different wavelength matches the natural sunlight. It can be calculated as the actual percentage of irradiance falling to the total irradiance. The solar spectrum has been divided into six different wavelength ranges and the Spectral match is calculated using

$$SM = \frac{\text{Measured Irradiance (Interval)}}{\text{Standard Irradiance (Interval)}} \quad (2.2)$$

Spatial Non-Uniformity

This is widely considered as the most challenging parameter to optimize. It measures the consistency of light intensity across a test plane and ensures there are no hot spots due to condensation of light. It is calculated from the peak (E_{\max}) and trough (E_{\min}) intensity at a test grid and is given using

$$SNU = \frac{E_{\max} - E_{\min}}{E_{\max} + E_{\min}} \times 100\% \quad (2.3)$$

Temporal Instability

In any solar simulator, the output must be stable over time, free from any arbitrary dimming or flickering. This is to ensure that no distortion or noise is added during the solar cell measurement. It is measured in the same way as SNU but in this the intensity is measured during the whole time interval of data acquisition.

The data comparing specification defined by different standards have been shown in table 2.1 and Data showing ideal spectral match defined by different standards are shown in table 2.2 and 2.3.

Table 2.1: Specification defined by different standards for Class A+, A, B and C solar simulator. Data from [6], [7], [8].

Parameters	Class	Standards		
		IEC 60904-9	JIS C 8904-9	ASTM E927-10
Spectral match	A+	0.875- 1.125	-	-
	A	0.75-1.25	0.75-1.25	0.75-1.25
	B	0.6-1.4	0.6-1.4	0.6-1.4
	C	0.4-2.0	0.4-2.0	0.4-2.0
Spatial Non- uniformity	A+	1%	-	-
	A	2%	2%	2%
	B	5%	3%	5%
	C	10%	10%	10%
Temporal Instability (Short term)	A+	0.25%	-	-
	A	0.5%	0.5%	-
	B	2%	2%	-
	C	10%	10%	-
Temporal Instability (long term)	A+	1%	-	-
	A	2%	2%	2%
	B	5%	5%	5%
	C	10%	10%	10%

Table 2.2: Target irradiance contribution per bandwidth as defined by IEC 60904-9 (2020). Data from [6].

Wavelength Interval (nm)	Required Irradiance (W/m^2)	Target Contribution (%)
300-470	14.5-18.7	16.6%
470-561	14.7-18.8	16.7%
561-657	14.6-18.8	16.7%
657-772	14.6-18.7	16.6%
772-919	14.6-18.7	16.7%
919-1200	14.6-18.8	16.7%

Table 2.3: Target irradiance contribution per bandwidth as defined by JIS C 8904-9 and ASTM E927-10. Data from [7], [8].

Wavelength Interval (nm)	Required Irradiance (W/m^2)	Target Contribution (%)
400-500	13.8-23.0	18.4%
500-600	14.9-24.9	19.9%
600-700	13.8-23.0	18.4%
700-800	11.2-18.6	14.9%
800-900	9.4-15.6	12.5%
900-1100	11.9-19.9	15.9%

2.4 Light sources for Solar Simulator

As discussed by Esen *et al.* [3] in their review paper of different light sources used for solar simulator, some of the key technologies are:

- Carbon arc - Carbon arc light is compatible with AM0 and used for space solar simulator [3, sec 3.1].
- High pressure sodium vapor and argon arc lamp - High pressure sodium lamps are used due to their long lifetime, broad spectral range and higher efficiency than previous technologies [3, sec 3.1].
- Quartz tungsten halogen lamp - Preferred due to high light intensity, low cost and usability and spectral interval that is near natural sunlight [3, sec 3.2].
- Mercury Xenon lamp - Combines ultraviolet spectrum of mercury vapour lamp and IR spectrum of xenon lamps. [3, sec 3.3]
- Xenon arc and flash lamp - Xenon has matching sunlight spectrum with high light intensity. Used in conventional solar simulator. Short life cycle and high maintenance are some disadvantages of Xenon solar simulators.

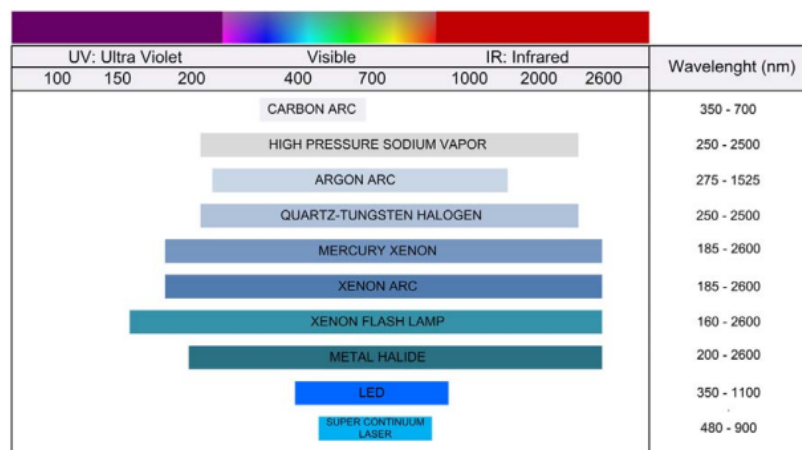

Figure 2.4: Wavelength range of light sources [3].

2.5 LED based Solar Simulator

Due to compact size, low cost and lower power consumption, LEDs are being used as light sources in newer solar simulators. They can be used in both steady

and pulsed mode. Kohraku and Kurokawa [9] used 4 colour LEDs (blue, red, infrared and white) to simulate the solar spectrum where they highlighted that AM1.5 spectrum is critical for the I-V characteristic measurement.

López-Fraguas *et al.* [10] developed a small solar simulator assembled with LEDs only. They did not use any optics and relied completely on Arduino microcontroller to electronically control its output. In this they were successful in producing a low cost class AAA solar simulator having an effective test area of 1cm^2 .

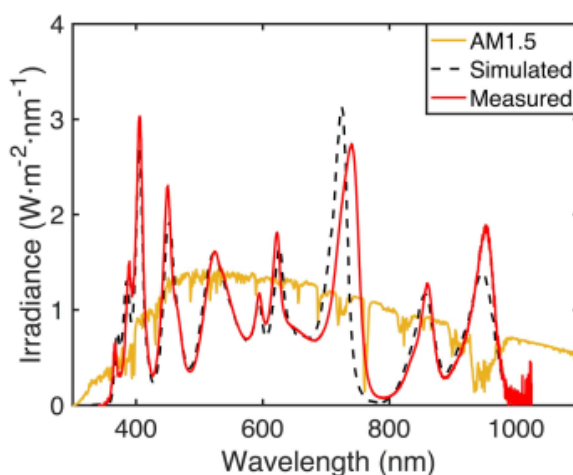
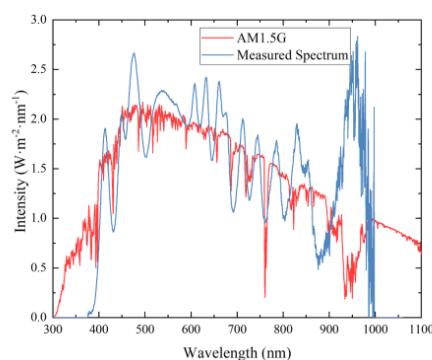

Figure 2.5: Solar simulator spectrum produced by López-Fraguas *et al.* [10]

Sun *et al.* [11] developed a class AAA solar simulator by using LEDs for different wavelength along with a hyper-hemispherical aplanatic lens to collect full aperture light of the LEDs.



(a) LED arrangement with different peak wavelength



(b) Solar simulator spectrum produced by Sun *et al.* [11]

Figure 2.6: Sun *et al.* [11] setup and results.

Apart from research project, there are also commercial LED based solar simulators which are very costly. Some of the leading market solar simulators are Ossila Solar Simulator and Newport Oriel VeraSol-2. These solar simulators are class AAA standard, but due to their high cost (in lakhs) they are often inaccessible to small scale research laboratories, highlighting the need for cost-effective alternatives.

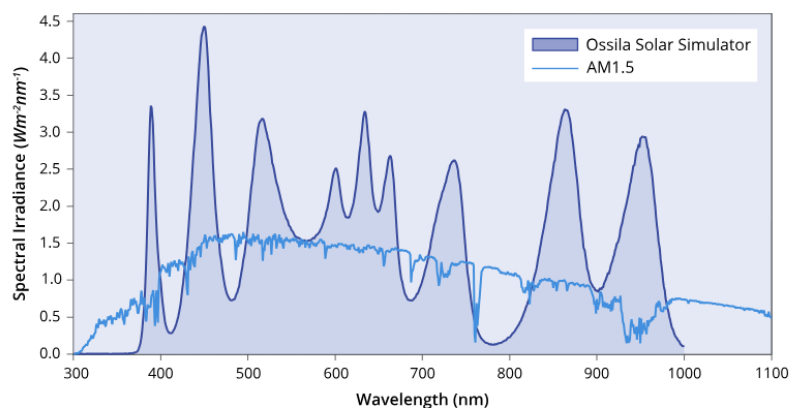

Figure 2.7: Solar simulator spectrum of Ossila Solar Simulator [12].

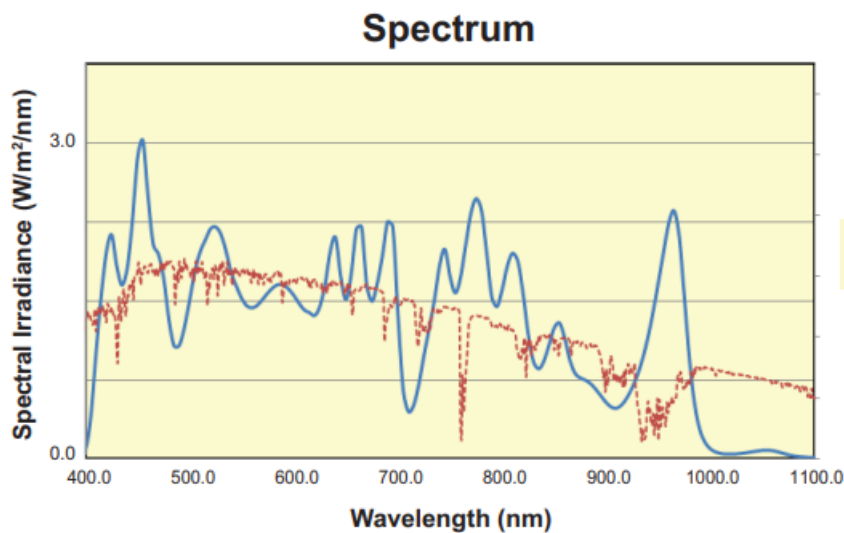

Figure 2.8: Solar simulator spectrum of Newport's VeraSol-2 [13].

Chapter 3

DEVICE ARCHITECTURE AND ASSEMBLY

In this section, we'll have an overview of the device architecture of the prototype device, why LEDs were chosen, the different optical units, the electrical system, the control system and finally the first physical prototype made.

3.1 Overview of Proposed System

The primary focus of this project is to design and assemble a low cost solar simulator using Light Emitting Diode to mimic the the solar spectrum. The prototype consists of three main subsystem:

1. The Optical Unit (consisting of LEDs, Mirror and Diffuser)
2. The Electrical Unit (consisting of Power source and driver circuit)
3. The Control Unit (consisting of Arduino Microcontroller for intensity control.)

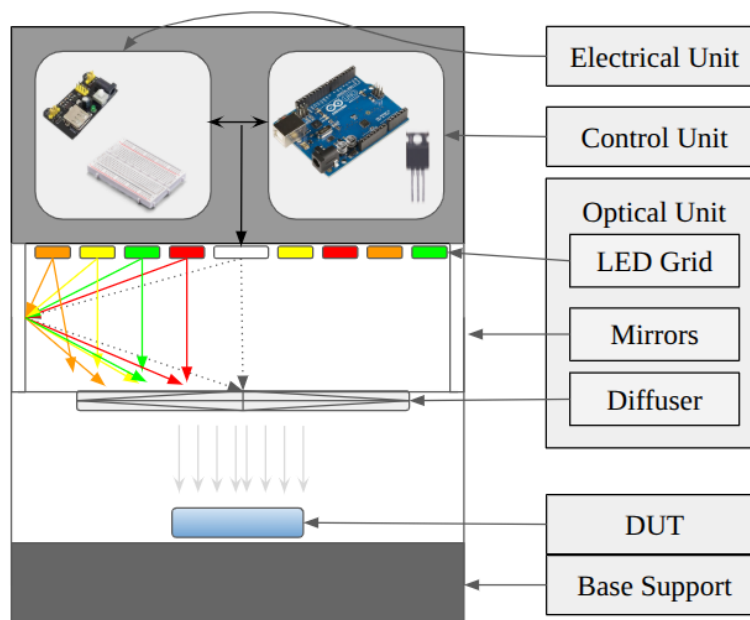

Figure 3.1: Schematics of the prototype device.

3.2 The Optical Unit

This unit consist of the light source, mirror assembly and the diffuser.

3.2.1 Selection of Light Source (LEDs)

In our prototype, we are making a simple 5 channel solar simulator, using 5 different LED sources, which are White, Green, Yellow, Orange and Red LED. This is so that we can have a broadband spectrum in visible range using the base white led and the ability to fine tune intensity in each 4 points in the spectrum near the wavelength of Green, Yellow, Orange and Red light. In the future we can increase the spectral match using more LEDs of different colours having wavelengths in between red and blue.

Why LEDs were chosen

Compared to conventional light sources, LEDs have many advantages like:

- Cost Effectiveness: LEDs are significantly cheaper than Xenon lamps.
- High Efficiency: LEDs have high energy conversion efficiency, currently converting about 80% of the electrical energy into light energy
- Long lifespan: LEDs have a long lifespan, typically exceeding 10000 hours when used under operating range
- Rapid response: LEDs are instantly illuminated without any warm up time as compared to conventional sources which take up heating time. This also helps in fast switching of LED on and off for intensity control.
- Environmentally Friendly: LED products contain no toxic substances and pose no environmental hazards.

These advantages along with the high controllability of the LEDs using PWM, gives us the ability to tune its intensity from 0% to 100%. The exact mechanism has been explained in the section 3.4.1.

Colour of Different LEDs

The colour of a particular led depends on the bandgap energy of the semiconductor used to make the LED. The specific bandgap required for each colour is achieved by varying the composition of III-IV compound semiconductor. The Red,

Orange and Yellow light are produced using AlGaInP (Aluminum Gallium Indium Phosphide) which are lattice mismatched to Gallium Arsenide (GaAs) substrate [see 14, sec 1.7]. Green and Blue LEDs are made using InGaN (Indium Gallium Nitride) that are grown on Sapphire substrate [see 14, sec 1.6]. For generating white light using LED, there are many methods. In one method two or three monochromatic colours, called complementary colours, are mixed at a certain power ratio which then result in the perception of white light. Nowadays almost all white light emitter use an LED of colour blue or ultraviolet and a photon down conversion process. The high energy photon from the primary LED is absorbed by the down converter and photon of lower energy are given out (Stokes shift). These then combine to give the white light spectrum. One such down converter material is phosphors. It is an inorganic host lattice which is then doped with some optically active rare earth ions. The industry standard uses Yttrium Aluminum Garnet (YAG), $Y_3Al_5O_{12}$ and are called YAG phosphor. Cerium (Ce) doped YAG phosphor (YAG:Ce) are used to generate white light in a typical led [see 14, sec 12]. The final result spectrum is shown in the Fig. 3.2 having a narrow blue emission from the original LED chip and a broad yellow band from the phosphor layer.

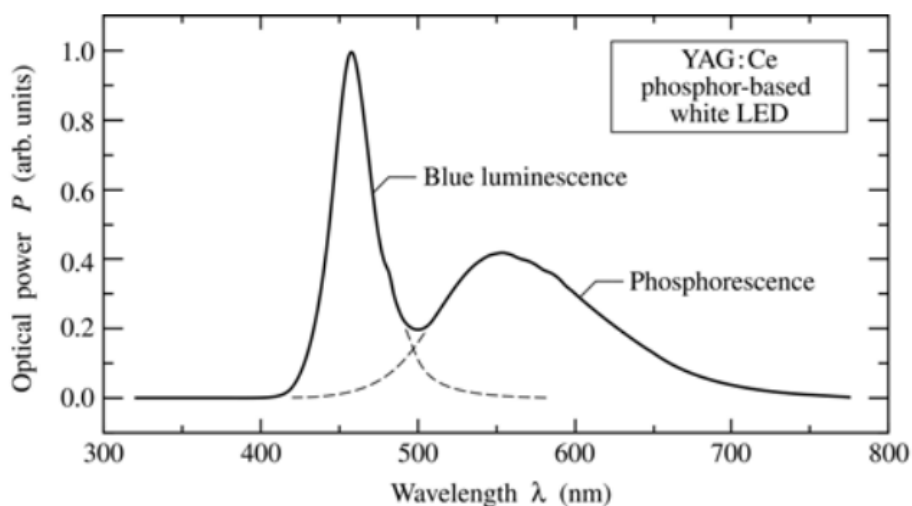

Figure 3.2: Emission spectrum of a phosphor based white LED [14].

The table for different LED light along with their technology, peak wavelength and forward voltage is shown in the table 3.1 and the graph between forward diode voltage drop and the corresponding bandgap energy of different colour led at a safe diode current of 20mA of is shown in Fig. 3.3

Table 3.1: Specification of different LEDs [14].

LED	Technology	Peak Wave-length	Forward Voltage	Reference
Red	AlGaInP	625nm	1.9 V	[see 14, sec 1.7]
Orange	ALGaInP	610nm	2.1 V	[see 14, sec 1.7]
Yellow	ALGaInP	590nm	2.1 V	[see 14, sec 1.7]
Green	GaInN/GaN	525nm	2.2 V	[see 14, sec 1.6]
Blue	GaInN/GaN	470nm	2.6 V	[see 14, sec 1.6]
White	GaInN blue LED + (YAG:Ce)	450nm	3.0 V	[see 14, sec 12]

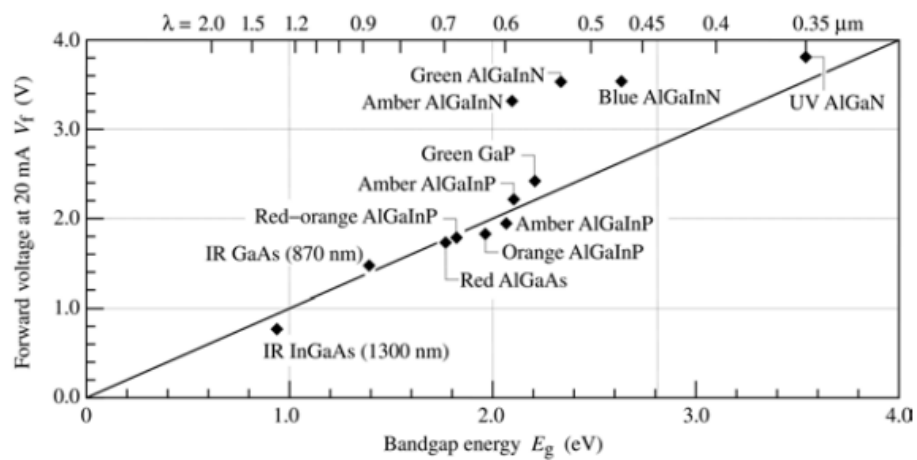
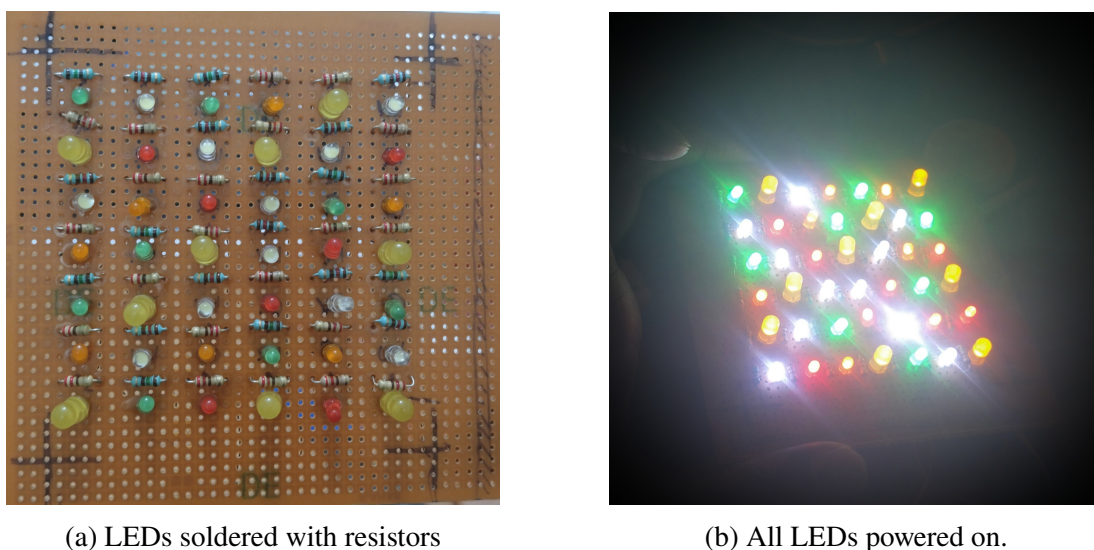

Figure 3.3: Typical diode forward voltage versus bandgap energy for LEDs [14].

3.2.2 Assembly of the LEDs

For the light source of the optical unit, a grid of different colour LEDs was soldered in a general purpose Printed Circuit Board (PCB). Each individual LED was connected in series with an appropriate resistor to limit the current flowing through it and prevent the LEDs from burnout. All the LEDs were powered by the same 5 Volts and the cathode of each colour type LEDs was soldered together and connected to the drain of the MOSFET. The LED assembly is shown in Fig. 3.4



(a) LEDs soldered with resistors

(b) All LEDs powered on.

Figure 3.4: LED grid assembly

Each colour type LEDs were individually addressable as shown in Fig. 3.5. The intensity of each colour could be controlled individually as discussed in detail in section 3.4.1.

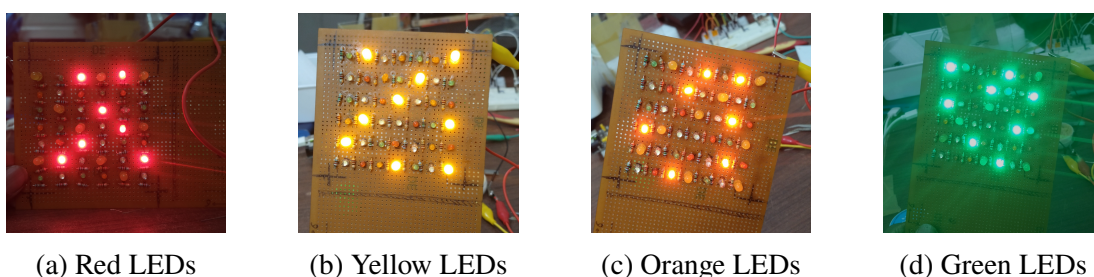

(a) Red LEDs

(b) Yellow LEDs

(c) Orange LEDs

(d) Green LEDs

Figure 3.5: LED assembly of each colour

3.2.3 Mirrors and Diffuser

LEDs differ from conventional light sources in two ways. They have relatively less power than sources like mercury or xenon lamp. And they are highly directional and emit light in a specific cone rather than all directions. To solve these two problems and ensure spatial irradiance uniformity across the test plane, we will use a mirror and diffuser setup.

Just below the LED grid, mirrors were assembled in the shape of the frustum of a pyramid. This ensured that most of the LED light reaches down instead of going outside. This also collimates and mixes the light from different colour LEDs.

It was found using a solar power meter that the light coming at the test plane was collimated and had a spatial non-uniformity percentage of around 2.5% and adding or removing the diffuser did not had any major impact in its intensity uniformity. However for future simulator devices using relatively high power LEDs, a subsequent diffuser assembly can be added to better mix the colours and to make the beam uniform.

For this a Hexagonal Micro Lens Array (MLA), also known as lenticular diffuser, can be used in the smaller base of the frustum. Unlike traditional diffusers which rely on scattering and absorption, The MLA used refractive properties to redistribute the incident light. The hexagonal packing of these lenses maximizes the fill factor. This whole setup eliminates the hotspot characteristics of discrete high power LED sources.

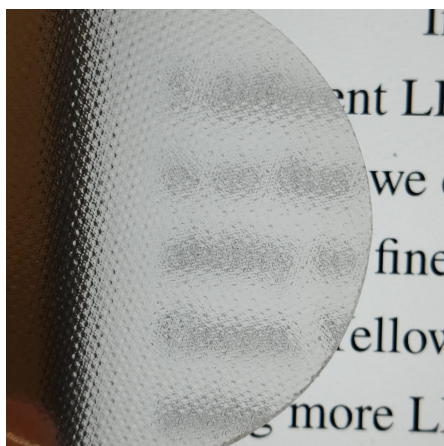

(a) Diffusion of light by the Micro Lens Array

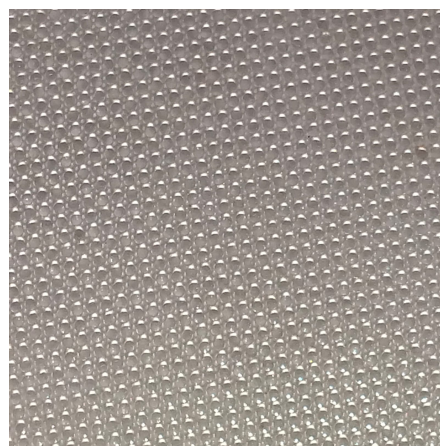

(b) Zoomed image of the Lens Array, showing the closed hexagonal packing

Figure 3.6: Hexagonal Micro Lens Array Diffuser

3.3 Electrical Unit

For providing power to the module, an old smartphone's charger is used. This charger brick is essentially an AC-DC Switch Mode Power Supply unit rated at 5V/2A. This unit converts the typical household mains voltage of 220V AC into a stable 5V DC output with a maximum output current of 2A.

Calculation of Current limiting resistor

The LEDs are connected to a constant voltage source through a limiting Resistance R_{limit} whose value is calculated using the Ohm's Law formula:

$$R_{limit} = \frac{V_s - V_f}{I_{led}}$$

where

- R_{limit} is the limiting resistance being used to prevent the LED from burning
- V_f is the forward voltage drop of particular LED
- V_s is the Constant source Voltage, here 5 volts using the breadboard power supply unit
- I_{led} is the forward current of led, here it is being restricted to 20mA.

The constant 5V DC source and resistance combination keeps the forward current of LEDs within the operating range, preventing thermal runaway and ensuring the longevity of the LEDs.

3.4 Control Unit

The control unit is responsible for controlling the intensity of each LED. This is done using MOSFETs and an Arduino Uno microcontroller board, as discussed in the next sections.

MOSFET as a switch

To control the intensity of each individual LED, we will use a low side switching configuration of a MOSFET. A MOSFET (Metal Oxide Semiconductor Field-effect Transistor) is a solid state semiconductor device that has three working

terminals namely Drain, Gate and Source. It can act as a switch depending on the voltage difference between two of its terminal. Based on the biased voltage provided, a MOSFET can act as a switch or an amplifier. First is the Cutoff region with no drain current flow. It act as an open switch (OFF state). Second is the Ohmic region where it act as Voltage controlled resistor. Here it act as closed switch (ON state). Finally in the Saturation region where drain current remain constant not depending on the drain source voltage and here it act as a linear amplifier.

For our purpose, we will use its fast switching characteristic to drive the LED. Some of the advantages of MOSFET which makes it suitable for our requirement are its infinite input impedance, so it requires almost no input current to control the load current, fast switching speed and very compact size.

In our prototype, we have used BS170 N-Channel small signal MOSFET. They can handle a maximum of 60V Drain-source voltage and can be used to drive circuits requiring up to 500 mA DC. It has a low gate threshold voltage and hence can be driven directly by the Arduino's 5V logic levels [see 15].

In the low side switching configuration, we place the N channel MOSFET between the negative terminal of load (in our case the cathode side of the LED) and the Ground as illustrated in Fig. 3.7.

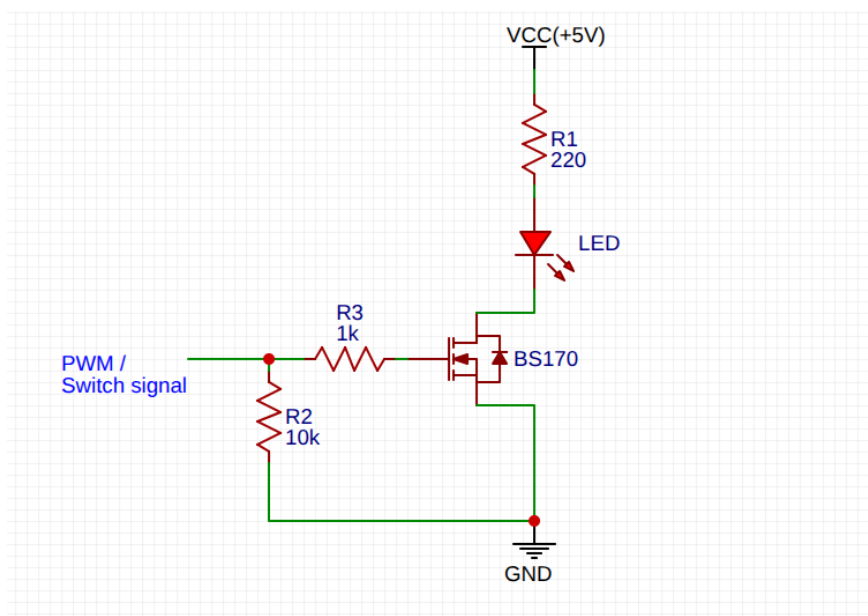

Figure 3.7: Circuit diagram of a single LED driver circuit using MOSFET. Made with EasyEDA [16]

The main components of the circuit are as follows:

1. R1 (220 Ω) is a current limiting resistor to protect the LED as calculated in

section 3.3.

2. R2 (10k Ω) is a pull down resistor. It prevent the MOSFET from turning on randomly while the switch signal is disconnected or resetting.
3. R3 (1k Ω) protects the control signal source from current spikes during the charging of MOSFET gate capacitance.
4. VCC (+5V) is the 5 volt source which drives the current in LED

3.4.1 PWM based LED Intensity Control

In the last section we discussed about using MOSFET as a switch. But it can only turn the LED either ON or OFF. But to control the intensity of LEDs using the switching feature of MOSFET, in the input signal of Gate terminal instead of a square wave, we will provide a PWM (Pulse Width Modulated) Signal. It provides an analog behavior by changing the digital output between high and low states with different width, while the frequency stays constant. This effectively controls the average power delivered to a load.

Since LEDs have low inertia (the time it takes to turn on the LED), they can be very efficiently controlled using a PWM signal without any flickering if the frequency of PWM signal is significantly high [see 17]. Apart from LED luminous intensity, LED chromaticity also depends on the current flowing through it. Therefore to make sure that the LED colour is not changed during operation, it is necessary to drive it with constant current. And by using a PWM signal, the average current in the LED can be changed, changing the light intensity, without changing the real LED current, which governs the colour of particular LED [see 18].

By using PWM signal, we are controlling the time averaged power delivery to the LED. The total energy delivered over a time period T is the integral of the instantaneous power, given by

$$P_{avg} = \frac{1}{T} \int_0^T P(t) dt \quad (3.1)$$

By controlling the Duty Cycle, we control the average power delivered to the load which is then given by

$$P_{avg} = P_{peak} \times D \quad (3.2)$$

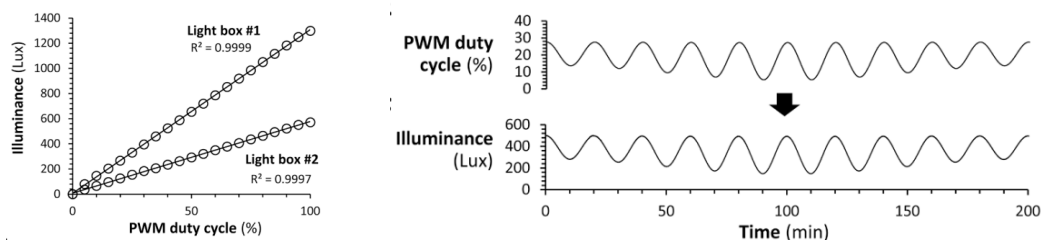

(a) Relationship between light output and PWM duty cycle.

(b) Graph showing relationship between a time varying PWM signal and the corresponding illuminance of the LED light source.

Figure 3.8: Plots showing linear Relationship between PWM duty cycle and illuminance [19].

Hence a 25% duty cycles means that only 25% of the photons per second are delivered as compared to full power, which result in 0.25 times of the Peak Irradiance. Burton *et al.* [19] showed that the light output is directly proportional to the PWM duty cycle for the measured interval (2% - 99 %). Therefore by adjusting the duty cycle, the average current supplied to the LED changes linearly. This allows for precise linear control of Irradiance. The graph showing linear relation between PWM signal and illuminance is shown in Fig. 3.8.

To provide a controllable PWM signal, we have used an Arduino UNO microcontroller. This has been explained in next section.

3.4.2 Arduino UNO setup

The main control unit for this solar simulator is the Arduino UNO development board. It is a popular microcontroller board and uses a single chip microcontroller created by Atmel Microcontrollers named ATmega328P. The generation of PWM signal is handled by the internal hardware timers of the microcontroller. These timers operate independently of the central processing unit. The core mechanism consists of an internal 8-bit counter register. The register counts the clock cycle, which is then compared to a set value in an Output Compare Register (OCR_nx). This toggles the Output Compare (OC_nx) pin to create pulses of varying width at a fixed frequency. In this way by loading a value between 0-255 in OCR register, pulses of particular width can be generated [see 20, page 74].

The pins of ATmega328P are connected to the Arduino pins as shown in Fig. 3.9.

There are 14 pins which can act as a digital input/output pins numbered 0-13. For our purpose, we need the pins producing PWM signals. There are six such pins. They are located at the indices 3, 5, 6, 9, 10, 11. We will use these 6 pins to control 6 different

ARDUINO PINS		ATMEGA328P PIN DETAILS WITH ARDUINO FUNCTIONS						ARDUINO PINS	
Reset	(PCINT14/RESET)	PC6	Pin1	Pin28	PC5	(ADC5/SCL/PCINT13)	Analog Input 5		
Digital Pin 0 (RX)	(PCINT16/RXD)	PD0	Pin2	Pin27	PD4	(ADC4/SDA/PCINT12)	Analog Input 4		
Digital Pin 1 (RX)	(PCINT17/TXD)	PD1	Pin3	Pin26	PD3	(ADC3/PCINT11)	Analog Input 3		
Digital Pin 2	(PCINT18/INT0)	PD2	Pin4	Pin25	PC2	(ADC2/PCINT10)	Analog Input 2		
Digital Pin 3 (PWM)	(PCINT19/OC2B/INT1)	PD3	Pin5	Pin24	PC1	(ADC1/PCINT9)	Analog Input 1		
Digital Pin 4		PD4	Pin6	Pin23	PC0	(ADC0/PCINT8)	Analog Input 0		
Vcc		Vcc	Pin7	Pin22	GND		GND		
GND		GND	Pin8	Pin21	AREF		Analog Reference		
Crystal	(PCINT6/XTAL1/TOSC1)	PB6	Pin9	Pin20	AVCC		Vcc		
Crystal	(PCINT7/XTAL2/TOSC2)	PB7	Pin10	Pin19	PB5	(SCK/PCINT5)	Digital Pin 13		
Digital Pin 5 (PWM)	(PCINT21/OC0B/T1)	PD5	Pin11	Pin18	PB4	(MISO/PCINT4)	Digital Pin 12		
Digital Pin 6 (PWM)	(PCINT22/OC0A/AIN0)	PD6	Pin12	Pin17	PB3	(MOSI/OC2A/PCINT3)	Digital Pin 11(PWM)		
Digital Pin 7	(PCINT23/AIN1)	PD7	Pin13	Pin16	PB2	(SS/OC1B/PCINT2)	Digital Pin 10(PWM)		
Digital Pin 8	(PCINT0/CLKO/ICP1)	PB0	Pin14	Pin15	PB1	(OC1A/PCINT1)	Digital Pin 9(PWM)		

Figure 3.9: ATmega328P Pin details with Arduino functions [21].

types of LEDs, varying their intensities.

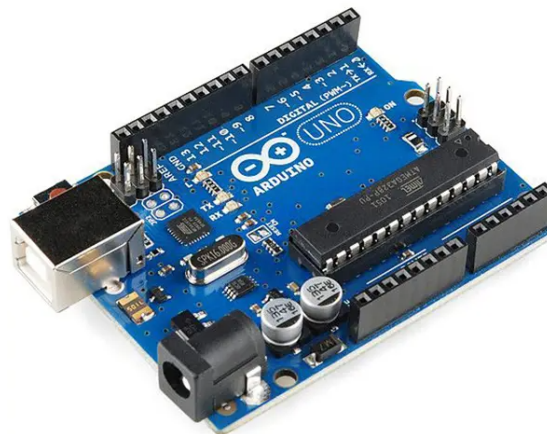

Figure 3.10: Arduino UNO Development board [22].

The code for Arduino is written in an IDE (Integrated Development Environment). The interface of such IDE is shown in Fig. 3.11. For changing the width of pulse, we use the `analogWrite()` function. It takes the values 0-255 as input and gives a signal of width 0% to 100%, mapping 0 to 0% and 255 to 100%.

The standard frequency of PWM is approximately 490/980Hz. For creating a smooth pulse, we can directly manipulate the Timer Control Register from the IDE. This allow us to generate ultrasonic PWM frequencies (around 31.25 kHz). This fast signal appears as a continuous steady light to the photovoltaic cells and prevent any flickering or noise



Figure 3.11: Arduino IDE (Integrated Development Environment) interface [22].

which may appear due to low frequency wave.

3.5 Final Device Assembly

3.5.1 Circuit Schematics

In our prototype circuit, we expanded the circuit of figure 3.7 to 5 different colour LEDs instead of 1.

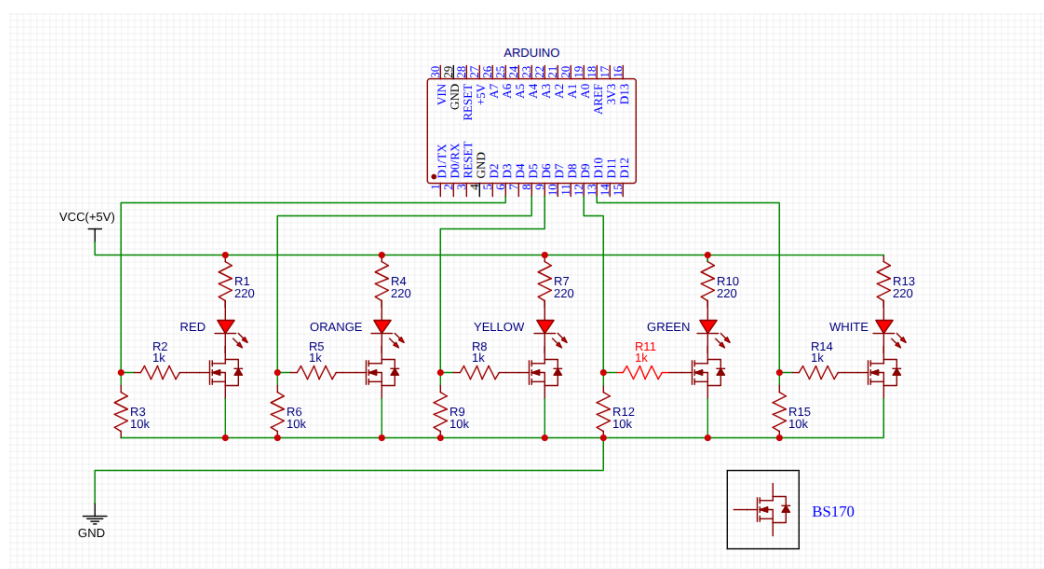

Figure 3.12: Schematic of a 5 channel LED driver circuit using MOSFET and Arduino.

The schematics in the Fig. 3.12 shows the standard driver circuit implemented for each channel. Each LED resistor pair represents a single colour LED type. Made with EasyEDA [16]

3.5.2 Physical Prototype

The figure 3.13 shows the actual experimental setup for validation. The setup includes the Arduino microcontroller, the MOSFET switching array and the LED grid, along with the mirror assembly and the encasing made from acrylic sheet.

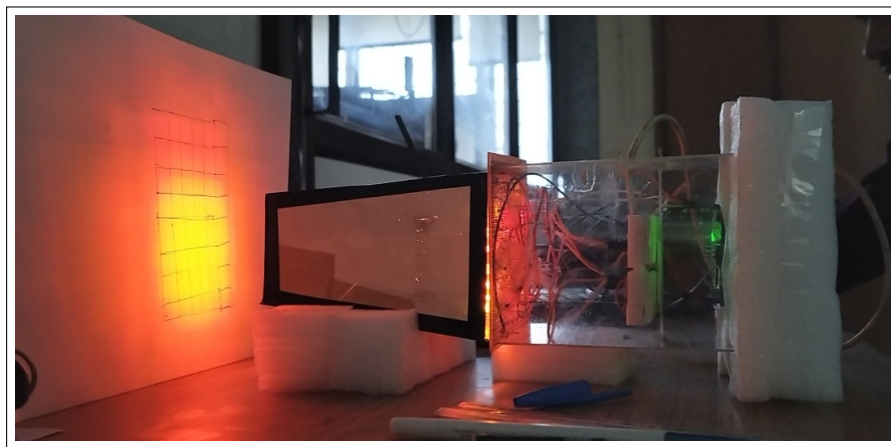

Figure 3.13: Physical Prototype

Arduino Code

The code to control the LEDs can be found in Appendix A.

Chapter 4

EXPERIMENTAL VERIFICATION

To characterize the Solar simulator under international standards like IEC 60904-9 standard (see 2.3), its three parameters, i.e. the spectral match, spatial non-uniformity and temporal instability must be assessed. However due to constraints in availability of testing devices, specifically a spectrum analyzer, it was not possible to characterize the spectral feature of this solar simulator. A solar power meter (Tenmars TM-207 Solar Power Meter) was made available. Therefore only its spatial non-uniformity test was done. The testing device and results are discussed below.

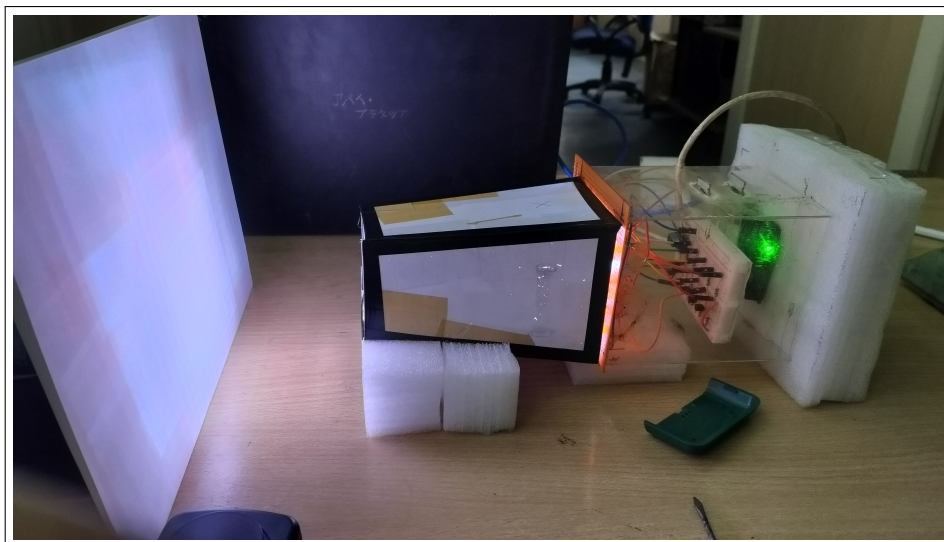

Figure 4.1: Device test setup in horizontal position.

Solar Power Meter

For measuring the spatial non-uniformity of our device, we used a Solar Power Meter from Tenmars Electronics Co., LTD, model TM-207 (see Fig. 4.2). It is a handheld, high precision solar power digital meter that can be used to measure the solar radiation and energy transmission. It has a detached external sensor connected to the main body through a 1.5 meter wire and gives the measurement in W/m^2 or BTU (British Thermal Unit)/ $(\text{ft}^2 * \text{h})$. The test was done in a dark room and at ambient temperature. For easy accessibility, the device was put down in horizontal mode. Through this digital meter, we were able to test a few things like

- The intensity of light vs applied PWM signal
- Peak intensity in the test plane vs Distance of measurement
- Peak Intensity of each colour type LED
- Spatial intensity profile for the test plane.



Figure 4.2: Tenmars TM-207 Solar Power Meter

Intensity vs PWM signal

We were able to show the relation between the light output intensity and input PWM signal duty cycle as also discussed in Burton *et al.* [19]. The Arduino digital output pins have a PWM duty cycle range from 0 to 255 where 0 means the output is 0% duty cycle (i.e. constantly 0 Volt or LOW signal) and 255 means the output is 100% duty cycle (i.e. constantly 5 Volts or HIGH signal). The intermediate PWM value as fraction of 255 corresponds to same fraction in duty cycle. For our measurement, all white LEDs were turned on and the intensity were measured in Duty cycle values of 50, 100, 150, 175, 200, 225 and 255. The test plane was at 0 cm. The peak intensity measured for a 100% duty cycle for white light was 7.8 W/m^2 . The PWM duty cycle, Duty cycle percentage, absolute intensity measurement and intensity percentage from peak intensity were tabulated in table 4.1 and the graph between Intensity percentage and PWM duty cycle percentage was plotted as shown in in Fig. 4.3.

Table 4.1: PWM signal of varying duty cycle and its corresponding intensity

PWM Signal (0-255)	Intensity W/m ²	Duty cycle (%)	Intensity (%)
50	1.3	19.61	16.67
100	2.9	39.22	37.18
150	4.5	58.82	57.69
175	5.3	68.63	67.95
200	6.1	78.43	78.21
225	7	88.24	89.74
255	7.8	100	100

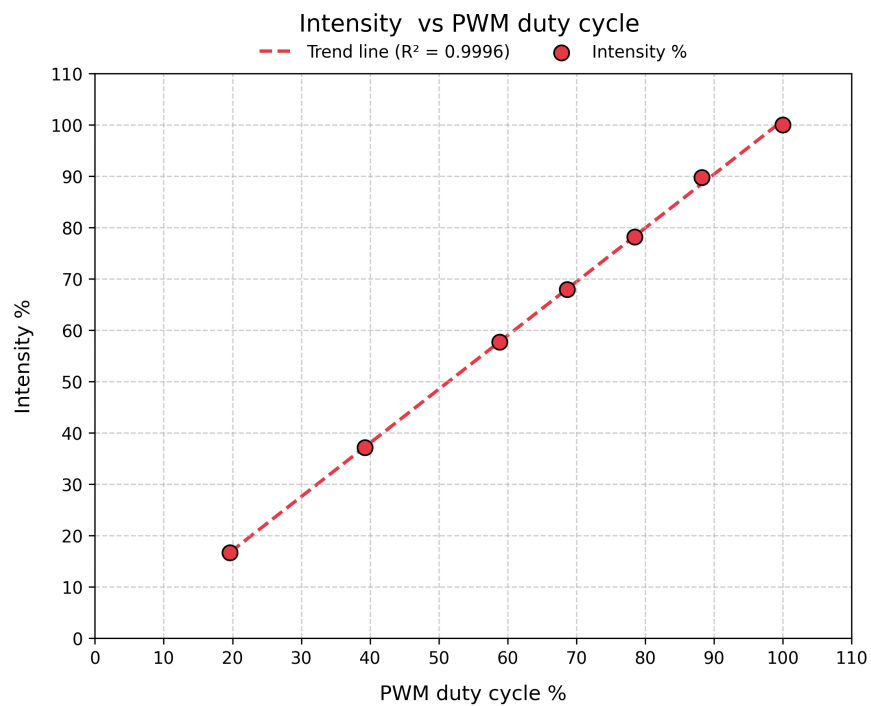

Figure 4.3: Intensity vs PWM signal duty cycle

Intensity vs Distance

The relation between Intensity of light versus the distance of test plane was also measured using the solar meter. It was found that intensity drops steeply within the measured 0 cm to 8 cm range. The value of distance and light intensity were tabulated in table 4.2 and the graph between Intensity vs distance were plotted as shown in in Fig. 4.4.

Table 4.2: Distance of test plane and intensity values

Distance (cm)	Intensity W/m^2
0	13
1	12.4
2	11.5
3	10
4	8.7
5	7.5
6	6.2
7	5.1
8	4.2

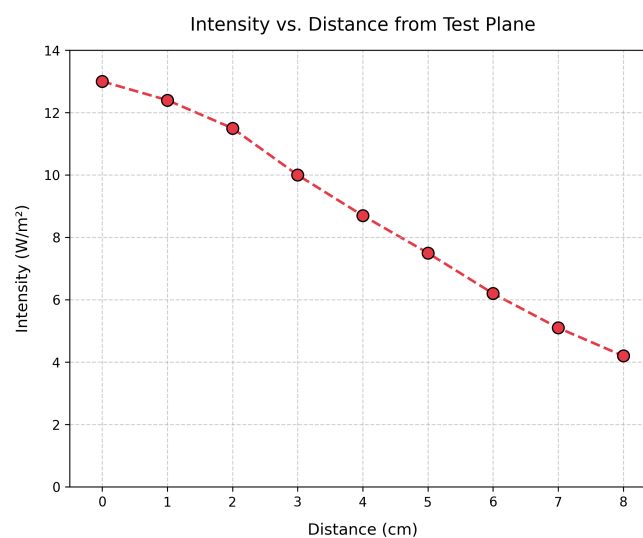

Figure 4.4: Intensity vs distance plot

LED colour vs Peak Intensity

Peak light intensity for each colour LED was also measured using the solar meter. For this, all LEDs were turned off, then one by one all the LEDs of each colour type were turned on with full power (100% duty cycle). The light colour and their respective peak intensity were tabulated in table 4.3 and were plotted as shown in in Fig. 4.5.

Table 4.3: LEDs of different colour and their peak intensity

LED Colour	Intensity W/m ²
White	7.8
Red	1.5
Yellow	0.2
Orange	0.5
Green	2.3

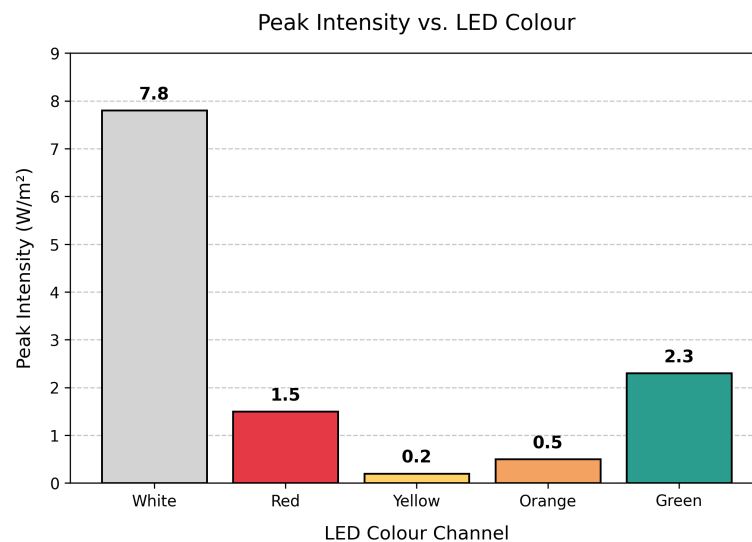

Figure 4.5: Colour vs intensity plot.

In the LED grid, out of 42 LEDs, 11 are of white, 7 are red, 9 are yellow, 7 are orange and 8 are green. It can be seen that white LEDs have the maximum light output. This can be explained as the Tenmars TM-207 solar meter has a spectral response for the wavelength range of 400 to 1100 nm. It is calibrated for the broadband AM1.5G spectrum and not for the narrowband emission of coloured LEDs. Also adding

to the fact that number of white LEDs is higher than other. Hence the energy output for white light is significantly higher than single coloured LEDs. The TM-207 cannot be used to accurately balance the irradiance of individual LED channel and therefore a spectrometer must be used to get the true energy output values.

4.1 Spatial Non-Uniformity

Out of the three parameters for characterizing a solar simulator, namely the spectral match, spatial non-uniformity and temporal instability, only the spatial non-uniformity could be tested using the Tenmars TM-207 solar meter. For this, first a grid was setup over the test plane. The grid consists of a 5×5 matrix of equal area cells. Each cell represent a physical measurement taken by the sensor at a specific (x,y) coordinate on the test plane. The sensor was placed in each cell position and the corresponding value of intensity was measured. Once all the 25 values were measured, it was then plotted to create a 2-dimensional grid of light intensity. From the values, the maximum irradiance value (E_{\max}) and minimum irradiance value (E_{\min}) were recorded and the spatial non-uniformity percentage was then calculated using the standard formula as given by ASTM and IEC, as:

$$\text{SNU} = \frac{E_{\max} - E_{\min}}{E_{\max} + E_{\min}} \times 100\% \quad (4.1)$$

For our testing purpose, the white light LED was turned on with full intensity, the sensor was placed at 0 cm and the intensity for each cell area was measured. The corresponding 2-D Spatial irradiance heatmap was then generated using matplotlib and given in Fig. 4.6.

Analysis

In the Fig. 4.6, the colour gradient maps directly to the light intensity at that cell and highlight the region with high intensity (as shown by darker blue colour) and the regions with relatively low intensity (as shown by lighter green colour). There is a smaller box of 3×3 grid as shown in the red square, which is our designated test area. In any solar simulator, the entire test plane is rarely uniform and this smaller red box defines the specific boundary where the actual solar cell will be placed for the testing purpose.

For calculating SNU percentage, the minimum and maximum values from the 2-D map inside the red box was recorded and found to be:

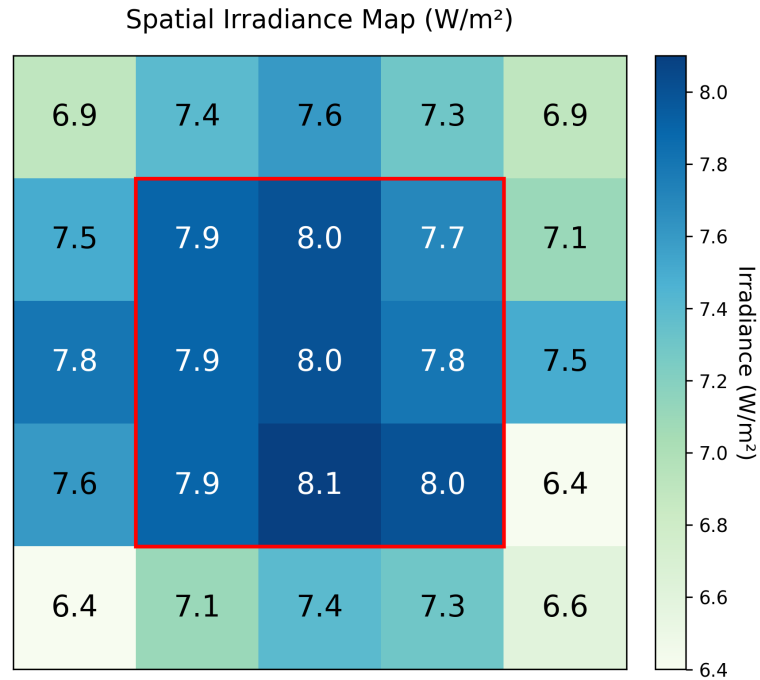

Figure 4.6: Spatial Irradiance Heatmap

- Maximum value (E_{\max}): 8.1
- Minimum value (E_{\min}): 7.7

Putting it in the formula, we get:

$$\text{SNU} = \frac{8.1 - 7.7}{8.1 + 7.7} \times 100 = \frac{0.4}{15.8} \times 100 \approx 2.53\% \quad (4.2)$$

Hence we get a 2.53 % spatial non-uniformity, which corresponds to a **Class B** rating for spatial uniformity as per standards. The **B** rating can be explained from the fact that total light power is quite low (a few Watt/m²) and therefore even a tiny variation of 0.4 Watt/m² give rise to this high percentage. If high power LEDs are used having the total power output in hundreds of Watt/m² along with diffuser systems, then this percentage will be significantly reduced.

So we were able to calculate the spatial non-uniformity percentage along with other parameter like the intensity vs PWM duty cycle, distance and colour. The further work is discussed in the next chapter.

Chapter 5

FUTURE SCOPE

The main objective of this project, which was to design and assemble a cost effective LED based solar simulator that should be capable of satisfying the Class AAA standard is far from over. Under the apparatus constraints, only its spatial non-uniformity parameter could be tested. Therefore this project leaves a great deal of things that could be further developed.

The most prominent being the availability of a fiber optic spectrometer to capture the intensity of light at different wavelength range. This would help to first characterize the light colour vs peak intensity for each LED channel. This can then be used to calculate the exact spectral mismatch for the current 5 channel array and to calibrate the positioning and intensity of each colour LED type. Further this helps in getting the right LEDs so the net output light intensity at the test plane is near the AM1.5G standard of 1000 Watt/m². The current peak intensity reading from the Tenmars solar meter is only around 13 Watt/m², which would correspond to 0.013 Sun and is insufficient for testing any solar cell. Hence more focus is needed to get both the spectral match and intensity calibration for making the solar simulator workable for testing solar cells.

Once the solar simulator is calibrated correctly in the visible light spectrum, it can then be further developed to include Near Infrared (NIR) and UltraViolet (UV) spectra. By including NIR LEDs and UV LEDs of appropriate wavelengths, the spectral match can be further improved. It would provide a more accurate and real testing environment for the next generation solar cells like the perovskite and tandem solar cells, which have a broad spectrum response.

Another major feature that could be added to the device is to use a Closed Loop feedback control. Currently, the device is operated in an open loop configuration as the PWM values are set by the user for each LED. An upgrade to this can be to use the live output from the spectrometer to feed data into the microcontroller, which then can automatically adjust the PWM signal going into each LED array to match the spectrum and intensity profile. An algorithm could be developed which can efficiently do this process and connect the output from the spectrometer and the input to the arduino microcontroller. This could be a project on its own.

One last improvement that could be included in the device is the use of an

active thermal management. Currently, the device uses less than 500 mA of current when operating at 100% duty cycle and the current passing through each mosfet is well below 100 mA. The BS170 MOSFET used in this device is rated for 500 mA continuous drain current and hence is operating below 20% of the component's maximum limit. This means that the MOSFET remains cool during the operation and we do not see any thermal degradation in the working of the device. However in future if high power LEDs are used to better match the AM1.5G standard intensity, an active thermal cooling mechanism must be added to it. This will prevent any fluctuation in the output of LEDs due to heating.

These additions would definitely help to achieve the Class AAA standard for the LED based solar simulator. Furthermore, excluding the procurement cost of a spectrometer, all of these upgrades could be done at a cost well below that of any commercial-grade LED solar simulator.

Chapter 6

CONCLUSION

We designed a physical prototype of a 5 channel LED solar simulator. This include the five colour LEDs, with white light providing the broadband spectrum in visible light range and the four individual colour LEDs (Red, Yellow, Orange and Green) providing the fine tuning of the spectrum. Mirrors were assembled to collimate the beam. The hardware part used a Low-Side N channel MOSFET switching circuit controlled by an Arduino UNO microcontroller. This system allowed for precise Pulse Width Modulation (PWM) intensity control. This proves that the intensity output can be electrically tuned without using any mechanical filters.

The prototype was then validated. Availability of a solar power meter allowed us to find its spatial non-uniformity percentage. The test plane was mapped using the intensity heatmap and we secured a Class B spatial non-uniformity rating (2.53%). Other helpful parameters like the intensity vs distance profile were also recorded which will be helpful in future solar cell testing. We were also able to verify the PWM signal based intensity control of the LEDs.

A key achievement of this work was the economic feasibility of the design. A rough cost analysis reveals that the whole prototype (without the characterization and testing devices), along with recommended improvements in the spectral domain can be made well below the cost of commercial simulators.

Ultimately, the prototype serves as a foundational first step in making an economical solar simulator. We were only able to test the spatial uniformity of our simulator, but with an appropriate spectrometer and high power LED systems, we can match the solar spectrum. The current control unit can easily be adapted for such high-power LED systems. Integrating these high power channels, along with NIR and UV LEDs will enable us to meet the Class AAA AM1.5G standard. This low-cost simulator will then be fully capable of providing a realistic testing environment for solar cells which would be suitable for small scale research and educational laboratories.

REFERENCES

- [1] *IEC 60904-3: Photovoltaic devices - part 3: Measurement principles for terrestrial photovoltaic (pv) solar devices with reference spectral irradiance data*, Geneva, Switzerland: International Electrotechnical Commission, 2019.
- [2] J. Nelson, *The Physics of Solar Cells*. London: Imperial College Press, 2003, ISBN: 978-1860943409.
- [3] V. Esen, Ş. Sağlam, and B. Oral, "Light sources of solar simulators for photovoltaic devices: A review," *Renewable and Sustainable Energy Reviews*, vol. 77, pp. 1240–1250, 2017, ISSN: 1364-0321. DOI: <https://doi.org/10.1016/j.rser.2017.03.062>. [Online]. Available: <https://www.sciencedirect.com/science/article/pii/S1364032117303787>.
- [4] *Astm g173-03(2020): Standard tables for reference solar spectral irradiances: Direct normal and hemispherical on 37° tilted surface*, West Conshohocken, PA: ASTM International, 2020. [Online]. Available: <https://www.astm.org/g0173-03r20.html>.
- [5] A. Buchroithner, B. Gerl, R. Felsberger, and H. Wegleiter, "Design and operation of a versatile, low-cost, high-flux solar simulator for automated cpv cell and module testing," *Solar Energy*, vol. 228, pp. 387–404, 2021, ISSN: 0038-092X. DOI: <https://doi.org/10.1016/j.solener.2021.08.068>. [Online]. Available: <https://www.sciencedirect.com/science/article/pii/S0038092X21007325>.
- [6] *IEC 60904-9:2020 photovoltaic devices - part 9: Classification of solar simulator characteristics*, Geneva, Switzerland: International Electrotechnical Commission, 2020.
- [7] *ASTM e927-10: Standard specification for solar simulation for terrestrial photovoltaic testing*, Reapproved 2015, West Conshohocken, PA: ASTM International, 2010.
- [8] *JIS c 8904-9:2017 photovoltaic devices - part 9: Solar simulator performance requirements*, Tokyo, Japan: Japanese Industrial Standards Committee, 2017.
- [9] S. Kohraku and K. Kurokawa, "A fundamental experiment for discrete-wavelength led solar simulator," *Solar Energy Materials and Solar Cells*, vol. 90, no. 18, pp. 3364–3370, 2006, 14th International Photovoltaic Science and Engineering Conference, ISSN: 0927-0248. DOI: <https://doi.org/10.1016/j.solmat>.

- 2005.09.024. [Online]. Available: <https://www.sciencedirect.com/science/article/pii/S0927024806002595>.
- [10] E. López-Fraguas, J. M. Sánchez-Pena, and R. Vergaz, “A low-cost led-based solar simulator,” *IEEE Transactions on Instrumentation and Measurement*, vol. 68, no. 12, pp. 4913–4923, 2019. DOI: 10.1109/TIM.2019.2899513.
- [11] C. Sun, Z. Jin, Y. Song, *et al.*, “Led-based solar simulator for terrestrial solar spectra and orientations,” *Solar Energy*, vol. 233, pp. 96–110, 2022, ISSN: 0038-092X. DOI: <https://doi.org/10.1016/j.solener.2022.01.001>. [Online]. Available: <https://www.sciencedirect.com/science/article/pii/S0038092X22000019>.
- [12] “Solar simulator - class aaa system for small-area solar cells.” Accessed: Dec. 2025, Ossila Ltd. (2024), [Online]. Available: <https://www.ossila.com/products/solar-simulator>.
- [13] *Oriel verasol-2 led class aaa solar simulator datasheet*, DS-092002, Rev. 06, Newport Corporation, 2019. [Online]. Available: https://www.newport.com/medias/sys_master/npresources/hf5/hd8/9954415476766/DS-092002%20Verasol%20Solar%20Simulator%20Datasheet/DS-092002-Verasol-Solar-Simulator-Datasheet.pdf.
- [14] E. F. Schubert, *Light-emitting diodes*. Cambridge university press, 2006.
- [15] *Field effect transistor - n-channel, enhancement mode (bs170, mmbf170) data sheet*, Rev. 8, onsemi, 2024. [Online]. Available: <https://www.onsemi.com/download/data-sheet/pdf/mmbf170-d.pdf>.
- [16] “Easyeda: A web-based eda tool for circuit design, simulation and pcb design.” Accessed: Dec. 2025, EasyEDA. (2024), [Online]. Available: <https://easyeda.com/>.
- [17] A. V. Kudryashov, A. S. Kalinina, and G. N. Yagovkin, “Pulse width modulated led light control and vision adaptation,” in *2017 International Conference on Industrial Engineering, Applications and Manufacturing (ICIEAM)*, 2017, pp. 1–4. DOI: 10.1109/ICIEAM.2017.8076145.
- [18] *Automotive high brightness led control based on the mc9s08mp16 microcontroller*, AN4105, Rev. 0, NXP Semiconductors, 2010. [Online]. Available: <https://www.nxp.com/docs/en/application-note/AN4105.pdf>.

- [19] A. H. Burton, Q. Bai, and E. A. Burton, "Sinusoidal analysis reveals a non-linear and dopamine-dependent relationship between ambient illumination and motor activity in larval zebrafish," *Neuroscience Letters*, vol. 761, p. 136 121, 2021, ISSN: 0304-3940. DOI: <https://doi.org/10.1016/j.neulet.2021.136121>. [Online]. Available: <https://www.sciencedirect.com/science/article/pii/S0304394021004997>.
- [20] *Atmega328p 8-bit avr microcontroller with 32k bytes in-system programmable flash (automotive)*, Atmel-7810D, Rev. 7810D-AVR-01/15, Atmel Corporation, 2015. [Online]. Available: https://ww1.microchip.com/downloads/en/DeviceDoc/Atmel-7810-Automotive-Microcontrollers-ATmega328P_Datasheet.pdf.
- [21] S. Z. Nasir. "Atmega328p pinout, configuration, features & datasheet." Accessed: Dec. 2025, ComponentsInfo. (2024), [Online]. Available: <https://www.componentsinfo.com/atmega328p-pinout-configuration-datasheet/>.
- [22] "Arduino open-source electronics platform: Hardware and software." Accessed: Dec. 2025, Arduino. (2024), [Online]. Available: <https://www.arduino.cc/>.

Appendix A

Arduino Code

```
1 int redPin = 3;
2 int orangePin = 5;
3 int yellowPin = 6;
4 int greenPin = 9;
5 int whitePin = 10;
6 // int greenPin = 5;
7
8 int brightness = 0;
9
10 void setup(){
11     // pinMode(pin number, [IN|OUT]PUT)
12     pinMode(redPin, OUTPUT);
13     pinMode(orangePin, OUTPUT);
14     pinMode(yellowPin, OUTPUT);
15     pinMode(greenPin, OUTPUT);
16     pinMode(whitePin, OUTPUT);
17
18     analogWrite(redPin, 0);
19     analogWrite(orangePin, 0);
20     analogWrite(yellowPin, 0);
21     analogWrite(greenPin, 0);
22     analogWrite(whitePin, 0);
23
24
25     Serial.begin(9600);
26     // Serial.println("EnterValue: ");
27 }
28
29 void loop(){
30     // to check if serial have new data
31     if (Serial.available() > 0){
32         char colour = Serial.read();
33
```

```

34 // String command = Serial.readStringUntil('\n');
35 // command.trim();
36 // if (command.length() > 0){
37
38 brightness = Serial.parseInt();
39 brightness = constrain(brightness,0,255);
40
41 switch(colour){
42     case 'r' : analogWrite(redPin, brightness); break;
43     case 'o' : analogWrite(orangePin, brightness); break;
44     case 'y' : analogWrite(yellowPin, brightness); break;
45     case 'g' : analogWrite(greenPin, brightness); break;
46     case 'w' : analogWrite(whitePin, brightness); break;
47
48 }
49
50
51 // analogWrite(ledPin, brightness);
52
53 Serial.print("Intensity set to: ");
54 Serial.println(brightness);
55
56 while (Serial.available() > 0){
57     Serial.read();
58 }
59 // delay(5000);
60 }
61 }

```

Listing A.1: Code for 5 Channel LED control Using Arduino

To change the intensity, give inputs in the serial monitor like w255, r56, o99 etc. The first letter signify the colour to be changed (white, orange etc) and the next number signify the intensity mapped as 0 → 0% and 255 → 100%.

Appendix B



DELHI TECHNOLOGICAL UNIVERSITY
(Formerly Delhi College of Engineering)
Shahbad Daultapur, Main Bawana Road, Delhi-42

PLAGIARISM VERIFICATION

Title of the Dissertation: **‘Design and Development of Cost-effective LED based Solar Simulator’**

Total Pages: 51 Pages

Name of student: Abhay Pratap

Supervisor: Dr. Sarita Baghel

Department: Department of Applied Physics

This is to report that the above dissertation was scanned for similarity detection. Process and outcome is given below:

Software used: Turnitin

Similarity Index: 7%

Total Word Count: 10,062

Date:

Candidate’s Signature

Signature of Supervisor

Abhay Pratap

doc_major_abhay_22may

25-26 dissertation project II

Document Details

Submission ID trn:oid:::27535:140137756	51 Pages 10,062 Words 51,596 Characters
Submission Date May 23, 2026, 6:21 PM GMT+5:30	
Download Date May 27, 2026, 11:59 AM GMT+5:30	
File Name doc_major_abhay_22may.pdf	
File Size 11.2 MB	



Page 1 of 56 - Cover Page

Submission ID trn:oid:::27535:140137756



Page 2 of 56 - Integrity Overview



Submission ID trn:oid:::27535:140137756

7% Overall Similarity

The combined total of all matches, including overlapping sources, for each database.

Filtered from the Report

- ▶ Bibliography
- ▶ Quoted Text
- ▶ Small Matches (less than 10 words)

<p>Match Groups</p> <ul style="list-style-type: none"> ■ 35 Not Cited or Quoted 7% Matches with neither in-text citation nor quotation marks ■ 3 Missing Quotations 0% Matches that are still very similar to source material ■ 0 Missing Citation 0% Matches that have quotation marks, but no in-text citation ■ 0 Cited and Quoted 0% Matches with in-text citation present, but no quotation marks 	<p>Top Sources</p> <ul style="list-style-type: none"> 5%  Internet sources 2%  Publications 6%  Submitted works (Student Papers)
--	---

Integrity Flags
0 Integrity Flags for Review

Our system's algorithms look deeply at a document for any inconsistencies that would set it apart from a normal submission. If we notice something strange, we flag it for you to review.



A Flag is not necessarily an indicator of a problem. However, we'd recommend you focus your attention there for further review.

Figure B.1: Turnitin Similarity Report.

Match Groups

- **35 Not Cited or Quoted 7%**
Matches with neither in-text citation nor quotation marks
- **3 Missing Quotations 0%**
Matches that are still very similar to source material
- **0 Missing Citation 0%**
Matches that have quotation marks, but no in-text citation
- **0 Cited and Quoted 0%**
Matches with in-text citation present, but no quotation marks

Top Sources

- 5%  Internet sources
- 2%  Publications
- 6%  Submitted works (Student Papers)

Top Sources

The sources with the highest number of matches within the submission. Overlapping sources will not be displayed.

1	Student papers	1%
Delhi Technological University on 2026-05-20		
2	Student papers	<1%
Krea University on 2026-05-01		
3	Internet	<1%
link.springer.com		
4	Student papers	<1%
Delhi Technological University on 2026-04-29		
5	Student papers	<1%
Rajiv Gandhi National University of Law on 2026-05-20		
6	Student papers	<1%
University of Nottingham on 2013-05-10		
7	Student papers	<1%
Delhi Technological University on 2026-05-13		
8	Student papers	<1%
Delhi Technological University on 2026-05-16		
9	Publication	<1%
Vedat Esen, Şafak Sağlam, Bülent Oral. "Light sources of solar simulators for phot...		
10	Student papers	<1%
KTH - The Royal Institute of Technology on 2012-09-25		

Abhay Pratap

doc_major_abhay_22may

25-26 dissertation project II

Document Details

<p>Submission ID trn:oid::27535:140137756</p> <p>Submission Date May 23, 2026, 6:21 PM GMT+5:30</p> <p>Download Date May 27, 2026, 12:04 PM GMT+5:30</p> <p>File Name doc_major_abhay_22may.pdf</p> <p>File Size 11.2 MB</p>	<p>51 Pages</p> <p>10,062 Words</p> <p>51,596 Characters</p>
---	---

Page 1 of 53 - Cover Page

Submission ID trn:oid::27535:140137756

Page 2 of 53 - AI Writing Overview

Submission ID trn:oid::27535:140137756

0% detected as AI

The percentage indicates the combined amount of likely AI-generated text as well as likely AI-generated text that was also likely AI-paraphrased.

- 1 AI-generated only 0%**
Likely AI-generated text from a large-language model.
- 0 AI-generated text that was AI-paraphrased 0%**
Likely AI-generated text that was likely revised using an AI-paraphrase tool or word spinner.

Caution: Review required.

It is essential to understand the limitations of AI detection before making decisions about a student's work. We encourage you to learn more about Turnitin's AI detection capabilities before using the tool.

Disclaimer
Our AI writing assessment is designed to help educators identify text that might be prepared by a generative AI tool. Our AI writing assessment may not always be accurate (i.e., our AI models may produce either false positive results or false negative results), so it should not be used as the sole basis for adverse actions against a student. It takes further scrutiny and human judgment in conjunction with an organization's application of its specific academic policies to determine whether any academic misconduct has occurred.

Figure B.2: Turnitin AI Report.