

**Electrophoretic Induction of Native Microbial
Biofilms for Eutrophic Water Remediation and
Prospective Bioelectrochemical Applications**

A Thesis Submitted

In Partial Fulfillment of the Requirements for the Degree of

**MASTER OF SCIENCE in
BIOTECHNOLOGY**

by

SIMRAN KUMARI 24/MSCBIO/20

Under the Supervision of

Prof. JAI GOPAL SHARMA



Department of Biotechnology

DELHI TECHNOLOGICAL UNIVERSITY

**(Formerly Delhi College of Engineering) Shahbad Daultpur, Main Bawana Road,
Delhi-110042. India**

June, 2026

ACKNOWLEDGEMENT

I'd want to thank my supervisor, **Prof. Jai Gopal Sharma**, for allowing me the opportunity to do research and offering crucial guidance throughout the process. His dynamism, vision, genuineness, and motivation have greatly influenced me. He has motivated me to conduct the study and convey my findings as plainly as possible. It was an incredible joy and honor to work and study under his supervision.

I am extremely appreciative for what he has provided me. His insightful suggestions encouraged me to improve my thoughts and elevate my work to the next level. I would like to convey my gratitude to **Prof. Yasha Hasija**, Head of Department, Department of Biotechnology, Delhi Technological University, and all of the faculty members who assisted me with my project. I'd also want to thank Ph.D. scholar **Ms. Aakansha Chauhan** for her continuous help with my practical work. I am really grateful to my friends and family for their guidance and assistance throughout the study process. Finally, I want to thank everyone who has helped me accomplish my research, whether directly or indirectly.

Simran Kumari



DELHI TECHNOLOGICAL UNIVERSITY

(Formerly Delhi College of Engineering)

Shahbad Daultpur, Main Bawana Road, Delhi-42

CANDIDATE'S DECLARATION

I, **SIMRAN KUMARI**, Roll No. **24/MSCBIO/20** hereby certify that the work which is being presented in the thesis entitled “**Electrophoretic Induction of Native Microbial Biofilms for Eutrophic Water Remediation and Prospective Bioelectrochemical Applications**” in partial fulfilment of the requirement for the award of the Degree of Master of Science, submitted by me to the **Department of Biotechnology, Delhi Technological University, Delhi-42** is an authentic record of my own work carried out during the period from January 2026 to June 2026 under the supervision of **Prof. Jai Gopal Sharma**. The matter presented in the thesis has not been submitted by me for the award of any degree of this or any other Institute.

1. My review paper is under revision stage after peer review in SCI/SCI expanded/SSCI/Scopus indexed journal with the following details:

Title of the paper: Converging Native Microbial Consortia in Bioelectrochemical Systems for Eutrophic Water Remediation and Energy Recovery: A Systematic Review”

Name of Authors: Simran Kumari, Lakshay Virmani, J.G. Sharma*

Journal name: Environmental Process

Journal Indexing: Scopus

Status of paper: Under revision

2. My conference paper is accepted in SCI/SCI expanded/SSCI/Scopus indexed journal with the following details:

Title of the paper: Electrophoretic Induction of Native Microbial Biofilms for Enhanced Eutrophication-Oriented Pollutant Degradation and Energy-Relevant Bioelectrochemical Applications

Name of Authors: Simran Kumari, Priyana Parmar, J. G. Sharma

Conference name: International Conference on Biosciences Beyond Boundaries: Healthcare, Bio-Economy & Sustainable Well-being

Conference Indexing: Scopus/WoS

Conference Date: March 14, 2026

Place: Dehradun, India



DELHI TECHNOLOGICAL UNIVERSITY

(Formerly Delhi College of Engineering)

Shahbad Daultapur, Main Bawana Road, Delhi-42

CERTIFICATE BY THE SUPERVISOR

It is certified that **SIMRAN KUMARI**, (24/MSCBIO/20) has carried out her research work presented in this thesis entitled “**Electrophoretic Induction of Native Microbial Biofilms for Eutrophic Water Remediation and Prospective Bioelectrochemical Applications**” for the award of Degree of Masters of Science in Biotechnology and submitted to the Department of Biotechnology, Delhi Technological University, Delhi under my supervision. The thesis embodies results of original work, and studies are carried out by the student herself, and the contents of the thesis do not form the basis for the award of any other degree to the candidate or to anybody else from this or any other University/Institution.

Prof. Yasha Hasija

Head of Department

Department of Biotechnology

Delhi Technological University

Prof. Jai Gopal Sharma

Supervisor

Department of Biotechnology

Delhi Technological University

Date :

Electrophoretic Induction of Native Microbial Biofilms for Eutrophic Water Remediation and Prospective Bioelectrochemical Applications

Simran Kumari

Delhi Technological University, Delhi, India

E-mail: shiak334@gmail.com

ABSTRACT

Microbial biofilms play an important role in pollutant degradation, nutrient cycling, and ecological stabilization within eutrophic aquatic environments. However, controlled and rapid biofilm establishment in engineered remediation systems remains a significant challenge. The present study investigates the electrophoretic induction of native microbial biofilms for eutrophic water remediation and explores its prospective relevance in bioelectrochemical applications. A low-cost electrophoretic chamber was employed to facilitate microbial migration, attachment, and biofilm formation on conductive electrode surfaces using native microbial consortia collected from eutrophic sediment samples. Synthetic eutrophic wastewater was prepared using organic and nutrient-enriched components to simulate polluted aquatic conditions.

The experimental system was operated under a low-intensity electric field and compared with non-electrified control systems to evaluate the influence of electrophoretic conditions on microbial immobilization and pollutant degradation. Biofilm formation was assessed through planktonic colony-forming unit (CFU) enumeration and UV–visible spectrophotometric analysis, while pollutant degradation efficiency was evaluated using a permanganate consumption test as an indicator of oxidizable organic matter reduction.

The electrophoretic system demonstrated enhanced microbial attachment, accelerated biofilm formation, and greater reduction in planktonic microbial populations compared to the control setup, indicating improved microbial immobilization on conductive

surfaces. UV–visible analysis further confirmed increased biofilm-associated biomass under electrified conditions. Additionally, the experimental system exhibited improved degradation of organic pollutants, suggesting the potential applicability of electrophoretically induced microbial biofilms in sustainable eutrophic water remediation.

Although direct electricity generation was not evaluated, the stable formation of biofilms on conductive electrodes highlights the prospective integration of the developed system with bioelectrochemical platforms such as microbial fuel cells for future energy recovery applications. Overall, the study presents a simple, cost-effective, and experimentally accessible approach for enhancing microbial biofilm development and pollutant degradation in eutrophic environments, thereby contributing toward sustainable environmental biotechnology and low-energy wastewater treatment strategies.

Keywords: Electrophoretic chamber, native microbial consortia, microbial biofilm, eutrophic water remediation, bioelectrochemical systems, pollutant degradation, sustainable wastewater treatment.

LIST OF PUBLICATIONS

1. A book chapter entitled “**Mycoremediation and Soil Microbiome Synergies**” was published in the book “Mycoremediation of Xenobiotics” under the series Emerging Paradigms in Pharmaceutical Research, edited by A. Roy, S. Pandit and M. Nandave, published by Springer, Singapore, in 2026. https://doi.org/10.1007/978-981-95-5743-1_7.
2. A book chapter entitled “**The Next Frontier in Bioprocess Engineering: Miniaturized Bioreactors and Their Multisectoral Applications**” was published in the book “Miniaturized Bioreactors: Accelerating Industrial Biotechnology” published by Springer in 2026.
The book is accepted for further proceedings.
3. Presented a paper entitled “**Electrophoretic Induction of Native Microbial Biofilms for Enhanced Eutrophication-Oriented Pollutant Degradation and Energy-Relevant Bioelectrochemical Applications**” at the International Conference on Biosciences Beyond Boundaries: Healthcare, Bio-Economy & Sustainable Well-being organized jointly by Institute of Eminence Science and Research, IESR in association with Sardar Bhagwan Singh University, Balawala, held in Dehradun, India on 14 March.
The conference paper is accepted for further proceedings.
4. A review paper entitled “**Mannan-Rich Fractions in Poultry Nutrition: Sustainable and Defensive Strategy against Antimicrobial Resistance**” has been accepted for publication in “Recent Trends in Infectious Diseases.”
5. A review paper entitled “**Converging Native Microbial Consortia in Bioelectrochemical Systems for Eutrophic Water Remediation and Energy Recovery: A Systematic Review**” is currently under revision stage after peer review for publication in scopus indexed journal “Environmental Processes”.

LIST OF FIGURES

Figure	Description
Figure 2.1	Schematic diagram of dual-chamber Microbial Fuel Cell
Figure 2.2	Schematic diagram of Microbial Electrolysis Cell
Figure 3.1	Satpula Lake, New Delhi, showing eutrophication
Figure 3.2	Electrophoretic chamber connected to DC power supply
Figure 3.3	Experimental setup used for KMnO_4 titration analysis
Figure 4.1	Cloudy accumulation observed in the electrophoretic chamber during incubation.
Figure 4.2	Temporal variation in microbial colony formation observed during CFU analysis
Figure 4.3	KMnO_4 titration endpoint of experimental samples.
Figure 4.4	Crystal violet retention observed within the electrophoretic chamber after incubation.
Figure 4.5	UV-Visible absorbance measurement of crystal violet extract at 570 nm
Figure 4.6	Microscopic observation of aggregated structures at 10 \times magnification.

LIST OF TABLES

TABLE	Description
Table 3.1	Composition of Synthetic Nutrient Media
Table 3.2	Operational Parameters maintained during electrophoretic treatment
Table 3.3	Composition of chemicals for KMnO ₄ analysis
Table 3.4	Reagents used for Crystal Violet Assay
Table 4.1	Comparative analysis of microbial population (CFU/ml) in control and electrophoretic systems during incubation
Table 4.2	Variation in KMnO ₄ consumption during electrically stimulated incubation
Table 4.3	Absorbance values obtained after crystal violet extraction at 570 nm

LIST OF SYMBOLS, ABBREVIATIONS

°C: Degree Celsius

V: Voltage

mA: milli ampere

N: Nitrogen

K: Phosphorous

BESs: Bioelectrochemical Systems

MFC: Microbial Fuel Cell

MEC: Microbial Electrolysis Cell

EF: Electric Field

UV-Vis: Ultraviolet (UV)-visible spectroscopy

TABLE OF CONTENTS

Acknowledgment	ii
Candidate's declaration	iii-iv
Certificate by the Supervisor	v
Abstract	vi-vii
List of Publications	viii
List of Figures	ix
List of Tables	x
List of Symbols and Abbreviations	xi
Table of Contents	xii-xv

CHAPTER 1: INTRODUCTION	
1.1 Background of Eutrophication and Aquatic Environment	1-2
1.2 Native Microbial Consortia in Environmental Remediation	2-3
1.3 Microbial Biofilms and Environmental Remediation	3
1.4 Bioelectrochemical Systems and Their Environmental Relevance	4
1.5 Electrical Stimulation and Microbial Behaviour	4-5
1.6 Problem Statement	5-6
1.7 Rationale of Present Study	6
1.8 Aim of Study	6-7
1.9 Objectives of the Study	7
1.10 Hypothesis of the Study	7
CHAPTER 2: LITERATURE REVIEW	
2.1 Overview of Eutrophication and its Environmental Impact	8
2.2 Native Microbial Consortia and Natural Nutrient Cycling	9-10
2.3 Bioelectrochemical Systems (BESs)	10-13
2.4 Biofilm Formation and Microbial Aggregation	13-14
2.5 Applications of BESs in Eutrophic Water Remediation and Resource Recovery	14-20
2.6 Challenges and Limitations of BESs	20-21
2.7 Identified Future Perspective of BESs in Environmental Remediation	21-22
2.8 Research Gap and Rationale of Present study	22-23

CHAPTER 3: MATERIALS AND METHODS	
3.1 Materials Required	24-26
3.2 Sample Collection	26
3.3 Preparation of Native Microbial Inoculum	26-27
3.4 Biofilm Preparation of Synthetic Nutrient Media	27
3.5 Preparation of Nutrient Agar Plates	27-28
3.6 Experimental Setup	28-29
3.7 Colony Forming Unit Analysis	30
3.8 Potassium Permanganate (KMnO ₄) Consumption Analysis	30-31
3.9 Crystal Violet Assay and UV-Visible Spectrophotometric Analysis	31-33
3.10 Microscopic Observation	34
3.11 Data Recording and Statistical Analysis	34
CHAPTER 4: RESULT AND DISCUSSION	
4.1 Formation of Biofilm in Electrophoretic Chamber	35-36
4.2 Colony Forming Unit Analysis	37-38
4.3 Potassium Permanganate (KMnO ₄) Consumption Analysis	38-40
4.4 Crystal Violet Assay and UV-Visible Spectrophotometric Analysis	40-42
4.5 Microscopic Analysis	42-43
4.6 Discussion	43-44
4.7 Conclusion	44-45

CHAPTER 5: REFERENCES	46-55
Plagiarism Report	56-57
List of Publication with Acceptance letters and Certificates	60-61

CHAPTER 1

INTRODUCTION

1.1 Background of Eutrophication and Aquatic Pollution

Rapid industrialization, urbanization, intensive agricultural practices, and increasing anthropogenic activities have significantly contributed to the deterioration of aquatic ecosystems worldwide (Glibert, 2020). One of the major environmental problems associated with aquatic pollution is eutrophication, a process characterized by excessive enrichment of water bodies with nutrients such as nitrogen and phosphorus (Paerl et al., 2016). These nutrients mainly originate from agricultural runoff, domestic sewage discharge, industrial effluents, aquaculture activities, and improper waste disposal practices (Correll, 1998). Excess nutrient accumulation stimulates uncontrolled growth of algae and microorganisms, resulting in algal blooms, oxygen depletion, ecological imbalance, and deterioration of water quality (Jenny et al., 2020).

Eutrophic water bodies often exhibit high biological oxygen demand (BOD), elevated organic load, reduced dissolved oxygen concentration, unpleasant odor, and loss of aquatic biodiversity (Huisman et al., 2018). During eutrophication, excessive algal biomass eventually undergoes decomposition by microorganisms, leading to rapid oxygen consumption and formation of hypoxic or anoxic conditions that adversely affect aquatic organisms and ecosystem functioning (Falkowski et al., 2008). In addition, some cyanobacterial blooms produce harmful cyanotoxins that threaten both environmental and public health (Huisman et al., 2018).

Conventional remediation methods for eutrophic water treatment commonly involve physical and chemical approaches such as mechanical aeration, chemical oxidation, coagulation, and activated sludge systems (Lavanya et al., 2023). Although these methods are effective in reducing pollutant load, they are often energy-intensive, expensive, and

difficult to implement in decentralized or low-resource settings (Nidheesh et al., 2022). Moreover, chemical treatment processes may generate secondary pollutants and require continuous operational maintenance. Therefore, there is an increasing need for sustainable, biologically driven, and low-energy remediation technologies for aquatic ecosystem restoration (Nguyen et al., 2024).

1.2 Native Microbial Consortia in Environmental Remediation

Native microbial consortia are indigenous mixed microbial communities naturally present in aquatic ecosystems, sediments, and wastewater environments. These communities act as important biological catalysts in environmental remediation due to their metabolic diversity, ecological adaptability, and ability to survive under fluctuating environmental conditions (Falkowski et al., 2008). Unlike pure microbial cultures, native consortia possess high functional redundancy and cooperative metabolic interactions, which improve pollutant degradation efficiency and enhance system stability under stressed environmental conditions (Nguyen et al., 2024).

In bioelectrochemical systems (BESs), native microbial consortia facilitate degradation of organic pollutants, nutrient transformation, and extracellular electron transfer. Fermentative microorganisms such as *Clostridium* and *Bacteroides* degrade complex organic matter into simpler intermediates, which are subsequently utilized by electroactive bacteria such as *Geobacter* and *Shewanella* for electron transfer and bioelectricity generation (Lovley et al., 2017; Chong et al., 2025). These microbial interactions contribute toward reduction of chemical oxygen demand (COD), nutrient removal, and pollutant remediation within wastewater systems.

Native microbial consortia also support nitrogen removal through bioelectrochemical denitrification mediated by electroactive denitrifiers such as *Pseudomonas* and *Azocarcus*, while phosphorus recovery may occur through electrochemically induced struvite precipitation under alkaline cathodic conditions (Zhou et al., 2023; Cerrillo et al., 2023). Additionally, these microbial communities participate in heavy metal sequestration through biosorption, bioaccumulation, and reductive transformation processes, thereby

improving remediation efficiency in mixed-contaminant environments (Liang et al., 2025).

Due to their environmental adaptability and multifunctional remediation capabilities, native microbial consortia are increasingly being explored for sustainable eutrophic water treatment and development of advanced BES-based remediation technologies.

1.3 Microbial Biofilms and Environment Remediation

Microorganisms play a fundamental role in nutrient cycling, organic matter degradation, and maintenance of ecological stability in aquatic ecosystems (Prosser et al., 2007). In natural environments, microbial communities predominantly exist as biofilms, which are structured microbial assemblages attached to surfaces and embedded within extracellular polymeric substances (EPS) (Angelaalincy et al. 2018; Patil et al. 2012). Biofilms provide several advantages to microorganisms, including enhanced metabolic cooperation, environmental stress tolerance, substrate utilization efficiency, and long-term ecological stability compared to planktonic cells (Das et al., 2021).

Microbial biofilms have gained considerable attention in environmental biotechnology because of their ability to degrade pollutants, immobilize contaminants, and sustain microbial activity under adverse environmental conditions (Logan et al., 2012). Biofilm-mediated processes are widely explored for wastewater treatment, nutrient removal, biodegradation of organic pollutants, and heavy metal remediation (Sharma et al., 2024). In engineered treatment systems, biofilms attached to conductive or inert surfaces can facilitate continuous microbial activity while improving system stability and pollutant degradation efficiency (Li et al., 2024).

Despite their environmental importance, controlled and rapid biofilm establishment remains a major challenge in laboratory-scale and engineered remediation systems (Tao et al., 2023). Natural biofilm formation is often slow and depends on several factors such as nutrient availability, surface characteristics, hydrodynamic conditions, and microbial interactions (Cerrillo et al., 2023). Therefore, innovative approaches that promote rapid

microbial attachment and biofilm development are essential for improving sustainable bioremediation technologies.

1.4 Bioelectrochemical Systems and Their Environmental Relevance

Recent advances in environmental biotechnology have highlighted the significance of bioelectrochemical systems (BESs) for simultaneous wastewater treatment and renewable energy recovery (Logan et al., 2012). BESs integrate microbiology and electrochemistry to facilitate electron transfer between microorganisms and conductive materials (Bazina et al., 2023). Common examples of BESs include microbial fuel cells (MFCs), microbial electrolysis cells (MECs), and sediment microbial fuel cells (Gómez et al., 2025).

In these systems, electroactive microorganisms oxidize organic substrates and transfer electrons to conductive electrodes through extracellular electron transfer mechanisms (Lovley, 2006). This process enables pollutant degradation while simultaneously generating electrical current or other valuable products such as hydrogen and methane (Gude, 2018). BES technologies are increasingly considered sustainable alternatives for low-energy wastewater treatment and environmental remediation (Das et al., 2021).

The efficiency of BESs largely depends on stable microbial attachment and biofilm formation on electrode surfaces (Tao et al., 2023). However, achieving rapid and stable colonization of conductive surfaces using native microbial communities remains a major technical limitation (Nguyen et al., 2024). Native microbial consortia obtained from eutrophic environments possess ecological adaptability, metabolic diversity, and stress tolerance, making them suitable candidates for sustainable remediation systems (Shade, 2023). Enhancing the attachment and organization of such native microbial communities on conductive surfaces may significantly improve pollutant degradation efficiency and future bioelectrochemical performance (Lavanya et al., 2023).

1.5 Electrical Stimulation and Microbial Behaviour

The Microbial cells generally possess negatively charged cell surfaces due to the presence of ionizable functional groups such as carboxyl and phosphate groups (Bos et al., 1999).

Under the influence of an electric field, microbial cells can migrate toward oppositely charged conductive surfaces through electrophoretic movement. This phenomenon provides an opportunity to accelerate microbial attachment and promote biofilm initiation on electrode surfaces.

Application of low-intensity electric fields has recently gained attention for influencing microbial migration, biofilm development, and extracellular electron transfer behavior (Liu et al., 2018). Electrophoretic systems may facilitate controlled microbial immobilization while overcoming the limitations associated with slow natural biofilm formation (Yu et al., 2024). Such electrically assisted microbial systems can serve as cost-effective and experimentally accessible platforms for studying biofilm dynamics and sustainable wastewater remediation processes.

In addition to pollutant degradation, stable biofilms formed on conductive electrodes may possess future applicability in bioelectrochemical systems for renewable energy recovery (Logan et al., 2012). Therefore, integration of electrophoretic biofilm induction with native microbial consortia represents a promising interdisciplinary strategy in environmental biotechnology.

1.6 Problem Statement

Eutrophication and wastewater pollution continue to pose serious environmental challenges due to excessive nutrient loading, organic matter accumulation, and ecological imbalance in aquatic ecosystems. Conventional remediation approaches are often energy-intensive, costly, and may not efficiently support simultaneous pollutant removal and resource recovery. Although bioelectrochemical systems (BESs) have emerged as promising sustainable technologies for wastewater treatment and nutrient remediation, limited information is available regarding the behavior of native microbial consortia under prolonged electrically stimulated conditions.

Most existing studies primarily focus on reactor performance, electricity generation, and pollutant removal efficiency, whereas comparatively less attention has been given to microbial redistribution, aggregation behavior, and preliminary surface-associated growth within simple electrophoretic environments. Furthermore, the interaction between native

eutrophic microbial communities and electrical stimulation remains insufficiently understood.

Therefore, there is a need to investigate how prolonged electrical exposure influences native microbial populations, microbial colony dynamics, oxidizable organic matter, and possible preliminary biofilm-associated aggregation under electrophoretic conditions. Understanding these responses may contribute toward future development of sustainable bioelectrochemical remediation technologies for eutrophic water treatment.

1.7 Rationale of Present Study

Eutrophication caused by excessive nutrient accumulation has become a major environmental concern affecting aquatic ecosystems worldwide. Conventional wastewater treatment approaches often require high energy input and may not efficiently support simultaneous pollutant removal and resource recovery. In recent years, bioelectrochemical systems (BESs) have emerged as promising sustainable technologies for nutrient remediation, wastewater treatment, and bioenergy generation through microbial-electrode interactions (Nidheesh et al., 2022).

Native microbial consortia present within eutrophic water bodies possess significant metabolic diversity and environmental adaptability, making them suitable candidates for bioelectrochemical remediation applications. However, limited information is available regarding the behavior of native microbial communities under prolonged electrically stimulated conditions, particularly with respect to microbial redistribution, aggregation, and preliminary biofilm-associated growth within electrophoretic environments.

Understanding microbial responses to electrical stimulation is important because microbial attachment and biofilm formation strongly influence extracellular electron transfer, pollutant degradation, and operational stability in BESs. Therefore, the present study was designed to investigate the effect of prolonged electrical stimulation on native microbial consortia obtained from eutrophic water samples using an electrophoretic chamber system. The study focused on evaluating microbial colony dynamics, crystal

violet retention, oxidizable organic content, and possible surface-associated microbial aggregation under electrically stimulated conditions.

1.8 Aim of the Study

To investigate the effect of prolonged electrical stimulation on native microbial consortia obtained from eutrophic water samples using an electrophoretic chamber system, with emphasis on microbial colony dynamics, crystal violet retention, oxidizable organic content, and possible preliminary biofilm-associated microbial aggregation under electrically stimulated conditions.

1.9 Objectives of the Study

The present study was conducted with the following objectives:

- To investigate the effect of prolonged electrical stimulation on native microbial consortia obtained from eutrophic water samples.
- To evaluate changes in planktonic microbial population under electrically stimulated conditions using colony-forming unit (CFU) analysis.
- To assess possible surface-associated microbial aggregation through crystal violet staining and UV-Visible spectrophotometric analysis.
- To analyze variations in oxidizable organic constituents and microbial activity using potassium permanganate (KMnO₄) analysis.
- To observe microscopic changes and aggregated structures formed within the electrophoretic chamber during prolonged incubation.

1.10 Hypothesis of the Study

Prolonged electrical stimulation may influence the behavior of native microbial consortia obtained from eutrophic water samples by altering microbial distribution, reducing free-floating planktonic populations, and promoting possible preliminary surface-associated microbial aggregation within an electrophoretic chamber system

CHAPTER 2

REVIEW OF LITERATURE

2.1 Overview of Eutrophication and its Environmental Impact

Eutrophic water bodies emerge when the concentrations of environmentally favorable elements, such as nitrogen and phosphorus, exceed the natural assimilation capacity, commonly due to fertilizer runoff, domestic sewage, aquaculture, and industrial discharge (Glibert 2020). This nutrient surplus stimulates excessive phytoplankton and cyanobacterial growth, which further leads to the generation of harmful algal blooms (HABs) that reduce light penetration and alter food-web dynamics (Paerl et al. 2016). Consequently bloom biomass decays, microbial respiration increases, and there is rapid consumption of dissolved oxygen, promoting hypoxia or anoxia, leading to fish mortality and loss of benthic fauna (Jenny et al. 2020). Many bloom-forming cyanobacteria also produce cyanotoxins, such as microcystins and anatoxin-a, threatening the safety of drinking water and human health (Huisman et al. 2018). Thus, eutrophic systems are defined by nutrient overload, oxygen depletion, and ecological destabilization, which reinforces the need for sustainable biological remediation frameworks.

Recent studies have therefore emphasized the development of sustainable and low-energy remediation technologies capable of simultaneously treating wastewater and recovering valuable resources (Nguyen et al., 2024). Among these emerging approaches, bioelectrochemical systems (BESs) have gained significant attention due to their ability to integrate microbial metabolism with electrochemical processes for pollutant degradation, nutrient removal, and renewable energy generation (Nidheesh et al., 2022). The utilization of native microbial consortia within BES platforms further enhances environmental adaptability and remediation efficiency under eutrophic conditions.

2.2 Native Microbial Consortia and Natural Nutrient Cycling

Native microbial consortia are naturally occurring mixed microbial communities present within aquatic and eutrophic environments. These microbial populations consist of diverse groups of bacteria, fungi, algae, and other microorganisms that interact synergistically to maintain ecological balance and nutrient cycling within aquatic ecosystems (Zhang et al., 2021). They play a foundational role in regulating nutrient fluxes in eutrophic ecosystems. Autochthonous nitrifiers, denitrifiers, methanotrophs, and phosphate-accumulating organisms drive nitrogen removal and phosphorus sequestration which influences whether aquatic ecosystems undergo recovery or persistent eutrophication (Falkowski et al. 2008). For example, ammonia-oxidizing bacteria facilitate the conversion of NH_4^+ to NO_3^- , whereas denitrifying organisms subsequently transform NO_3^- into N_2 gas, thereby reducing the bioavailability of nitrogen in the environment. Similarly, microbial assimilation into biomass can temporarily immobilize phosphate during active growth phases (Correll 1998). These metabolic interactions are self-organizing and adaptive, forming a critical basis for biological restoration strategies in eutrophic waters.

2.2.1 Autochthonous Microbe VS Laboratory-Engineered Strains

Although some engineered microbial strains exhibit high catalytic performance in controlled reactors, they often fail to persist in natural waters due to competition, predation, salinity shifts, and light-temperature fluctuations (Curtis et al. 2004). In contrast, native microbial consortia are pre-adapted to the physicochemical characteristics of their environment and maintain complex syntrophic networks, such as supporting nutrient transformation and pollutant degradation (Prosser et al. 2007). Recent ecological studies have also shown that microbial community resilience increases with local biodiversity and metabolic redundancy, enabling consistent function under environmental stress (Shade 2023). Therefore, indigenous microbial assemblages can offer superior ecological compatibility with long-term stability and reduced inoculation costs compared to lab-modified strains.

2.2.2 Native Microbial Consortia as Biocatalyst in Bioelectrochemical System (BESs)

The integration of native microbial consortia with bioelectrochemical systems (BESs), including microbial fuel cells (MFCs) and microbial electrochemical cell, supports the dual objectives of eutrophication control and renewable energy recovery (Logan et al. 2012). Electrogenic bacteria colonize the anode and oxidize organic pollutants, sending electrons through an external circuit to generate low-voltage electricity while simultaneously reducing the chemical oxygen demand (COD) and nutrient loads (Sharma et al. 2024; Li et al. 2024). Recent Indian field implementations using local phototrophic-rhizosphere consortia demonstrated ~60–95% nitrate and phosphate reduction alongside sustained power output, validating in situ ecological alignment (Kumar et al. 2023). Thus, the integration of indigenous microbiomes with BES platforms creates a self-sustaining, low-energy, field-deployable remediation system suitable for eutrophic aquatic environment.

Key Microbial Groups and their Synergistic Behavior

- *Geobacter spp.*, commonly found in river sediments and wetlands, are among the most efficient electrogenic organisms owing to their dense multilayer biofilm architecture and conductive pili (Ueki et al. 2018).
- *Shewanella spp.*, thrive in fluctuating redox conditions, which helps them enable flexible EET strategies and support bioelectrochemical activity even under changing oxygen regimes.
- Cyanobacteria, such as *Synechococcus* and *Anabaena*, contribute to BES systems through oxygen evolution at the cathode, which generally allows photosynthetically assisted MFCs, where light drives electron acceptor regeneration (Saratale et al. 2022).
- Anaerobic syntrophic bacteria, methanogens, and fermenters also play crucial roles in breaking down complex organic matter into smaller metabolites so that core electrogens can be oxidized.

2.3 Bioelectrochemical Systems (BESs)

Bioelectrochemical systems (BES) represent a transformative approach in environmental biotechnology that couples biological redox reactions with electrode-mediated electron transfer to enable the conversion of chemical energy from organic matter into electrical energy or valuable bioproducts (Gómez et al. 2025). Bioelectrochemical systems (BES) fundamentally integrate microbial metabolism with an external electrical circuit. This integration facilitates the capture of electrons generated during substrate oxidation, which can then be harvested as electrical current or redirected towards the synthesis of high-value products. Consequently, BES are positioned at the intersection of eutrophic wastewater treatment and sustainable energy recovery (Bazina et al., 2023).

The two most prominent configurations of BESs are Microbial Fuel Cells (MFCs) and Microbial Electrolysis cells (MECs), as illustrated in Figure 2.1 and 2.2.

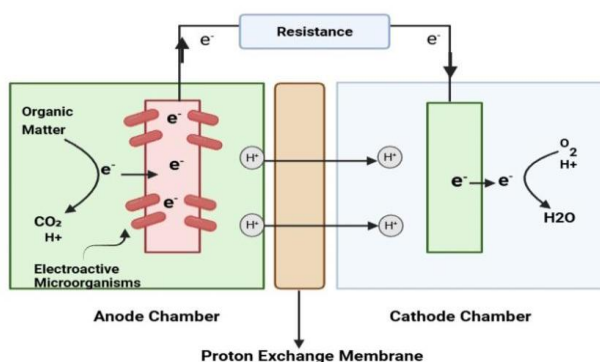

Fig 2.1: Schematic diagram of dual-chamber Microbial Fuel Cell

In Microbial Fuel Cells (MFCs), the oxidation of organic substrates at the anode and the reduction of terminal electron acceptors (typically oxygen) at the cathode occur spontaneously ($\Delta G < 0$) (Gude 2018).

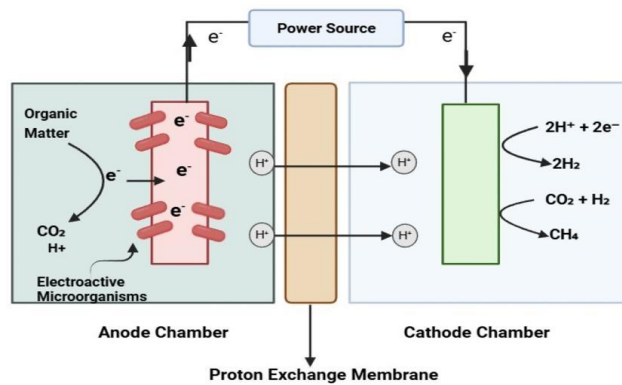

Fig 2.2: Schematic diagram of microbial electrolysis cell set up

In contrast, Microbial Electrolysis Cells (MECs) operate under non-spontaneous thermodynamic conditions ($\Delta G > 0$) and require the application of a small external voltage, typically in the range of 0.2-1.0 V, to drive energetically unfavourable cathodic reactions, such as hydrogen or methane production (Gude 2018).

2.3.1 Anodic Microbial Oxidation and Bioelectrocatalysis

The anode serves as the primary site of microbial catalysis in BES, where electroactive microorganisms oxidize organic substrates under anaerobic conditions and transfer the released electrons to a solid electrode. These microorganisms, commonly referred to as electroactive bacteria (EAB) or exoelectrogens, utilize the anode as a terminal electron acceptor in place of soluble acceptors such as oxygen or nitrate. During anodic metabolism, complex organic matter present in wastewater or eutrophic systems is progressively degraded through microbial respiratory pathways, releasing electrons, protons, and carbon dioxide (Tao et al. 2023; Cerrillo et al. 2023).

2.3.2 Extracellular Electron Transfer (EET) Mechanisms

The defining mechanistic feature of BES is the ability of microorganisms to transport electrons, which are generated intracellularly to extracellular solid electrodes by a process known as extracellular electron transfer (EET). This bidirectional process enables

microbes to bridge the spatial gap between metabolic redox reactions and insoluble solid electron acceptors and occurs through multiple coexisting pathways (Tao et al. 2023).

- **Direct electron transfer:** It generally involves physical contact between microbial cells and the electrode surface, allowing electrons to flow without the need for soluble mediators. This process is primarily facilitated by outer membrane c-type cytochromes, which function as electrochemical gates, enabling electron transport across the cell envelope or by using nanowires or pili, which extend beyond the cell surface and establish long-range electrical connectivity (Hazzan et al. 2023; Jiang et al. 2023; Agudelo-Escobar et al. 2022; Angelaalincy et al. 2018).
- **Mediated electron transfer:** In this electron are transported between microbial cells and electrodes via diffusible redox-active molecules known as electron shuttles. These mediators may be endogenously produced by microorganisms (flavins, quinones and phenazines) or externally supplied to the system (Tian et al. 2019; Agudelo-Escobar et al. 2022; Tao et al. 2023; Hazzan et al. 2023).
- **Interspecies electron transfer:** In some complex microbial communities, electron transfer frequently extends beyond individual cell electrode interactions through interspecies electron transfer (IET). This process may occur via direct interspecies electron transfer (DIET), which is mediated by conductive biological structures or mineral phases, or mediated interspecies electron transfer (MIET) involving metabolites such as hydrogen or formate (Jiang et al. 2023; Guo et al. 2023).

2.3.3 Cathodic Process and Product Formation

At the cathode, electrons delivered through the external circuit are consumed in reduction reactions that complete the electrochemical loop (Das et al. 2021). In MFCs, the most common cathodic reaction is the oxygen reduction reaction (ORR), which produces water and enables continuous electricity generation. Cathodic performance often represents a rate-limiting step owing to the slower reaction kinetics and limitations of the catalyst (Ojha et al. 2024; Chong et al. 2025).

In MECs and related configurations, cathodes are maintained under anaerobic conditions to facilitate electrohydrogenesis, electromethanogenesis, or the synthesis of other reduced

compounds (Ahmad et al. 2022). These systems enable the recovery of energy-rich products from wastewater-derived electrons, extending the functionality of BESs beyond power generation to chemical production.

2.4 Biofilm Formation and Microbial Aggregation

Biofilm formation is an important phenomenon in bioelectrochemical systems (BESs), where microorganisms attach to conductive surfaces and develop structured microbial communities embedded within extracellular polymeric substances (EPS). These biofilms enhance microbial stability, facilitate extracellular electron transfer, and improve long-term operational efficiency within BES platforms (Garbini et al., 2023; Angelaalincy et al. 2018; Patil et al. 2012).

Biofilm development generally occurs through sequential stages including initial microbial attachment, irreversible adhesion, microcolony formation, maturation, and eventual dispersal. During this process, microorganisms secrete extracellular polymeric substances composed primarily of polysaccharides, proteins, lipids, and extracellular DNA, which provide structural stability and protection against environmental stress.

In BESs, electroactive microorganisms such as *Geobacter spp.* and *Shewanella spp.* form electrochemically active biofilms on electrode surfaces that facilitate efficient electron transfer and substrate oxidation (Sun et al. 2016; Conners et al. 2022). Biofilm-associated microbial communities exhibit improved resistance against pH fluctuations, toxic compounds, oxidative stress, and nutrient limitations compared to free-floating planktonic cells (Nguyen et al., 2024).

The efficiency of biofilm formation is influenced by several factors including electrode material, surface roughness, nutrient availability, microbial community composition, pH, conductivity, and applied electrical conditions. Electrical stimulation may alter microbial adhesion behavior, promote localized aggregation, and influence extracellular polymeric substance production within microbial systems (Angelaalincy et al. 2018; Das et al. 2021; Ojha et al. 2024).

In eutrophic and wastewater-associated environments, native microbial consortia demonstrate strong adaptability toward biofilm-associated growth due to their metabolic diversity and cooperative interactions. Such biofilm-associated microbial aggregation enhances pollutant degradation, nutrient cycling, and long-term stability of BES platforms (Zhao et al. 2025; Szakács et al. 2025; Jiang et al. 2023).

Therefore, microbial biofilm formation represents a critical factor governing electron transfer efficiency, microbial survival, and overall remediation performance in bioelectrochemical systems.

2.5 Applications of BESs in Eutrophic Water Remediation and Resource Recovery

The transition from conventional linear wastewater treatment approaches toward circular resource recovery systems has become an important objective in sustainable environmental engineering. Bioelectrochemical systems (BESs) have emerged as multifunctional remediation platforms capable of simultaneously removing pollutants while recovering valuable resources from eutrophic waters. By utilizing the chemical energy stored within organic matter and excess nutrients, BESs transform wastewater into reusable resource streams, thereby supporting integrated remediation and circular bioeconomy principles.

2.5.1 Nutrient Removal and Cycling Mediated by Native Microbial Consortia

Nutrient enrichment, particularly excessive nitrogen and phosphorus accumulation, represents the major driving force behind eutrophication in aquatic ecosystems. Within BESs, electroactive microbial consortia facilitate simultaneous nutrient transformation, removal, and recovery through coupled biological and electrochemical pathways.

Nitrogen remediation in BESs primarily occurs through bioelectrochemical denitrification processes. Nitrate and nitrite function as terminal electron acceptors at the cathode, where denitrifying exoelectrogenic microorganisms such as *Azonexus* and *Pseudomonas* directly receive electrons from conductive electrodes and reduce nitrate into dinitrogen gas N_2 (Zhou et al., 2023). Unlike conventional denitrification systems,

this process reduces dependence on external organic carbon supplementation (Yao et al., 2025). Simultaneously, ammonium ions migrate toward the cathode through cation-selective membranes due to electrochemical charge imbalance. Elevated cathodic pH conditions facilitate conversion of ammonium into gaseous ammonia, enabling ammonia stripping and recovery as ammonium salts suitable for fertilizer applications (Cerrillo et al., 2023). In algae-assisted BES systems, photosynthetic microalgae additionally assimilate inorganic nitrogen into biomass, further enhancing nutrient recovery efficiency (Guadalupe et al., 2024).

Phosphorus remediation within BESs involves electrochemically induced phosphate precipitation and sediment stabilization mechanisms. Localized alkaline conditions near the cathode favor precipitation of phosphate in the presence of ammonium and magnesium ions, resulting in formation of struvite, an agriculturally valuable slow-release fertilizer (Barbosa et al., 2019; Cerrillo et al., 2023).

In sediment microbial fuel cells (SMFCs), maintenance of elevated redox potential suppresses reductive dissolution of iron-bound phosphorus and limits phosphorus re-release into overlying water bodies, thereby supporting long-term eutrophication mitigation (Perera et al., 2023).

2.5.2 Sulphur and Heavy Metal Transformation in BESs

Apart from nutrient remediation, BESs also facilitates sulfur transformation and heavy metal removal in wastewater-impacted environments. Sulfate-reducing microorganisms such as *Desulfovibrio spp.* utilize cathodic electrons to reduce sulfate compounds, whereas sulfur-oxidizing bacteria such as *Sulfurimonas* and *Pseudomonas* mediate sulfide oxidation and detoxification processes (Das et al., 2021; Li et al., 2024). Heavy metal ions present in eutrophic wastewater may undergo reductive transformation into less toxic or insoluble forms at the cathode, thereby improving overall remediation efficiency (Tao et al., 2023).

2.5.3 Simultaneous Bioelectricity Production: Waste-to-Watts Concept

Bioelectrochemical systems (BESs), particularly microbial fuel cells (MFCs) and related configurations, uniquely integrates the waste valorization and energy recovery by harnessing microbial metabolism to convert chemical energy in pollutants into electrical energy (Chong et al. 2025; Ojha et al. 2024). Biodegradable organic substrates present in eutrophic waters and waste streams serves both as the remediation target and the energy source, thereby transforming wastewater treatment from an energy-intensive process into one capable of particularly offsetting energy demand through bioelectricity recovery (Bhagat et al. 2025; Shajid et al. 2025). The mechanism underpinning the phrase “waste-to-watts” concept is the coupling of microbial extracellular electron transfer with electrochemical circuit (Jiang et al. 2023; Ojha et al. 2024). Electroactive microorganisms oxidize the organic matter at the anode, further liberating electrons that flow through an external circuit toward the cathode, producing a measurable current (Chong et al. 2025; Yaqoob et al. 2020). This current obtained is not typically harvested as grid electricity; rather, it serves as an energy offset that can reduce or replace auxiliary power needs such as low-energy sensors, control electronics, or internal mixing, thereby lowers the overall net energy footprint of wastewater treatment (Chong et al. 2025).

Importantly, BES energy recovery helps mitigate the significant energy demand associated with mechanical aeration and pumping in conventional treatment systems (Gude 2018). By enabling anaerobic oxidation and electron capture without the use of external aeration, BES reduce operational energy inputs and align treatment with circular bioeconomy goals (Gude 2018; Shajid et al. 2025). Recent reviews highlight that, absolute power densities and innovations in microbial ecology, electrode materials, and reactor design are also enhancing energy recovery in real wastewater contexts, bridging the gap between laboratory demonstrations and practical applications (Liang et al. 2025; Gómez et al. 2025). Native mixed microbial consortia play a central role in stabilizing bioelectricity generation, especially under complex wastewater conditions (Esfandyari et al. 2024).

2.5.4 Chemical Products and Resource Recovery During BES Treatment

In addition to nutrient removal, bioelectrochemical systems (BESs) that treat eutrophied waters act as integrated bio-conversion platforms, enabling the formation of multiple value-added chemical products through coupled microbial metabolism and electrochemical reactions.

During the anodic degradation of organic matter and algal biomass, fermentative bacteria such as *Clostridium*, *Bacteroides*, and *Arcobacter* convert complex substrates into volatile fatty acids (VFAs) such as acetate, propionate, and butyrate through acidogenic pathways. In stable BES operation, these VFAs function as transient metabolic intermediates, which are rapidly oxidized by exoelectrogenic bacteria. This metabolic coupling links organic carbon mineralization to the current generation and prevents VFA accumulation (Lovley 2017; Das et al. 2021; Jatoi et al. 2026). Beyond their role as electron donors, VFAs can be selectively redirected toward secondary bioproduct formation, including the synthesis of polyhydroxyalkanoates (PHAs) and biodegradable bioplastics through mixed microbial consortia under controlled nutrient-limiting conditions. In microbial electrolysis configurations, cathodic reactions enable the generation of hydrogen gas (H_2) as a clean energy carrier. Additionally, BESs operated under oxygen-limited cathodic conditions can produce hydrogen peroxide (H_2O_2) via the two-electron oxygen reduction reaction, which is a valuable green oxidant for disinfection, advanced oxidation processes, and chemical manufacturing (Das et al. 2020a).

Collectively, these mechanisms highlight BESs as multifunctional systems capable of converting eutrophied water into streams of fertilizer precursors, energy carriers, green oxidants, and biochemical intermediates, reinforcing their relevance for circular bioeconomy-oriented water remediation (Unuofin et al. 2024).

2.5.5 Bioremediation of Algal Biomass Using BESs

Bioremediation utilizing algal biomass within bioelectrochemical systems (BES) primarily functions through two main mechanisms: the employment of algal biomass as a fuel source at the anode and the use of living photosynthetic microorganisms at the cathode for nutrient remediation (Luo et al. 2017). Together, these pathways enable the

integration of eutrophication remediation with bioelectrochemical energy recovery within a single system framework.

In the anodic compartment, harvested algal and cyanobacterial biomass can function as organic feedstocks. Following hydrolysis and fermentation, exoelectrogenic bacteria oxidize algal-derived intermediates, transferring electrons to the anode, and enabling the production of bioelectricity (Pandya et al. 2024). Various algal taxa, *Chlorella vulgaris*, *Ulva lactuca*, and *Microcystis aeruginosa*, have been explored as substrates, with differences in degradability attributed to variations in cell wall composition and biochemical structure (Patel et al. 2021a; Wang et al. 2015; Luo et al. 2017). To enhance anodic utilization, pretreatment strategies such as anaerobic digestion, thermal treatment, and microwave-assisted disruption have been applied to improve microbial accessibility to intracellular organic matter (Luo et al. 2017).

Conversely, photosynthetic microorganisms play a functional role in nutrient remediation and oxygen supply in the cathodic compartment. In photosynthetically assisted BES, algae generate dissolved oxygen through photosynthesis, serving as a sustainable electron acceptor and reducing dependence on energy-intensive mechanical aeration (Ahirwar et al. 2025). These integrated photobioelectrochemical configurations facilitate the assimilation of inorganic nitrogen and phosphorus into algal biomass, contributing directly to eutrophication mitigation. In addition, photosynthetic carbon fixation enables the partial reutilization of carbon dioxide released during anodic microbial respiration, linking wastewater treatment with carbon management (Ahirwar et al. 2025; Luo et al. 2017).

Beyond pollutant removal, algal-assisted BES supports circular bioeconomy objectives by generating biomass that can be harvested and valorized into downstream products such as biofuels or biochemicals (Pandya et al. 2024). Life cycle assessment studies indicate that the environmental benefits of such systems are maximized when algae are cultivated directly within wastewater streams, thereby avoiding external fertilizer inputs and reducing the overall resource demand (Akinbuja et al. 2025).

2.6 Challenges and Limitation of BESs

Despite significant advancements in bioelectrochemical systems (BESs), several technical and ecological challenges continue to limit their large-scale implementation for eutrophic water remediation. One of the major limitations is the site-specific variability of native microbial communities. Indigenous microbial assemblages differ according to nutrient load, redox gradients, hydrological conditions, and seasonal environmental fluctuations (Shade, 2023). Even within a single aquatic ecosystem, electrogenic microbial populations may vary significantly across sediment layers and shoreline regions. Such heterogeneity complicates standardization of microbial inocula and affects the reproducibility of BES performance under different environmental conditions.

Native microbial communities also undergo ecological succession following introduction into BES reactors, resulting in shifts in dominant microbial taxa over time. These microbial dynamics may influence extracellular electron transfer efficiency, pollutant degradation capacity, and biofilm stability within the system. Therefore, improved understanding of microbial community interactions and long-term ecological adaptation remains essential for maintaining stable BES performance.

Although BESs are capable of reducing nutrient concentrations and biochemical oxygen demand (BOD), fluctuations in long-term power generation and electron transfer efficiency remain significant operational challenges. Excessive biofilm growth may increase diffusion limitations within deeper biofilm layers, thereby reducing effective electron transfer between microorganisms and electrode surfaces (Logan et al., 2012). In addition, cathode performance is frequently affected by oxygen limitation, electrode fouling, pH drift, and unstable redox conditions. Environmental fluctuations such as temperature variation, rainfall-driven dilution, and seasonal algal blooms may further destabilize BES operation under field conditions.

Scaling BESs from laboratory-scale systems to pilot and field applications presents additional engineering challenges. Most mechanistic studies involving electrogenic microorganisms have been conducted under highly controlled bench-scale conditions. However, large-scale systems encounter difficulties related to hydraulic mixing, mass transfer limitations, electrode spacing, and maintenance of stable biofilm growth (Kumar

et al., 2023). Natural aquatic environments also introduce competing microbial populations, protozoan grazing, sediment disturbances, and fluctuating nutrient loads that may alter system performance (Battin et al., 2007).

Economic and regulatory limitations also hinder widespread BES deployment. Large-scale conductive materials and electrodes must remain cost-effective, mechanically stable, and environmentally safe during prolonged operation. Furthermore, environmental regulations regarding microbe-based remediation technologies remain insufficiently defined in many regions (Nunes et al., 2022). Concerns related to unintended enrichment of pathogenic microorganisms, release of electrode-associated contaminants, and long-term ecological impacts require establishment of standardized biosafety assessment protocols and performance evaluation guidelines.

Therefore, future advancement of BES technologies requires interdisciplinary efforts involving microbial ecology, electrochemistry, reactor engineering, environmental monitoring, and policy development to improve scalability, operational stability, and field-scale applicability of BES-assisted eutrophic water remediation systems.

2.7 Future Perspective of BESs in Environmental Remediation

Bioelectrochemical systems (BESs) are increasingly being recognized as sustainable and multifunctional technologies for wastewater treatment, nutrient recovery, and environmental restoration. Future developments in BES research are expected to focus on improving extracellular electron transfer efficiency, electroactive biofilm stability, reactor scalability, and long-term operational performance under real environmental conditions. Recent advancements in nanostructured electrode materials, conductive polymers, and surface functionalization strategies have shown significant potential for enhancing microbial adhesion and electron transfer kinetics within BES platforms (Fathima et al., 2024; Jadhav 2022; Chang et al. 2021).

Hybrid BES configurations such as constructed wetland-microbial fuel cells (CW-MFCs), sediment microbial fuel cells (SMFCs), and algae-assisted BESs are expected to play an important role in decentralized wastewater treatment and eutrophic water remediation. Integration of photosynthetic microorganisms, nutrient recovery systems, and low-energy

remediation technologies may further improve sustainability and resource recovery efficiency within these systems (Chong et al. 2025; Elhenawy et al. 2022).

Recent interest has also emerged toward the application of artificial intelligence (AI), biosensors, and real-time monitoring systems for optimization of BES operation. AI-assisted monitoring may facilitate prediction of microbial behavior, biofilm dynamics, nutrient removal efficiency, and reactor performance under fluctuating environmental conditions (Gómez et al., 2025). Such smart monitoring approaches may improve process control and operational stability in field-scale BES applications (Unuofin et al. 2023).

Advances in molecular biology, metagenomics, and microbial community profiling are further expected to improve understanding of native microbial consortia and electroactive microorganisms involved in pollutant degradation and extracellular electron transfer. Identification of highly efficient electroactive microbial communities and optimization of microbial-electrode interactions may significantly enhance remediation efficiency and energy recovery potential.

Overall, BES technologies strongly align with circular bioeconomy and sustainable development goals by enabling simultaneous wastewater treatment, nutrient recovery, bioenergy generation, and environmental restoration (Guadalupe et al. 2024; Bhagat et al. 2025; Chong et al. 2025). Therefore, continued interdisciplinary research integrating microbiology, electrochemistry, environmental engineering, and materials science will be essential for translating BESs from laboratory-scale experimental systems to practical field-scale remediation technologies.

2.8 Research Gap and Rationale of Present Study

Although substantial progress has been achieved in the field of bioelectrochemical systems (BESs), several limitations and knowledge gaps remain regarding microbial behavior under electrically stimulated conditions, particularly in native eutrophic microbial communities. Most previous studies have primarily focused on electricity generation, reactor optimization, nutrient removal efficiency, and electrochemical performance, whereas comparatively limited attention has been given to preliminary

microbial aggregation and surface-associated growth behavior under electrophoretic conditions.

Furthermore, many existing studies utilize defined electroactive pure cultures or highly controlled synthetic microbial systems, which may not accurately represent the ecological complexity and adaptive behavior of native microbial consortia present within eutrophic environments. The interaction between naturally occurring microbial populations and electrically stimulated environments remains insufficiently understood, particularly with respect to microbial redistribution, aggregation dynamics, and early-stage biofilm-associated development.

In addition, limited studies have explored the effect of prolonged electric field exposure on microbial colony dynamics, oxidizable organic matter transformation, and surface-associated accumulation within simple electrophoretic chamber systems. Understanding these responses is important because microbial attachment and biofilm-associated growth strongly influence extracellular electron transfer, pollutant degradation, and long-term stability of bioelectrochemical systems.

Therefore, the present study was designed to investigate the effect of prolonged electrical stimulation on native microbial consortia obtained from eutrophic water samples using an electrophoretic chamber system. The study focused on evaluating changes in microbial colony dynamics, crystal violet retention, oxidizable organic content, and possible preliminary surface-associated biomass accumulation under electrically stimulated conditions. The findings may provide preliminary insight into microbial adaptation and aggregation behavior relevant to future development of BES-assisted eutrophic water remediation technologies.

CHAPTER 3

MATERIALS AND METHODS

3.1 Materials Required

3.1.1 Raw Materials

1. Eutrophic wastewater

3.1.2 Chemical and Reagents

1. Glucose
2. Ammonium Chloride (NH_4Cl)
3. Potassium dihydrogen phosphate (K_2HPO_4)
4. Magnesium sulphate (MgSO_4)
5. Potassium permanganate (KMnO_4)
6. Nutrient agar media
7. Sterile saline solution (0.85% NaCl)
8. Distilled water
9. Sulfuric acid (H_2SO_4)
10. Ethanol
11. Crystal violet
12. Acetone

3.1.3 Glassware and labwares

1. Beakers
2. Conical flasks
3. Centrifuge tubes (2ml and 15ml)
4. Tube rack
5. Measuring cylinders
6. Funnels
7. Glass rods
8. Pipettes with sterile tips
9. Watch glass
10. Measuring spoons
11. Sterile Petri plates
12. Spreader
13. Sample collection container
14. Quartz cuvettes
15. Burette
16. Burette stand with clamp
17. Amber bottle
18. Dropper
19. Wash bottle

3.1.4. Instruments and Equipments

1. Electrophoretic chamber with inbuilt anode and cathode assembly
2. DC power supply unit
3. UV-Visible spectrophotometer

4. Incubator
5. Autoclave
6. Analytical balance
7. pH meter
8. Magnetic stirrer
9. Refrigerator
10. Hot plate
11. Laminar hood

3.2 Sample Collection

Eutrophic sediment samples used in the present study were collected from the **Satpula Lake region**, New Delhi using sterile sample collection containers. The samples were collected from the surface sediment layer of the eutrophic water body under aseptic conditions to preserve the native microbial community structure.

Following collection, the samples were immediately transported to the laboratory for further experimental analysis. The collected sediment samples were stored at 4°C until further use.



Fig 3.1: Satpula Lake, New Delhi, showing eutrophic water conditions at the sampling site used in the present study.

The eutrophic sediment served as the source of native microbial consortia for electrophoretic biofilm induction studies due to the presence of environmentally adapted microbial populations capable of surviving under nutrient-rich conditions.

3.3 Preparation of Native Microbial Inoculum

Sediment and water samples collected from the eutrophic region of Satpula Lake, New Delhi, were used as the source of native microbial consortia. Approximately 5 g of sediment sample was mixed with 50 mL sterile saline solution (0.85% NaCl) and vortexed gently to obtain a microbial suspension. The suspension was allowed to settle for 20 minutes to separate larger sediment particles. The supernatant containing suspended native microbial consortia was carefully collected and used as the microbial inoculum for further experimental studies.

The prepared inoculum was used immediately for electrophoretic biofilm induction experiments to preserve microbial viability and ecological characteristics.

3.4 Preparation of Synthetic Nutrient Media

Synthetic nutrient media was prepared to simulate nutrient-rich eutrophic conditions for microbial growth and biofilm formation studies.

The nutrient media was prepared in 500 mL distilled water using the following composition:

Table 3.1: Composition of Synthetic Nutrient Media

Component	Quantity
Glucose	1 g
Ammonium chloride	0.5 g
Potassium dihydrogen phosphate (K ₂ HPO ₄)	0.25 g
Magnesium sulfate (MgSO ₄)	0.025 g

All components were dissolved thoroughly in distilled water using sterile glassware. The prepared medium was sterilized by autoclaving at 121°C for 15–20 min.

3.5 Preparation of Nutrient Agar Plates

Nutrient agar plates were prepared by dissolving 7.5 g of nutrient agar powder in 500 mL distilled water. The medium was heated gently with continuous stirring until complete dissolution of agar. The prepared medium was sterilized by autoclaving at 121°C for 15-20 min. Sterile petri plates were then poured with molten nutrient agar under aseptic conditions and allowed to solidify at room temperature.

The prepared agar plates were incubated at 37°C for approximately 30 min with lids slightly opened to facilitate drying of the agar surface prior to microbial inoculation.

3.6 Experimental Setup

Two experimental systems were established for comparative analysis of microbial biofilm formation under electrophoretic conditions.

3.6.1 Electrophoretic System

The electrophoretic chamber used in the present study consisted of integrated anodic and cathodic compartments connected directly to a DC power supply. No separate external electrodes were employed during the experimental procedure.

Prior to experimentation, the chamber was thoroughly cleaned using distilled water followed by 70% ethanol to minimize contamination. 225 ml of synthetic nutrient media was added into the chamber followed by inoculation with the prepared native microbial consortium.

A constant voltage of 10 V was applied throughout the experimental duration to facilitate microbial migration and biofilm formation under electrophoretic conditions.



Fig 3.2: Electrophoretic chamber connected to DC power supply used for electric field-assisted microbial treatment.

3.6.2 Control System

A non-electrified control system was maintained under identical experimental conditions without application of electric current. The control setup contained the same composition of synthetic nutrient media and microbial inoculum as used in the electrophoretic system.

3.6.3 Experimental Conditions

Both experimental systems were maintained under similar environmental conditions throughout the study period.

Table 3.2: Operational Parameters maintained during electrophoretic system

Parameter	Conditions
Experimental Duration	72h
Sampling Intervals	0, 24, 48, 72h
Voltage	10V

Periodic samples were collected from both systems for CFU analysis, potassium permanganate consumption test, and UV-Visible spectrophotometric analysis.

3.6.4 Electric Field Treatment

Following inoculation, the electrophoretic chamber was connected directly to a DC power supply through the integrated anodic and cathodic compartments of the chamber.

A constant voltage of 10 V was applied continuously for 72 h under static conditions at room temperature (25–28°C). Periodic sampling and visual monitoring were performed at 24 h intervals throughout the experimental duration.

3.7 Colony Forming Unit (CFU) Analysis

Microbial population dynamics within the electrophoretic chamber were evaluated using colony forming unit (CFU) analysis at different experimental intervals.

Samples were collected periodically from the electrophoretic chamber during the experimental duration. Aliquots obtained from the chamber were serially diluted using a sterile saline solution (0.85% NaCl) under aseptic conditions.

Appropriate dilutions were spread plated on nutrient agar plates using a sterile glass spreader. The inoculated plates were incubated at 37°C for 24 hours. Plates were kept upside down so that condensation does not interfere with surface.

After incubation the number of visible colonies was counted and recorded for comparative analysis of microbial population changes during electric field exposure.

The CFU was calculated using the following equation:

$$\text{CFU/ml} = \frac{\text{Number of colonies} \times \text{Dilution Factor}}{\text{Volume Plated (ml)}}$$

3.8 Potassium Permanganate Consumption Analysis

Potassium permanganate (KMnO_4) consumption analysis was performed to evaluate changes in oxidizable organic matter during electric field treatment.

3.8.1 Principle

Potassium permanganate acts as a strong oxidizing agent capable of oxidizing organic compounds present in eutrophic water samples. Reduction in KMnO_4 concentration indirectly indicates the presence and utilization of oxidizable organic matter within the system.

3.8.2 Preparation of KMnO_4 Solution

Approximately 0.0395 g potassium permanganate was dissolved in 125 mL distilled water. The solution was heated at 40-45°C for 10-15 min to ensure proper dissolution and stabilization. The prepared solution was stored in an amber-colored bottle until further use.

3.8.3 Procedure

Two sets of samples were prepared for potassium permanganate analysis:

- **Control sample:** non-electrified eutrophic water sample maintained under identical environmental conditions.
- **Experimental sample:** eutrophic water sample exposed to electrical stimulation in the electrophoretic chamber.

To each sample, sulfuric acid and distilled water were added under acidic conditions prior to titration. Potassium permanganate solution was then added dropwise from the burette until a faint permanent pink endpoint was observed. The volume of KMnO_4 consumed was recorded for comparative analysis.

Table 3.4 Composition Used for KMnO₄ Analysis:

Component	Quantity
Sample (control/electrophoretic)	5ml
Sulphuric acid (H ₂ SO ₄)	0.25ml
Distilled Water	2.25ml
Potassium Permanganate (KMnO ₄)	Added dropwise during titration



Fig 3.3: Experimental Setup used for KMNO₄ titration analysis

3.9 Crystal Violet Biofilm Assay and UV-Visible Spectrophotometric Analysis

Crystal violet (CV) assay was performed to evaluate biofilm-associated microbial biomass formed within the electrophoretic chamber after electric field treatment for 72h.

3.9.1 Principle

Crystal violet is a basic dye that binds to negatively charged components present in microbial cells and extracellular polymeric substances (EPS) of biofilms. The

amount of retained stain indirectly indicates the extent of biofilm formation and surface-associated microbial biomass.

3.9.2 Reagents Used

Table 3.5 Reagents Used for Crystal Violet Assay

Reagent	Quantity/Concentration
Crystal Violet Solution	0.1% (0.1g in 10ml dH ₂ O)
Distilled water	As required
Ethanol	As required
Acetone	30% (3ml in 10ml dH ₂ O)

3.9.3 Procedure

After 72h, visible slimy microbial aggregation was observed predominantly near the bottom surface, chamber walls, and around the cathodic region. The liquid medium present inside the chamber was carefully removed using dropper while retaining the attached slimy layer suspected to represent biofilm-associated biomass. Then chamber surfaces were gently rinsed with sterile saline twice to remove loosely suspended particles without disturbing the attached layer. Ethanol was then added as a fixative agent along the walls and incubated for 15 minutes at room temperature to facilitate fixation of attached biomass.

After fixation, 0.1% Crystal violet stain was added to the chamber and allowed to incubate for 15 minutes for staining of attached microbial layer. Excess stain was carefully removed, and the chamber was again washed gently using distilled water to eliminate unbound dye. The retained crystal violet associated with the attached microbial biomass was subsequently dissolved using acetone.

The acetone-solubilized crystal violet solution was collected and subjected to UV-Visible spectrophotometric analysis at 570 nm using acetone as blank. Absorbance values obtained from control and electrophoretically treated samples were compared

to evaluate relative microbial adhesion and possible biofilm formation under electrical stimulation.

3.10 Microscopic Observation

Microscopic examination was performed to observe microbial aggregation and suspended particulate structures present within samples collected from the electrophoretic chamber.

Samples collected after electric field treatment were placed on clean glass slides and observed under a light microscope using 10× and 40× magnifications. Wet mount preparation was performed without differential staining.

Observations were recorded based on the presence of particulate aggregates, clustered structures, suspended biomass, and possible microbial flocs formed under electrophoretic conditions.

Microscopic images obtained during the study were documented for comparative analysis of microbial aggregation behavior.

3.11 Data Recording and Statistical Analysis

Experimental observations including colony counts, crystal violet absorbance values, microscopic observations, and potassium permanganate consumption data were recorded throughout the study.

Graphical representation and comparative analysis of the obtained data were performed using Microsoft Excel. Experimental observations were interpreted comparatively between control and electrophoretically treated samples.

CHAPTER 4

RESULTS AND DISCUSSION

4.1 Formation of Biofilm in Electrophoretic Chamber

The electrophoretic chamber was operated at an applied voltage of 10 V for a duration of 72 h using native microbial inoculum collected from eutrophic water samples. Periodic visual observations were recorded at 24 h intervals to monitor microbial growth, biomass accumulation, and possible biofilm formation within the chamber.

During the initial 24 h of operation, the chamber appeared comparatively clear with no significant visible microbial accumulation. After 48 h, slight turbidity and faint slimy deposition became visible near the cathodic compartment and along the side walls of the chamber of electrophoretic system. By 72 h, a distinctly visible cloudy and slimy layer had developed predominantly near the cathode region, bottom surface, and adjacent chamber walls.

The observed slimy deposition near the cathodic compartment was considered indicative of preliminary biofilm-associated microbial aggregation under electrically stimulated conditions. In contrast, no prominent visible slimy layer or cloudy biomass accumulation was observed near the anodic compartment during the experimental period.

However, it is important to note that periodic sampling for colony forming unit (CFU) analysis and potassium permanganate consumption analysis was performed predominantly from the anodic side of the chamber at 24 h intervals. Repeated removal and disturbance of liquid from the anodic compartment may therefore have limited localized biomass retention and visible accumulation in that region. In comparison, the relatively undisturbed cathodic compartment permitted gradual retention and accumulation of slimy microbial biomass along the chamber surfaces.

The preferential biomass accumulation observed near the cathode may therefore be associated with a combination of electric field influence, electrokinetic microbial

redistribution, selective microbial survival, and reduced disturbance of the cathodic region during sampling. Native microbial consortia present in eutrophic environments are known to respond to electrical stimulation through enhanced microbial adhesion, extracellular polymeric substance (EPS) secretion, and surface colonization.

The progressive increase in visible biomass from 48 h to 72 h suggests microbial adaptation and enrichment within the electrophoretic environment. These observations are consistent with previous studies reporting electrically stimulated microbial aggregation and biofilm formation in bioelectrochemical systems.

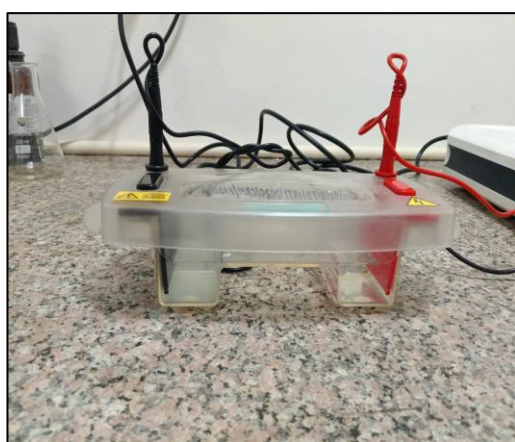

Fig 4.1: Electrophoretic chamber connected to DC power supply for 72 hours

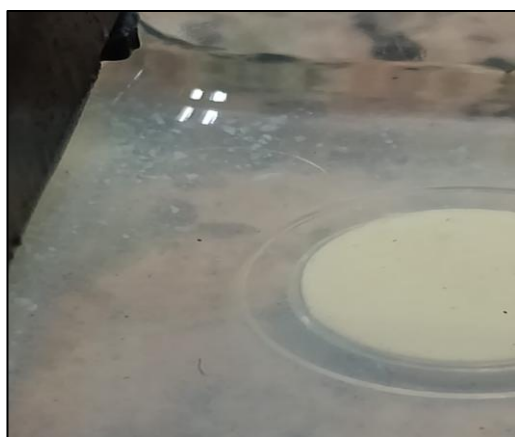

Fig 4.2: Visible cloudy and surface-associated accumulation observed within the electrophoretic chamber during prolonged electrical incubation.

4.2 Colony Forming Unit Analysis

Colony Forming Unit (CFU) analysis was performed to evaluate microbial viability within the electrophoretic chamber during electrically stimulated operation. Samples collected from the electrophoretic system at 24 h intervals were plated on nutrient agar medium and incubated at 37°C for microbial growth analysis.

Visible microbial colonies were observed following incubation, confirming the presence of viable microbial populations within the electrophoretic chamber under the applied electric field. However, the number of colonies gradually decreased with increasing duration of electrophoretic treatment. The highest colony count was observed during the initial stages of incubation, whereas comparatively lower colony numbers were recorded after prolonged exposure to the electric field.

The gradual reduction in colony count over time may indicate electrical stress, nutrient depletion, selective microbial survival, or adaptation of only electrically tolerant microbial populations within the chamber. Despite the decline in CFU count, visible slimy and cloudy biomass accumulation was observed during later stages of incubation, suggesting that microbial cells may have progressively shifted from planktonic growth toward surface-associated aggregation and preliminary biofilm formation.

The observations indicate that electrical stimulation influenced microbial growth dynamics and may have promoted selective enrichment of microbial populations capable of surviving under electrophoretic conditions. Similar trends of reduced free-floating microbial populations accompanied by increased surface-associated biomass have been reported in bioelectrochemical systems during biofilm maturation.

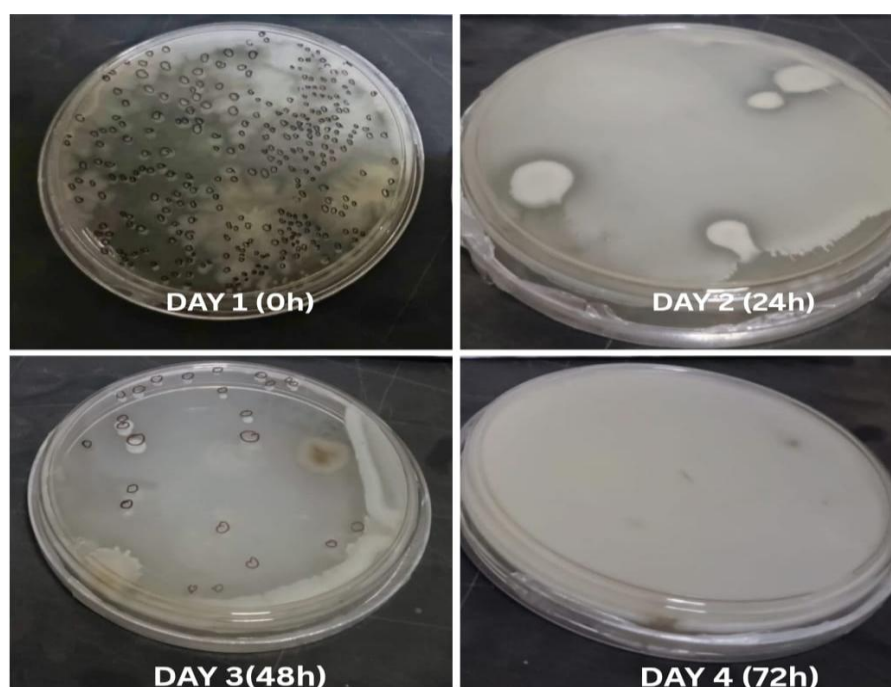

Fig 4.3: Temporal variation in microbial colony formation observed during CFU analysis of samples collected from the electrophoretic chamber at different incubation intervals (0 h, 24 h, 48 h, and 72 h).

Table 4.1 Comparative analysis of microbial population (CFU/ml) in control and electrophoretic systems during incubation

Incubation Time	Control system (CFU/ml)	Electrophoretic System (CFU/ml)
0h	3.25×10^3	3.20×10^3
24h	2.70×10^3	1.0×10^3
48h	1.90×10^3	0.45×10^3
72h	1.20×10^3	0.10×10^3

4.3 Potassium Permanganate (KMnO₄) Analysis

The Potassium Permanganate (KMnO₄) analysis was performed to investigate changes in oxidizable organic constituents and microbial activity within the electrophoretic system during electrically stimulated incubation. KMnO₄ acts as a strong oxidizing agent under

acidic conditions, and variation in its consumption reflects changes in organic load and biologically active components present in the samples.

During the initial stage of incubation, the electrophoretic sample exhibited comparatively higher KMnO_4 consumption than the control system. This observation suggests the presence of elevated oxidizable organic matter and active suspended microbial populations within the chamber immediately after inoculation. A pronounced reduction in the characteristic pink coloration of KMnO_4 solution was observed during titration of the electrophoretic samples, indicating active oxidation of organic and microbial constituents.

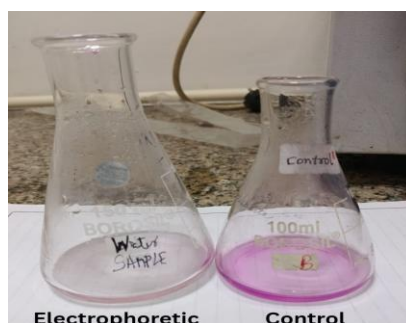

Fig 4.4: Representative KMnO_4 titration endpoint observed during analysis of electrophoretic samples.

Table 4.2 Variation in KMnO_4 consumption during electrically stimulated incubation

Incubation Time	KMnO_4 Consumed in Control (ml)	KMnO_4 Consumed in Electrophoretic Sample (ml)
0h	0.5	2
24h	0.3	0.8
48h	0.2	0.5
72h	0.1	1

The endpoint was determined by persistence of faint pink coloration during KMnO_4 titration under acidic conditions.

As the incubation period progressed from 24 h to 48 h, a gradual decline in KMnO_4 consumption was observed in the electrophoretic system. This trend may indicate depletion of readily oxidizable substrates, reduction in free-floating microbial biomass, and physiological adaptation of microbial populations under prolonged electrical exposure. The decline observed in KMnO_4 consumption correlated with the progressive reduction in CFU counts during the same incubation period, suggesting that suspended microbial activity within the bulk liquid phase was decreasing over time.

Interestingly, a subsequent increase in KMnO_4 consumption was observed during the later stage of incubation (72 h). This increase may be associated with accumulation of extracellular polymeric substances (EPS), release of microbial metabolites, or localized biomass enrichment within the chamber. The observation is further supported by the visible cloudy and slimy deposition detected near the cathodic region and side walls during prolonged operation.

The fluctuating pattern of KMnO_4 consumption therefore indicates that the applied electric field influenced both microbial growth dynamics and organic matter transformation within the electrophoretic environment. Rather than showing simple microbial inhibition, the results suggest a gradual shift from suspended planktonic growth toward surface-associated microbial aggregation and possible preliminary biofilm formation. Such behavior has also been reported in electrically stimulated microbial systems where electrochemical stress selectively alters microbial survival, metabolic activity, and biofilm-associated adaptation.

4.4 Crystal Violet (CV) Assay and UV-Visible Spectrophotometric Analysis

The Crystal violet staining demonstrated visible retention of purple coloration on the inner surfaces of the electrophoretic chamber following prolonged electrically stimulated incubation after 72 hours. More prominent stain retention and slimy deposition were observed near the cathodic region, chamber walls, and bottom surface compared to the anodic side.

The increased retention of crystal violet stain in the electrophoretic system suggests accumulation of surface-associated biomass within the chamber. Since crystal violet binds

to attached microbial cells and extracellular polymeric substances (EPS), the retained stain may indicate preliminary microbial aggregation and possible biofilm-associated growth under electrically stimulated conditions.

UV-Visible spectrophotometric analysis performed at 570 nm further supported the crystal violet observations. Following acetone treatment, the retained crystal violet stain was solubilized and analyzed spectrophotometrically.

Table 4.3 Absorbance values obtained after crystal violet extraction at 570nm

Sample	Absorbance (570nm)
Electrophoretic Sample	0.288
Control Sample	0.112

The electrophoretic sample exhibited an absorbance value of **0.288** at 570 nm higher than control, suggesting retention of crystal violet stain within the chamber, indicating possible preliminary surface-associated biomass accumulation and early-stage biofilm-associated growth under electrically stimulated conditions.



Fig 4.5: Crystal violet retention observed in the electrophoretic chamber after 72h incubation.



Fig 4.6: UV-Visible spectrophotometric analysis of crystal violet extract at 570 nm

The combined CV and UV-Visible observations correlated with the progressive reduction in CFU counts observed during incubation. While free-floating microbial colonies gradually decreased over time, localized surface-associated accumulation became increasingly visible within the chamber. This trend suggests that prolonged electric field exposure may have influenced microbial redistribution and promoted attached biomass accumulation rather than sustained planktonic growth alone.

However, because eutrophic samples contain mixed microbial populations along with dissolved salts and suspended particulates, contribution from electrochemically induced mineral deposition or salt precipitation cannot be completely excluded. Therefore, the observed crystal violet retention may represent combined microbial attachment, extracellular polymeric substance accumulation, and possible inorganic deposition within the electrophoretic environment.

More pronounced accumulation near the cathodic region may be associated with localized electrochemical conditions, pH variation, ionic redistribution, or preferential enrichment of electrically tolerant microbial populations under prolonged electric field exposure.

Overall, the combined crystal violet and UV-Visible analyses suggest that electrical stimulation influenced biomass redistribution and promoted localized surface-associated accumulation within the electrophoretic chamber.

4.5 Microscopic Analysis

Microscopic examination of samples collected from the electrophoretic chamber under 10× magnification revealed irregular particulate and aggregated structures within the system after prolonged electrically stimulated incubation of 72h. Visible clustered and slimy accumulations correlated with the cloudy deposition observed macroscopically in the chamber.

The observations suggest possible localized biomass accumulation and preliminary surface-associated aggregation under electric field exposure. However, due to limited magnification and absence of differential staining techniques, definitive microbial identification or confirmation of mature biofilm formation could not be established.

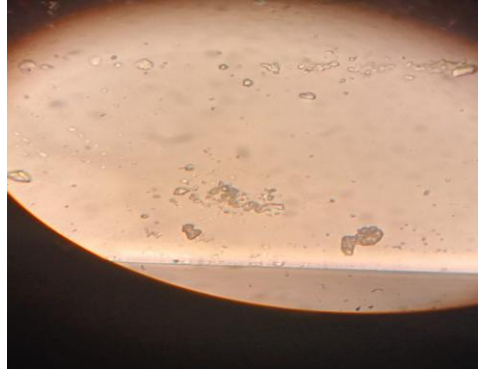

Fig 4.7: Microscopic observation (10× magnification) showing aggregated and clustered particulate structures obtained from the electrophoretic chamber after prolonged electrically stimulated incubation.

4.6 Discussion

The present study demonstrated that prolonged electrical stimulation influenced microbial behavior and biomass distribution within the electrophoretic chamber system. Progressive reduction in planktonic CFU counts observed under electrophoretic conditions suggested suppression or redistribution of free-floating microbial populations during incubation. In contrast, the comparatively slower decline observed in the control system indicated that electrical exposure contributed significantly to the observed microbial changes.

Simultaneously, visible cloudy and slimy accumulation detected near the chamber walls and cathodic region suggested localized microbial aggregation under electrically stimulated conditions. Crystal violet staining further supported this observation through enhanced dye retention within the electrophoretic chamber. The UV–Visible absorbance value of 0.288 obtained at 570 nm indicated moderate crystal violet retention, suggesting possible preliminary surface-associated biomass accumulation and early-stage biofilm-associated growth.

Potassium permanganate analysis also revealed variation in oxidizable organic constituents during incubation. Initial higher permanganate consumption may be associated with active microbial metabolism and elevated organic content, whereas gradual reduction during later stages suggested depletion of readily oxidizable substrates and decline in suspended microbial activity. These observations correlated with CFU reduction trends obtained during incubation.

Microscopic examination at 10× magnification further revealed clustered and aggregated particulate structures within samples collected from the electrophoretic chamber. Although definitive confirmation of mature biofilm formation could not be established due to limited magnification and absence of advanced staining or molecular characterization, the combined observations collectively suggest that prolonged electrical stimulation may have promoted microbial redistribution and preliminary surface-associated aggregation within the system.

Overall, the study indicates that electrically stimulated environments may influence native microbial consortia by altering microbial growth dynamics, biomass localization, and possible early biofilm-associated behavior relevant to future bioelectrochemical remediation applications.

4.7 Conclusion

The combined experimental observations demonstrated that prolonged electrical stimulation influenced microbial behavior, oxidizable organic content, and biomass distribution within the electrophoretic chamber. Progressive reduction in CFU counts during incubation indicated a decline in free-floating planktonic microbial populations under electrically stimulated conditions. Simultaneously, visible cloudy and slimy deposition observed near the cathodic region and chamber walls suggested localized accumulation within the system.

Crystal violet retention, UV-Visible spectrophotometric analysis, and microscopic observations collectively supported the possibility of preliminary surface-associated biomass aggregation within the electrophoretic chamber. The UV absorbance value of

0.288 at 570 nm indicated retention of crystal violet stain and suggested the presence of attached biomass within the system. Microscopic examination further revealed clustered and aggregated particulate structures that correlate with visual and staining observations. KMnO_4 analysis demonstrated fluctuating consumption patterns throughout incubation, indicating dynamic physicochemical and microbial changes occurring under prolonged electrical exposure. These variations may be associated with microbial adaptation, transformation of oxidizable organic matter, extracellular polymeric substance accumulation, ionic redistribution, and electrochemical stress within the electrophoretic environment.

Although definitive confirmation of mature biofilm formation could not be established due to limited magnification and absence of advanced characterization techniques, the collective findings suggest that electrical stimulation may have promoted redistribution of microbial populations from suspended planktonic form toward localized surface-associated aggregation.

Overall, the study provides preliminary insight into the interaction between native microbial consortia and electrically stimulated environments. The findings indicate the potential applicability of electrophoretic and bioelectrochemical approaches for microbial enrichment, wastewater treatment, eutrophic water remediation, and future biofilm-based bioelectrochemical systems (BES). Further studies involving molecular characterization, scanning electron microscopy (SEM), electrochemical analysis, and advanced biofilm imaging techniques may provide deeper understanding of microbial adaptation and electroactive biofilm development under electrically stimulated conditions.

REFERENCES

1. Addagada L, Goel M, Shahid MK, Prabhu SV, Chand S, Sahoo NK, Rout PR (2023) Tricks and tracks in resource recovery from wastewater using bio-electrochemical systems (BES): A systematic review on recent advancements and future directions. *J Water Process Eng* 56:104580. <https://doi.org/10.1016/j.jwpe.2023.104580>.
2. Agudelo-Escobar LM, Cabrera SE, Avignone Rossa C (2022) A bioelectrochemical system for waste degradation and energy recovery from industrial coffee wastewater. *Front Chem Eng* 4:814987. <https://doi.org/10.3389/fceng.2022.814987>.
3. Ahirwar A, Khan MJ, Khandelwal P, Singh G, Harish, Vinayak V, Ghangrekar MM (2025) Bioelectromics of a photosynthetic microalgae assisted microbial fuel cell for wastewater treatment and value added production. *Sci Rep* 15:30196. <https://doi.org/10.1038/s41598-025-13271-1>.
4. Ahmad A, Priyadarshani M, Das S, Ghangrekar MM (2022) Role of bioelectrochemical systems for the remediation of emerging contaminants from wastewater: A review. *J Basic Microbiol* 62:201–222. <https://doi.org/10.1002/jobm.202100368>.
5. Akinbuja O, Orta SV, Boodhoo K (2025) Life cycle assessment of microalgae-assisted microbial fuel cells. *Int J Life Cycle Assess* 30:2133–2144. <https://doi.org/10.1007/s11367-025-02518-8>.
6. Al-Sahari M, Al-Gheethi A, Radin Mohamed RMS, Noman E, Naushad M, Rizuan MB, Vo D-VN, Ismail N (2021) Green approach and strategies for wastewater treatment using bioelectrochemical systems: A critical review of fundamental concepts, applications, mechanism, and future trends. *Chemosphere* 285:131373. <https://doi.org/10.1016/j.chemosphere.2021.131373>.
7. Angelaalincy MJ, Navanietha Krishnaraj R, Shakambari G, Ashokkumar B, Kathiresan S, Varalakshmi P (2018) Biofilm engineering approaches for improving the performance of microbial fuel cells and bioelectrochemical systems. *Front Energy Res* 6:63. <https://doi.org/10.3389/fenrg.2018.00063>.

8. Barbosa SG, Rodrigues T, Peixoto L, Kuntke P, Alves MM, Pereira MA, Ter Heijne A (2019) Anaerobic biological fermentation of urine as a strategy to enhance the performance of a microbial electrolysis cell (MEC). *Renew Energy* 139:936–943.
9. Battin TJ, Sloan WT, Kjelleberg S, Daims H, Head IM, Curtis TP, Eberl L (2007) Microbial landscapes: New paths to biofilm research. *Nat Rev Microbiol* 5:76–81. <https://doi.org/10.1038/nrmicro1556>.
10. Bazina N, Ahmed TG, Almdaaf M, Jibia S, Sarker M (2023) Power generation from wastewater using microbial fuel cells: A review. *J Biotechnol* 374:17–30. <https://doi.org/10.1016/j.jbiotec.2023.07.006>.
11. Bhagat MS, Mevada C, Shah J, Rasheed MA, Mäntysalo M (2025) Zero-discharge, self-sustained 3D-printed microbial electrolysis cell for biohydrogen production: A review. *Chem Commun*. <https://doi.org/10.1039/D5CC00103J>.
12. Ceballos-Escalera A, Pous N, Baneras L, Balaguer MD, Puig S (2024) Advancing towards electro-bioremediation scaling-up: On-site pilot plant for successful nitrate-contaminated groundwater treatment. *Water Res* 256:121618. <https://doi.org/10.1016/j.watres.2024.121618>.
13. Cerrillo M, Riau V, Bonmatí A (2023) Recent advances in bioelectrochemical systems for nitrogen and phosphorus recovery using membranes. *Membranes* 13:186. <https://doi.org/10.3390/membranes13020186>.
14. Chang IS et al. (2021) Microfluidic MFC platforms for bioelectrochemical research. *Biosens Bioelectron* 177:112994. <https://doi.org/10.3390/microorganisms8111841>
15. Chong PL, Chuah JH, Chow CO, Ng PK (2025) Plant microbial fuel cells: A comprehensive review of influential factors, innovative configurations, diverse applications, persistent challenges, and promising prospects. *Int J Green Energy* 22:599–648. <https://doi.org/10.1080/15435075.2024.2421325>.
16. Conners EM, Rengasamy K, Bose A (2022) Electroactive biofilms: How microbial electron transfer enables bioelectrochemical applications. *J Ind Microbiol Biotechnol* 49:kuac012. <https://doi.org/10.1093/jimb/kuac012>.

17. Corona-Martínez DA, Martínez-Amador SY, Rodríguez-De la Garza JA, Laredo-Alcalá EI, Pérez-Rodríguez P (2025) Recent advances in scaling up bioelectrochemical systems: A review. *BioTech* 14:8. <https://doi.org/10.3390/biotech14010008>.
18. Correll DL (1998) The role of phosphorus in the eutrophication of receiving waters: A review. *Crit Rev Plant Sci* 17:359–380. <https://doi.org/10.1080/21622515.2013.861877>.
19. Curtis TP, Sloan WT (2004) Prokaryotic diversity and its limits. *Nat Rev Microbiol* 2:249–256. <https://doi.org/10.1016/j.mib.2004.04.010>.
20. Das I, Ghangrekar MM, Satyakam R, Srivastava P, Khan S, Pandey HN (2020) On-site sanitary wastewater treatment system using 720-L stacked microbial fuel cell: Case study. *J Hazard Toxic Radioact Waste* 24:04020025. [https://doi.org/10.1061/\(ASCE\)HZ.2153-5515.0000518](https://doi.org/10.1061/(ASCE)HZ.2153-5515.0000518).
21. Das S, Mishra A, Ghangrekar MM (2020a) Concomitant production of bioelectricity and hydrogen peroxide leading to the holistic treatment of wastewater in microbial fuel cell. *Chem Phys Lett* 759:137986. <https://doi.org/10.1016/j.cplett.2020.137986>.
22. Das S, Raj R, Das S, Ghangrekar MM (2021) A sustainable approach for the production of green energy with the holistic treatment of wastewater through microbial electrochemical technologies: A review. *Front Sustain* 2:792028. <https://doi.org/10.3389/frsus.2021.792028>.
23. Elhenawy S, Khraisheh M, AlMomani F, Al-Ghouti M, Hassan MK (2022) From waste to watts: Updates on key applications of microbial fuel cells in wastewater treatment and energy production. *Sustainability* 14:955. <https://doi.org/10.3390/su14020955>.
24. Esfandyari M, Jafari D, Azami H (2024) Microbial fuel cells for energy production in wastewater treatment plants: A review. *Biofuels* 15:743–753. <https://doi.org/10.1080/17597269.2023.2294227>.
25. Falkowski PG, Fenchel T, DeLong EF (2008) The microbial engines that drive Earth's biogeochemical cycles. *Science* 320:1034–1039. <https://doi.org/10.1126/science.1153213>.
26. Fathima A, Ilankoon IMSK, Zhang Y, Chong MN (2024) Scaling up of dual-chamber microbial electrochemical systems – An appraisal using systems design approach. *Sci Total Environ* 912:169186. <https://doi.org/10.1016/j.scitotenv.2023.169186>.

27. Gadkari S, Shemfe M, Sadhukhan J (2019) Microbial fuel cells: A fast converging dynamic model for assessing system performance based on bioanode kinetics. *Int J Hydrogen Energy* 44:15377–15386. <https://doi.org/10.1016/j.ijhydene.2019.04.065>.
28. Garbini GL, Barra Caracciolo A, Grenni P (2023) Electroactive bacteria in natural ecosystems and their applications in microbial fuel cells for bioremediation: A review. *Microorganisms* 11:1255. <https://doi.org/10.3390/microorganisms11051255>.
29. Glibert PM (2020) Harmful algal blooms: From ecosystems to socioecosystems. *Harmful Algae* 91:101583. <https://doi.org/10.1016/j.hal.2019.03.001>.
30. Gómez, M. E. P., Park, E., Zheng, Y., Bassi, A., & Liu, T. (2025). Exploring the Application of Artificial Intelligence for Bioelectrochemical Systems: A Review of Recent Research. *Green Energy and Resources*, 100141. <https://doi.org/10.1016/j.gerr.2025.100141>.
31. Guadalupe JJ, Pazmiño-Vela M, Pozo G, Vernaza W, Ochoa-Herrera V, Torres MDL, Torres AF (2024) Metagenomic analysis of microbial consortia native to the Amazon, Highlands, and Galapagos regions of Ecuador with potential for wastewater remediation. *Environ Microbiol Rep* 16:e13272. <https://doi.org/10.1111/1758-2229.13272>.
- 32.
33. Guan CY, Tseng YH, Tsang DC, Hu A, Yu CP (2019) Wetland plant microbial fuel cells for remediation of hexavalent chromium contaminated soils and electricity production. *J Hazard Mater* 365:137–145. <https://doi.org/10.1016/j.jhazmat.2018.10.086>.
34. Guo W, Ying X, Zhao N, Yu S, Zhang X, Feng H, Zhang Y, Yu H (2023) Interspecies electron transfer between *Geobacter* and denitrifying bacteria for nitrogen removal in bioelectrochemical system. *Chem Eng J* 455:139821. <https://doi.org/10.1016/j.cej.2022.139821>.
35. Gustave W, Yuan ZF, Sekar R, Chang HC, Zhang J, Wells M et al. (2018) Arsenic mitigation in paddy soils by using microbial fuel cells. *Environ Pollut* 238:647–655. <https://doi.org/10.1016/j.envpol.2018.03.085>.
36. Hazzan OO, Zhao B, Xiao Y (2023) Strategies for enhancing extracellular electron transfer in environmental biotechnology: A review. *Appl Sci* 13:12760. <https://doi.org/10.3390/app132312760>.

37. Huisman J, Codd GA, Paerl HW, Ibelings BW, Verspagen JMH, Visser PM (2018) Cyanobacterial blooms. *Nat Rev Microbiol* 16:471–483. <https://doi.org/10.1038/s41579-018-0040-1>.
38. Ivanov R, Genova P, Nikolova K, Angelov A (2025) Integration of SMFC-based biosensor in constructed wetland for real time monitoring and bioremediation of heavy metals contaminated waters. *Sustain Extr Process Raw Mater* 6:29–33. <https://doi.org/10.58903/dw18920964>.
39. Jadhav DA et al. (2022) Carbon-based electrodes for microbial fuel cells. *Renew Sustain Energy Rev* 158:112118. <https://doi.org/10.1039/D5MH00344J>.
40. Jafary T, Mousavi A, Yeneneh AM, Al-Kalbani MS, Al-Wahaibi BM (2026) Recent advances in scaling up microbial fuel cell systems for wastewater treatment, energy recovery, and environmental sustainability. *Sustainability* 18:638. <https://doi.org/10.3390/su18020638>
41. Jatoi AS, Nguyen HM, Jeyapaul AS (2026) From waste to resource: Microbial pathways for sustainable food production. *Sustain Food Technol.* <https://doi.org/10.1039/D5FB00287>.
42. Jiang J, He P, Luo Y, Peng Z, Jiang Y, Hu Y et al. (2023) The varied roles of pilA-N, omcE, omcS, omcT, and omcZ in extracellular electron transfer by *Geobacter sulfurreducens*. *Front Microbiol* 14:1251346. <https://doi.org/10.3389/fmicb.2023.1251346>.
43. Jin X, Wang W, Yan Z, Xu D (2024) The important role of denitrifying exoelectrogens in single-chamber microbial fuel cells after nitrate exposure. *Separations* 11:187. <https://doi.org/10.3390/separations11060187>.
44. Karimi Alavijeh M, Mardanpour MM, Yaghmaei S (2015) Modeling of multi-population microbial fuel and electrolysis cells based on the bioanode potential conditions. *Hydrogen Fuel Cell Energy Storage* 1:247–260. <https://doi.org/10.22104/IJHFC.2015.176>.
45. Kumar S, Singh A, Sharma V (2023) Integrated photosynthetic microbial fuel cells for nutrient removal and electricity generation in eutrophic waters. *J Environ Manage* 336:117671. <https://doi.org/10.1016/j.jics.2025.102041>.

46. Kumar VK, Manangath SP, Gajalakshmi S (2023) Innovative pilot-scale constructed wetland-microbial fuel cell system for enhanced wastewater treatment and bioelectricity production. *Chem Eng J* 460:141686. <https://doi.org/10.1016/j.cej.2023.141686>.
47. Lavanya G, Goel M, Shahid MK, Prabhu SV, Chand S, Sahoo NK, Rout PR (2023) Tricks and tracks in resource recovery from wastewater using bio-electrochemical systems (BES): A systematic review on recent advancements and future directions. *J Water Process Eng* 56:104580. <https://doi.org/10.1016/j.jwpe.2023.104580>.
48. Li H, Tian Y, Qu Y, Qiu Y, Liu J, Feng Y (2017) A pilot-scale benthic microbial electrochemical system (BMES) for enhanced organic removal in sediment restoration. *Sci Rep* 7:39802. <https://doi.org/10.1038/srep39802>.
49. Liang P, Duan R, Jiang Y, Zhang X, Qiu Y, Huang X (2018) One-year operation of 1000-L modularized microbial fuel cell for municipal wastewater treatment. *Water Res* 141:1–8. <https://doi.org/10.1016/j.watres.2018.04.066>.
50. Liang M, Luo G, Lei P (2025) Recent advances in bioelectrochemical approaches for sustainable environmental remediation. *Int J Electrochem Sci* 101077. <https://doi.org/10.1016/j.ijoes.2025.101077>.
51. Lin CW, Alfanti LK, Cheng YS, Liu SH (2022) Enhancing bioelectricity production and copper remediation in constructed single-medium plant sediment microbial fuel cells. *Desalination* 542:116079. <https://doi.org/10.1016/j.desal.2022.116079>.
52. Liu S, Qiu D, Lu F, Wang Y, Wang Z, Feng X, Pyo SH (2022) *Acorus calamus* L. constructed wetland-microbial fuel cell for Cr (VI)-containing wastewater treatment and bioelectricity production. *J Environ Chem Eng* 10:107801. <https://doi.org/10.1016/j.jece.2022.107801>.
53. Logan BE, Hamelers B, Rozendal R, Schröder U, Keller J, Freguia S et al. (2006) Microbial fuel cells: Methodology and technology. *Environ Sci Technol* 40:5181–5192. <https://doi.org/10.1021/es0605016>.
54. Logan BE, Rabaey K (2012) Conversion of wastes into bioelectricity and chemicals by using microbial electrochemical technologies. *Science* 337:686–690. <https://doi.org/10.1126/science.1217412>.

55. Lovley DR (2017) Electrically conductive pili: Biological function and potential applications in electronics. *Curr Opin Electrochem* 4:190–198. <https://doi.org/10.1016/j.coelec.2017.08.015>.
56. Luo S, Berges JA, He Z, Young EB (2017) Algal-microbial community collaboration for energy recovery and nutrient remediation from wastewater in integrated photobioelectrochemical systems. *Algal Res* 24:527–539. <https://doi.org/10.1016/j.algal.2016.10.006>.
57. McCarty PL, Bae J, Kim J (2011) Domestic wastewater treatment as a net energy producer—can this be achieved? *Environ Sci Technol*. <https://doi.org/10.1021/es2014264>.
58. Nguyen HTT, Le GTH, Park SG, Jadhav DA, Le TTQ, Kim H, Vinayak V, Lee G, Yoo K, Song YC, Chae KJ (2024) Optimizing electrochemically active microorganisms as a key player in the bioelectrochemical system: Identification methods and pathways to large-scale implementation. *Sci Total Environ* 914:169766. <https://doi.org/10.1016/j.scitotenv.2023.169766>.
59. Nidheesh PV, Ganiyu SO, Kuppam C, Mousset E, Samsudeen N, Olvera-Vargas H, Kumar G (2022) Bioelectrochemical cells as a green energy source for electrochemical treatment of water and wastewater. *J Water Process Eng* 50:103232. <https://doi.org/10.1016/j.jwpe.2022.103232>.
60. Nunes LM, da Silva JF, Bicalho ST (2022) Environmental biosafety governance for microbial biotechnologies. *Environ Sci Policy* 136:244–253. <https://doi.org/10.1016/j.envsci.2022.07.002>.
61. Ojha R, Pradhan D (2024) The potential of microbial fuel cell for converting waste to energy: An overview. *Sustain Chem Environ* 100196. <https://doi.org/10.1016/j.scenv.2024.100196>.
62. Ouyang X et al. (2023) Constructed wetland microbial fuel cells for decentralized wastewater remediation. *Water Res* 230:119391. <https://doi.org/10.1088/1742-6596/2044/1/012029>.
63. Paerl HW, Gardner WS, Havens KE, Joyner AR, McCarthy MJ, Newell SE, Qin B, Scott JT (2016) Mitigating cyanobacterial harmful algal blooms in aquatic ecosystems impacted

- by climate change and anthropogenic nutrients. *Harmful Algae* 54:213–222. <https://doi.org/10.1016/j.hal.2015.09.009>.
64. Pandya RS, Kaur T, Bhattacharya R, Bose D, Saraf D (2024) Harnessing microorganisms for bioenergy with microbial fuel cells: Powering the future. *Water-Energy Nexus* 7:1–12. <https://doi.org/10.1016/j.wen.2023.11.004>.
65. Patel D, Bapodra SL, Madamwar D, Desai C (2021) Electroactive bacterial community augmentation enhances the performance of a pilot scale constructed wetland microbial fuel cell for treatment of textile dye wastewater. *Bioresour Technol* 332:125088. <https://doi.org/10.1016/j.biortech.2021.125088>.
66. Patil SA, Hägerhäll C, Gorton L (2012) Electron transfer mechanisms between microorganisms and electrodes in bioelectrochemical systems. *Bioanal Rev* 4:159–192. <https://doi.org/10.1007/s12566-012-0033-x>.
67. Perera GLEP, Maeda M, Somura H, Nakano C, Nishina Y (2023) Iron-added sediment microbial fuel cells to suppress phosphorus release from sediment in an agricultural drainage. *J Water Environ Technol* 21:237–248. <https://doi.org/10.2965/jwet.23-040>.
68. Prosser JI, Bohannon BJM, Curtis TP, Ellis RJ, Firestone MK, Freckleton RP et al. (2007) The role of ecological theory in microbial ecology. *Nat Rev Microbiol* 5:384–392. <https://doi.org/10.1038/nrmicro1643>.
69. Qin B, Luo H, Liu G, Zhang R, Chen S, Hou Y, Luo Y (2012) Nickel ion removal from wastewater using the microbial electrolysis cell. *Bioresour Technol* 121:458–461. <https://doi.org/10.1016/j.biortech.2012.06.068>.
70. Rabaey K, Read ST, Clauwaert P, Freguia S, Bond PL, Blackall LL, Keller J (2008) Cathodic oxygen reduction catalyzed by bacteria in microbial fuel cells. *ISME J* 2:519–527. <https://doi.org/10.1038/ismej.2008>.
71. Shade A (2023) Microbiome rescue: Directing resilience of environmental microbial communities. *Curr Opin Microbiol*. <https://doi.org/10.1016/j.mib.2022.102263>.
72. Sharma M, Jalalah M, Alsareii SA, Harraz FA, Xue W, Thakur N et al. (2024) Microalgal cycling in the cathode of microbial fuel cells (MFCs) induced oxygen reduction reaction (ORR) and electricity: A biocatalytic process for clean energy. *Chem Eng J* 479:147431. <https://doi.org/10.1016/j.cej.2023.147431>.

73. Singh A, Kaushik A (2021) Removal of Cd and Ni with enhanced energy generation using biocathode microbial fuel cell: Insights from molecular characterization of biofilm communities. *J Clean Prod* 315:127940. <https://doi.org/10.1016/j.jclepro.2021.127940>.
74. Sun D, Chen J, Huang H, Liu W, Ye Y, Cheng S (2016) The effect of biofilm thickness on electrochemical activity of *Geobacter sulfurreducens*. *Int J Hydrogen Energy* 41:16523–16528. <https://doi.org/10.1016/j.ijhydene.2016.04.163>.
75. Szakács S, Koók L, Pientka Z, Otmar M, Zitka J, Brožová L et al. (2025) Demonstration of a novel, polyaniline film-coated composite membrane as an efficient separator for microbial fuel cells operated in the long-term. *Chem Eng J Adv* 100824. <https://doi.org/10.1016/j.cej.2025.100824>.
76. Tao L, Song M, Jiang G (2023) Enhanced depolluting capabilities of microbial bioelectrochemical systems by synthetic biology. *Synth Syst Biotechnol* 8:341–348. <https://doi.org/10.1016/j.synbio.2023.05.005>.
77. Tian T, Fan X, Feng M, Su L, Zhang W, Chi H, Fu D (2019) Flavin-mediated extracellular electron transfer in Gram-positive bacteria *Bacillus cereus* DIF1 and *Rhodococcus ruber* DIF2. *RSC Adv* 9:40903–40909. <https://doi.org/10.1039/c9ra08045g>.
78. Ueki T, Nevin KP, Rotaru AE, Wang LY, Ward JE, Woodard TL, Lovley DR (2018) *Geobacter* strains expressing poorly conductive pili reveal constraints on direct interspecies electron transfer mechanisms. *mBio* 9:e01273-18. <https://doi.org/10.1128/mBio.01273-18>.
79. Unuofin JO, Iwarere SA, Daramola MO (2023) Embracing the future of circular bio-enabled economy: Unveiling the prospects of microbial fuel cells in achieving true sustainable energy. *Environ Sci Pollut Res* 30:90547–90573. <https://doi.org/10.1007/s11356-023-28717-0>.
80. Wu Q, Liu J, Li Q, Mo W, Wan R, Peng S (2022) Effect of electrode distances on remediation of eutrophic water and sediment by sediment microbial fuel cell coupled floating beds. *Int J Environ Res Public Health* 19:10423. <https://doi.org/10.3390/ijerph191610423>.
81. Yaqoob AA, Khatoon A, Mohd Setapar SH, Umar K, Parveen T, Mohamad Ibrahim MN et al. (2020) Outlook on the role of microbial fuel cells in remediation of environmental

pollutants with electricity generation. *Catalysts* 10:819.
<https://doi.org/10.3390/catal10080819>.

82. Zhao C, Song Y, Chen H, Li Y, Lei A, Wu Q, He Q (2025) Study on the selective regulation of microbial community structure in microbial fuel cells by magnetic field–coupled magnetic carbon dots. *Bioresour Technol* 437:130565.
<https://doi.org/10.1016/j.biortech.2025.130565>.

83. Zhou Y, Chen Y, Yang J, Xiao L, Jiang L, Wang X, Tang Y (2023) Insight into the enhancing mechanism of exogenous electron mediators on biological denitrification in microbial electrolytic cell. *Sci Total Environ* 896:165096.
<https://doi.org/10.1016/j.scitotenv.2023.165096>.



DELHI TECHNOLOGICAL UNIVERSITY

(Formerly Delhi College of Engineering)

Shahbad Daultapur, Main Bawana Road, Delhi-42

PLAGIARISM VERIFICATION

Title of the Thesis: “Electrophoretic Induction of Native Microbial Biofilms for Eutrophic Water Remediation and Prospective Bioelectrochemical Applications”

Total Pages: 70

Name of the Scholar: Simran Kumari (24/MSCBIO/20).

Supervisor: Prof. Jai Gopal Sharma, Department of Biotechnology

This is to report that the above thesis was scanned for similarity detection.

Process and outcome is given below:

Software used: Turnitin, **Similarity Index:** 4%, **AI:** 0% **Total Word Count:** 12100

Date: 25/05/2026

Candidate's Signature

Signature of Supervisor

ORIGINALITY REPORT

4% SIMILARITY INDEX	2% INTERNET SOURCES	3% PUBLICATIONS	1% STUDENT PAPERS
-------------------------------	-------------------------------	---------------------------	-----------------------------

PRIMARY SOURCES

1	www.mdpi.com Internet Source	1%
2	batadora.trentu.ca Internet Source	<1%
3	www.researchgate.net Internet Source	<1%
4	"Microbial Fuel Cell", Springer Science and Business Media LLC, 2018 Publication	<1%
5	Ashwani Kumar, Sivasakthivel Thangavel, Gaurav Dwivedi. "Green Hydrogen Production - Storage, Transportation and Applications", CRC Press, 2025 Publication	<1%
6	pmc.ncbi.nlm.nih.gov Internet Source	<1%
7	Lavanya Addagada, Mukesh Goel, Muhammad Kashif Shahid, Sundramurthy Venkatesa Prabhu et al. "Tricks and tracks in resource recovery from wastewater using bio-electrochemical systems (BES): A systematic review on recent advancements and future directions", Journal of Water Process Engineering, 2023 Publication	<1%
8	assets-eu.researchsquare.com Internet Source	<1%

9	Boya Sun, Peijing Kuang, Yubo Cui, Yuesuo Yang, Changhong Zheng. "Simultaneous nitrification and denitrification microbial fuel cells (SND-MFC) for nitrogen removal and bioelectricity recovery: a review of	<1%
----------	--	---------------

0% detected as AI

The percentage indicates the combined amount of likely AI-generated text as well as likely AI-generated text that was also likely AI-paraphrased.

Caution: Review required.

It is essential to understand the limitations of AI detection before making decisions about a student's work. We encourage you to learn more about Turnitin's AI detection capabilities before using the tool.

0 AI-generated only **0%**
Likely AI-generated text from a large-language model.

0 AI-generated text that was AI-paraphrased **0%**
Likely AI-generated text that was likely revised using an AI-paraphrase tool or word spinner.

Disclaimer

Our AI writing assessment is designed to help educators identify text that might be prepared by a generative AI tool. Our AI writing assessment may not always be accurate (i.e., our AI models may produce either false positive results or false negative results), so it should not be used as the sole basis for adverse actions against a student. It takes further scrutiny and human judgment in conjunction with an organization's application of its specific academic policies to determine whether any academic misconduct has occurred.

List of Publications with Acceptance letters and certificates

International Conference on Biosciences Beyond Boundaries: Healthcare, Bio-Economy & Sustainable Well-being



A review paper entitled “**Converging Native Microbial Consortia in Bioelectrochemical Systems for Eutrophic Water Remediation and Energy Recovery: A Systematic Review**” is currently under revision stage

Ref: Submission ID 5c921eb5-05bf-45db-921c-4049dbdd6496

Deadline: 21 May 2026

Dear Dr Sharma,

Your manuscript, "Native Microbial Consortia in Bioelectrochemical Systems for Eutrophic Water Remediation and Energy Recovery", has now been assessed.

We invite you to revise your paper, carefully addressing the comments from the reviewers and the editor. Please ensure the results are accurately reported, any overstated conclusions are rewritten and the limitations of the work fully explained. When your revision is ready, please submit the updated manuscript and a point-by-point response. This will help us move to a swift decision.

We recommend submitting all revisions within the mentioned deadline.

If you need more time, please contact us and include your submission ID.

Kind regards,

Vassilios Tsihrintzis
Editor
Environmental Processes

A review paper entitled “**Mannan-Rich Fractions in Poultry Nutrition: Sustainable and Defensive Strategy against Antimicrobial Resistance**” has been accepted for publication in “Recent Trends in Infectious Diseases.”



Recent Trends in Infectious Diseases
ISSN: 3048-9857
SJIF- 3.104
Acceptance Letter



Dear Author,

Congratulations on the acceptance of article “**Mannan-Rich Fractions in Poultry Nutrition: A Sustainable and Defensive Strategy against Antimicrobial Resistance**” for publication in **Recent Trends in Infectious Diseases**. This letter serves as our formal acceptance of your paper. We affirm that your paper has met the Journal’s Peer Reviewed publication criteria.

Your diligent efforts and commitment have yielded success, and we are privileged to publish your work. The Journal’s editorial team has conducted a comprehensive review of your manuscript, and we believe it will add significant value to the field of Medical Science.

Author Name: Simran Kumari, Priyanka Parmar, Jai Gopal Sharma*

Manuscript Title: Mannan-Rich Fractions in Poultry Nutrition: A Sustainable and Defensive Strategy against Antimicrobial Resistance

Received Date: 31st March 2026

Accepted Date: 11th April 2026

Thank you very much for submitting your article.

With Best Regards,
Prof. Ibrahim F. El-Bayomy
Editor in Chief
Recent Trends in Infectious Diseases





STM Journals, A Division of Consortium e-Learning Network Pvt. Ltd.
Editorial office: A-118, 1st Floor Sec-63 Noida - 201301 (U.P.) India
Regd. Office: - Office No. 4, First Floor, CSC Pocket -E Market, Mayur Vihar, Phase-II, New Delhi-110091
www.celnet.in, www.stmjournals.com, www.mhajournals.in, www.stmconferences.com
E-mail: info@celnet.in Tel.: 0120 - 4781200/204/206/211