

**DESIGN AND OPTIMIZATION OF FINS FOR HEAT TRANSFER
ENHANCEMENT USING ANSYS**

A Dissertation submitted to the Delhi Technological University, Delhi in fulfillment of the requirements for the award of the degree

Master in Technology
In
Mechanical (Thermal) Engineering
By
SANCHIT CHAUDHARY
(2K19/THE/09)

Under the supervision of
Dr. NAUSHAD AHMAD ANSARI



Mechanical Engineering Department

Delhi Technological University

Shahbad Daulapur Bawana Road

Delhi – 110042, India

June 2022

ABSTRACT

One of the most important engine components that is subjected to extreme temperature changes and thermal strains is the engine cylinder. Fins are put on the cylinder's surface to increase the rate of convection heat transfer. The current study looks at how pin fins that are unique shaped (circular, conical draught pin fin) and fitted with cylindrical cross-sectional to increase the variation in the heat exchange rate may improve heat dissipation and pressure drop across a flat surface. Heat sinks are used in heat dissipation applications. Heat sinks that have been around for a long time are typically insufficient to keep newer, hotter working components cool. Blades, for example, have larger surfaces that aid in heat dissipation. Holes in the fins help speed up the rate of heat dissipation. Because it is exposed to high temperatures and heat stress, the engine chamber is a crucial component of the engine. The particles are dispersed around the cylinder surface to increase the quantity of convective heat exchange. When fuel is consumed in a motor, heat is produced. Friction between moving components is a common source of extra heat. Expanded surfaces called fins are put on the perimeter of motor cylinders in an air-cooled I.C engine to increase heat transmission. As a result, fin analysis is critical for improving heat transfer rates. The major goal of this research is to look at previous studies that looked at changing the shape and material of the cylinder fin in order to improve the cooling fine heat transfer rate. Temperature changes of fins created across four geometries (plate fins, circular pins, holes, and pipe fins) were assessed and authorized using ANSYS software, as well as a clear state heat exchange research. The trials were carried out to examine whether the fins had any temperature changes. Fine performance models are assessed in Ansys using experimentally produced heat flow and temperature changes, and FEM is utilized to identify temperature variations in various fine models in the field. The goal of this research is to enhance the rate of heat dissipation by using wind movement. The research's major goal is to increase thermal characteristics by modifying shape, material, and fine design.

TABLE OF CONTENTS

	Page No.
ABSTRACT	i
TABLE OF CONTENTS	ii
LIST OF TABLES	iv
LIST OF FIGURES	v
CHAPTER 1	2
INTRODUCTION	2
1.1. Introduction.....	2
1.2. Heat Transfer	3
1.3. Extended Surface (Fins).....	3
1.4. Significant Parameters in Study of Fins.....	5
1.4.1 Length of Fin.....	5
1.4.2 Fin Material.....	5
1.4.3 Fin Cross Section	5
1.4.4 Fin Pitch and Thickness	5
1.4.5 Heat Transfer Coefficient	6
1.5. Applications of Heat Sinks (Fins).....	6
1.6. Objective of thesis.....	7
1.7. Scopes of the Project.....	7
1.8. Organization of Thesis	8
CHAPTER 2	10
LITERATURE REVIEW	10
2.1. Introduction.....	10
3.1. Introduction to FEM	21
3.2. Procedures for the Finite Element Method	21
3.3. Convergence uses.....	23
3.4. Advantages of FEM	23
3.5. Limitations in FEM.....	23
3.6. Applications of FEM.....	24
3.7. Procedure for ANSYS analysis.....	24
3.8. Material properties	25
3.9. Find the solution	25

3.9.1. Pre – Processor.....	25
CHAPTER 4.....	30
DESIGN AND ANALYSIS OF FINS MODEL	30
4.1. General.....	30
4.2. Thermal Analysis of Fins Model in Ansys	30
4.3. Modeling of Fins.....	32
4.4. Material Properties.....	33
4.5. Applying boundary conditions.....	34
CHAPTER 5.....	38
RESULTS AND DISCUSSION	38
5.1 Introduction.....	38
5.2. Results and Discussion	38
CHAPTER 6.....	50
CONCLUSION	50
6.1. Conclusion	50
6.2. Future Scope	51
REFERENCES.....	53

LIST OF TABLES

Table No.	Table Description	Page no.
4.1	Dimensions of Fins Model	32
4.2	Material properties of Fins Model	34
4.3	Boundary conditions of Fin model	34
5.1	Shows the Maximum and Minimum temperature variations	43
5.2	Heat Flux Found on All conditions of Fin Models	47

LIST OF FIGURES

Figure No.	Figure Description	Page no.
1.1	Experiment explaining heat transfer by conduction	10
1.2	Natural convection process	11
1.3	Forced Convection	12
1.4	Transmission of Radiation	13
1.5	diagram of heat transfer fin	14
1.6	Use of extended surface or fin to enhance heat transfer	14
4.1	Plate Fins Designed Model in Ansys	31
4.2	Circular Perforation in plate fins designed Model in Ansys	31
4.3	Circular pin fins designed Model in Ansys	31
4.4	Conical Draft pin fins designed Model in Ansys	32
4.5	Meshed Model of Fins without holes	32
4.6	Meshed Model of Fins with Circular holes	33
4.7	Meshed Model of Fins with Rectangular holes	33
4.8	Applied Boundary conditions on Plate Fins	35
4.9	Boundary constraints applied to plate fins with circular holes	35
4.10	Applied Boundary conditions on Circular Pin Fins	36
4.11	Applied Boundary conditions on Draft Pin Fins	36
5.1	Temperature Distribution of Plate Fins	39
5.2	Temperature Distribution of Rectangular plate Fins with holes	40
5.3	Temperature Distribution of Circular Pin Fins	40
5.4	Temperature Distribution of draft conical Pin Fins	41
5.5	Heat Flux and Stress of Plate Fins	41
5.6	Heat flux of Rectangular plate Fins with holes	42
5.7	Heat flux and Stress of Circular Pin Fins	42
5.8	Heat flux and Stress of Circular Pin Fins	43
5.9	Temperature drop in simple plate fins model	44
5.10	Temperature drop in plate fins with holes model	44
5.11	Temperature drop in circular pin fins model	45
5.12	Temperature drop in conical draft pin fins model	45
5.13	Comparison of Temperature drop in all fins model	46

5.14	Maximum and Minimum Temperature found on Fin Models	46
5.15	Total Temperature drop variations in Fin Models	47
5.16	Comparison of Heat flux of Fin Models	48
5.17	Comparison of Thermal Stresses of Fin Models	48
5.18	Engine cylinder Designed model in SolidWorks	49
5.19	Engine cylinder model with fins in Ansys	50
5.20	Temperature variations in Engine cylinder model with fins using AL6082	50
5.21	Temperature variations in Engine cylinder model with fins using AL1060	51

CHAPTER 1
INTRODUCTION

CHAPTER 1

INTRODUCTION

1.1. Introduction

Basically, the running of vehicles depends on the performance of engine. Currently, many industries facing problem of overheating in machine components due to heat generation within them. The manufacture made the appliances with compact design and low cost. But the heat needs to be transfer at higher rate to maintain the temperature of the machine components so that the component temperature remains within working temperature range. To overcome the problem of overheating, especially in thermal systems, fins are usually provided. Fins can be analyzed in design phase only using Computational Fluid Dynamics as tool and assuming uniform heat transfer coefficient model on its surface. Thermal inspection is a piece of material science which questions the properties of materials which undergo thermal inspection and which are subject to temperature change in addition. Heat transfer through structures such como internal ignition engines, moulding blocks and other applications is studied by thermal analysis in conduction and convection modes during heat exchange. [1]

Thermal structures must be developed and assessed to produce and dissipate a suitable amount of unwanted heat while maintaining the needed interest. Thermal hardware's efficiency is determined by a variety of elements, the most important of which is the cooling or heating of its constituent components. The problem comes when the heat transferred by these fins is insufficient to cool the heat-producing devices, resulting in component damage. The main purpose of the work is to enhance heat exchange rate by improving the thermal properties of fins using various geometric patterns.[1-2]

The study's major goal is to improve the heat transfer rate of fins, which may be accomplished by changing specific parameters and shape. Fins are often explored by assuming a surface with a uniform heat exchange coefficient design. Different studies' optimizations revealed that it isn't constant, but changes throughout the fin length. It is a direct outcome of the fluid flow in the between fin region being obstructed in a non-uniform manner. The rate of heat dissipation increases as the heat exchange zone is expanded, while the rate of heat exchange decreases as the resistance to fluid flow increases. The needed heat sink should always be greater than devices if the final

objective is to dissipate heat from high heat flux densities. As a result, the heat sink's execution is reduced. The resistance of the inner fins might be lowered by inserting notches or adding perforation to the fins. The addition of a cross-fin in the middle increases the heat transmission area, but it also creates a stagnant layer of hot air near the fin base. Adding holes to the fins may improve the fluid flow movement on the bottom of the display.[3]

1.2. Heat Transfer

In thermodynamics, thermal exchange from a heated body to a colder body is the exchange of thermal energy. If a protest or liquid, compared with the surrounding environment or another body, is at a different temperature, heat exchange is otherwise referred as heat exchange. Heat flow occurs up to a similar temperature in the body and environment. According to law 2 of thermodynamics, the heat exchange between objects can never be stopped if there's a temperature difference between items in proximity. The energy current is defined as heat because of fluctuations in temperature, and the heat exchange analysis controls the rate of exchange of such energy. The transfer of heat from a heated body into a colder body is the transfer of thermal energy.[3] Heat exchange happens up to the same temperature in the body and the environment. The second law of thermodynamics asserts that heat transfer cannot be prevented when there is a temperature difference between entities that are in close proximity. As the temperature differential between two systems increases in transit, so does the amount of heat. Because of the small temperature differential between the frames, the heat exchange process is irreversible and the heat stream cannot be reversed.[4-5]

1.3. Extended Surface (Fins)

With the inclusion of a fin, heat may be transported more readily from or to the surrounding convection. The bigger the temperature difference between the item and the atmosphere, or the greater the surface area of the component, the greater the convective heat transfer coefficient, or the greater the thermal discharge. Frequently, funds are inadequate, or there are no other feasible solutions. Adding a fin to the item, on the other hand, increases the surface area and improves the heat transfer rate. In engineering programmes, fins of unique forms and lengths are employed to promote heat transfer.[6]

- rectangular fin
- Triangular fin
- trapezium fins
- circular segmental fins.

Fins are used to accelerate the heat transfer rate from surfaces in a range of engineering applications. Typically, the fin is constructed up of a combination of metals with good heat conductivity. The fins are open contacts with a flowing liquid that cools or heat the body, and their high thermal conductivity allows for increased heat exchange from the body's mass via the blade. Cooling balances come in a range of shapes and sizes, and they're employed in a number of applications.

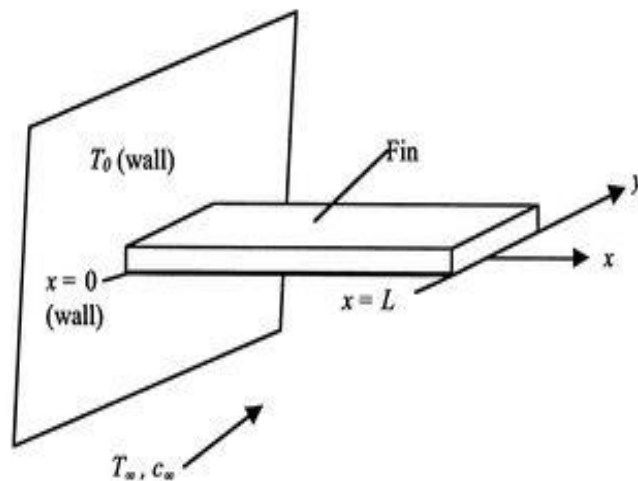

Figure 1.5: fin model [27]

(Source: HMT. Revised edition, R. K. Rajput).

Heat transfer explains the thermal energy trading through heat dissipation between physical systems that rely on the weight and the temperature. The most common means of exchanging heat are conduction, convection, and radiation. expect the territory an at models of various fins appeared in Figure 1.6 where warm is being exchanged from the surface at a settled temperature T_s to the encompassing liquid at a temperature T_∞ with a thermal exchange coefficient h . By increasing the convection coefficient h , lowering the liquid temperature T , or adding materials to the region A, the heat exchange rate can be expanded.[7]

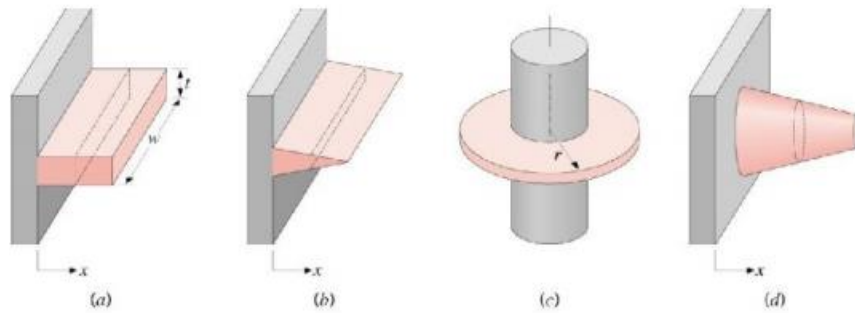

Figure 1.6: Increased heat transmission by the use of a larger surface area or fin [27]

1.4. Significant Parameters in Study of Fins

The various significant factors in study of fins are, [10]

- length of Fin
- Material of Fin (Conductivity)
- Cross section of Fin
- Pitch of Fin
- Thicknesses of Fin
- Heat transfer coefficient
- Effectiveness and efficiency of Fin

1.4.1 Length of Fin

If the fin length increases, the temperature of the fin decreases. Long fin length is normally not due to a lack of fine quality for long fine, so shorter fines are used. [10]

1.4.2 Fin Material

Fine processing requires materials with high thermal conductivity, power, and light weight.

1.4.3 Fin Cross Section

The cross-section of the fin is critical in heat transmission, and the finish-sectional transformation has changed significantly as the fin's surface area has changed.

1.4.4 Fin Pitch and Thickness

Transmission speeds are improved by reducing fine thickness; nevertheless, a minimum thickness of 2.5 mm is limited by the need for fin strength and the output cap for engine fin purposes. The heat transfer rate's fin pitch is also noticeable. When the fining point increases, the sum of fines per unit region declines, reducing thermal area and, finally, the intensity of heat transfer, and vice versa if the pitches vary. According to the literature, a

distinct pitch value was defined for both free convection and force convection for a special shape for both free convection and force convection. [10-11]

1.4.5 Heat Transfer Coefficient

The coefficient of heat transfer is described as heat which is transferred through the unit surface during the unit temperature differential. HTC relies on its importance [12]

- Thermal properties
- Types of flow
- Fluid properties
- Surface geometry
- Atmospheric conditions etc.

1.5. Applications of Heat Sinks (Fins)

Natural Convection is the liquid flow prompted by buoyant powers, which emerge from various densities, caused by temperature varieties in the liquid. Low-control device thermal administration has long used natural convection as a heat sink. This cooling strategy has numerous points of interest, for example, the nonattendance of moving parts, of intensity utilization, and of support need. Furthermore, its operation is calm, reliable, and cheap. Therefore natural convection heat transfer plays a major role in many forms of cooling systems, including the computer industry, which has been attracted for decades by constant research. Fig.1.6 demonstrates the normal heat sink applications. Some applications may be mentioned: [10]

- Steam power plant economizers
- Motors and electrical transformers
- Convectors for the heating of hot water and steam
- Engine cylinders that have been air-conditioned, I.C. engines, and air compressors
- Electronic devices'.

1.6. Objective of thesis

In order to succeed, three key goals must be met:

- Using SOLIDWORK software, create the Fins' geometry.
- Using ANSYS software, analyse the best fins model for optimal heat transmission.
- ANSYS software was used to conduct a thermal study to determine the maximum temperature.

1.7. Scopes of the Project

A new scope must be defined in order to explore the Fins models. A investigation of heat dissipation of fins was conducted. This study began with a search for previous research surveys on enlarged surfaces, SOLIDWORK programming, and ANSYS programming. At that point, all Fins-related information will be obtained. Aside from that, the substance that will be employed is aluminum alloy. The other extension is to use SOLIDWORK programming to design the fins and ANSYS programming to investigate them. To get superior results, holes were drilled into the surface of the fins to boost heat transfer rate, and various kinds of perforation were applied to the fins model, followed by a comparison of heat transfer rates across all fins models.

1.8. Organization of Thesis

The following are the chapters that make up this thesis:

CHAPTER-1

This chapter consist of the framework of the research question, explaining the necessity for inexpensive and sustainable uses of fins and the objective of this study.

CHAPTER-2

Heat transmission via extended surfaces is the subject of this chapter, which includes a literature assessment.

CHAPTER-3

This chapter consist of the Methodology of experimental investigation of the Finite Element analysis to investigate properties of heat transfer in fins.

CHAPTER-4

This chapter shows the modelling and design analysis of Fins model using various techniques in Ansys workbench.

CHAPTER-5

This chapter consist of results analysis and discussions on the better heat transfer rate of designed models of fins.

CHAPTER-6

Conclusion consists of the key finding of this investigational analysis as well as possibilities for future work.

CHAPTER 2
LITERATURE REVIEW

CHAPTER 2

LITERATURE REVIEW

2.1. Introduction

Various research carried out in past decade show that heat transfer through fins depend on number of fins, fin pitch, fin design, wind velocity, material and climate conditions. Different literature surveys suggest that variations in the cross-section influence how thermal transfer across extended surfaces and the thermal transfer coefficient.

Dhamyaa S.Khudhur et. al. (2022) The researchers investigated several numerical simulations in three dimensions using a wide range of parameters. The use of numerical simulations allowed for the investigation of two distinct types of straight plate fins: heat sinks with straight plate-add fins and heat sinks with straight plate-subtract fins. Experiments are carried out using three different kinds of turbulent forced convection, with Reynolds numbers ranging from 6300 to 35,120 and heat fluxes ranging from 1194 to 23353 W/m² respectively. The heat transfer coefficient shows a high agreement between numerical simulation and laboratory testing when compared to straight than other shapes of fins. This coefficient shows an increase of approximately (38, 43 percent) for straight with added semicircular and straight with delete semicircular fins, respectively, when compared to straight. In addition, when comparing straight fins with added semicircular fins and straight fins with removed semicircular fins to straight fins compared to other types of fins, the Nusselt number climbs by about (21 percent and 32 percent).

Abhay Bele et. al. (2022) To examine several research articles pertaining to the thermal analysis of extended surfaces or projections of materials on the system (engine) known as fins in air-cooled IC engines. The fins improve the heat transfer area and hence the rate of heat transfer from the system to the environment. Convection cooling is used to cool different buildings using fins. The design of the system, in general, limits heat transmission via fins. The heat transfer impact may be altered by utilizing various materials with varying thermal conductivities, improving engine design, increasing fin cross section area, employing perforations on fins, and doing thermal analysis on fins. As a result, the purpose of this work is to examine how heat transfer via extended surfaces and the heat transfer coefficient are influenced by altering cross-section. This

research is beneficial in determining better fin design and material for improved engine cooling.

Shankar Durgam et. al. (2021) The rate of heat transmission via fins made of various materials was investigated in this study. Fin geometries affixed to the cylinder block, such as rectangular fins. Different physical and thermal qualities, as well as the cost of fin materials, are evaluated in this research. CATIA - V5 is used to generate the 3D model of the geometries, and ANSYS FLUENT 2020 R1 is used to study the thermal characteristics. The value of heat flux increased via the cylinder block to the surroundings, according to the findings of a steady state thermal examination of an engine cylinder. The weighted point technique was used to determine fin performance based on the optimal material for fin production.

Charan et. al. (2018) has analyzed expanded surfaces that are often used in a broad range of engineering applications to improve convection heat transfer. To improve heat transmission, holes may be added to the lateral surface of the heat exchanger fins. From the research, it is evident that tip temperature is least for aluminum triangularly perforated with three perforations in it and h increase is highest for triangularly perforated with three perforations of aluminum material. The above research has shown that when compared to non-perforated fine the convective heat transfer coefficient is increased for perforated fine, then that the numbers for perforated fine are increasing compared to non-perforated fine. Therefore, a three-sided aluminum triangle is best suited to finish applications.

Sangaj et. al. (2018) Experimental research to determine the thermal distribution of various materials and geometries within the pin fine, the state heat transfer analysis was carried out with the software ANSYS for the testing and validation of outputs using a finite element. The main objective of the work is to optimize thermal properties through various geometries, materials and fine thicknesses. Different parameters (shape, geometry, material) were compared for the pin-fin function. In contrast, the various form and material types are picked. In two cases it is found that copper hollow circular pin-fin and copper rectangular pin-fin are the better pin-fin, but because of economical constraints and findings in, copper and aluminum fines with a similar appearance have almost the same heat transfer levels.

Beldar et. al. (2017) CFD software was used to perform steady state thermal analysis. Analysis of air flow, pressure drop analysis. The heat input varies by 10%, 20% and 30% by 25 Watts, 45 Watt and 65 Watts. The heat is different. In the sector, a fin array not being compensated, even though the heat transfer region decreases. After an entry on the middle part of the small, natural air flow decreases, the air velocity increases over the channel, the air pressure rises across the channel, the air temperature in the cylindrical heat sink increases. Using experimental and CFD tests it found that the optimum height transition relative to the other end range is 20 percent of the rectangle notch scale of the longitudinal fine.

Rajesh et. al. (2017) Variations in shape and material have been used to examine the fine's thermal characteristics and the thickness of the cylinder fines (Cu and Al alloy 6082). Fins models are formed by altering the circular geometry and the fine thickness of both geometries. Pro / Engineer & Unigraphics are the 3D modeling software used. Cylinder fins are analyzed thermally to determine the temperature variation distribution over time. The analyzes are done with ANSYS. With thermal analysis on the fins of the engine cylinders, the heat dissipation inside the cylinders is beneficial. The theory used in this paper is the use of the invisible working liquid to maximize heat dissipation by air.

Jain et. al. (2017) Heat dissipation of fins was analyzed by changing their geometry. Parametric fine models to forecast the transient thermal behaviour have been developed. There are different geometries including rectangular, circular, triangular, and extensive fines after models are made. CREO Parametric 2.0 is the simulation framework used. ANSYS 14.5 is used to analyze this. Current material is usually Aluminum Alloy 204, the thermal conductivity of which is 110-150W / m-°C. Analyzes were carried out with aluminum alloy 6061, which is about 160-170W / m-oC heat conductivity higher. After the material has been determined, By altering geometric factors such cross-sectional area, parameter, length, thickness and so on, the heat transfer rate was increased in the third phase.

Kummitha et. al. (2017) Research carried out to determine the best material that ensures the highest heat transfer rate during the combustion processes keep the motor

in secure operation and with high strength, low weight. A passion pro bike cylinder block was considered and based on GAMBIT software as well as thermal analysis with ANSYS software. A variety of aluminum alloys have also been tested and all tests have been evaluated for the best results. It was concluded that the A480, with the above temperature contours and column schemes, had better heat transfer rate as well as greater strength compared to other considered alloys.

Ravikumar et. al. (2017) Experimented with geometric variables to improve thermal performance and the design of the heat sink. This project used thermal testing to identify a cooling solution for a 5W CPU desktop. The design enabled the chassis to be cooled with heat sink attached to the CPU to properly cool the entire system. This study considered the configuration of cylinder pin circular fins and rectangular heat sinking fins with aluminum base plating and the regulation of processes for the CPU heat sink. The heat dissipation was further enhanced by an alternative model of thermal fins. In a constant and temporary thermal analysis, the existing materials and the proposed materials were analyzed for comparison in ANSYS. Rectangular, circular pin fine heat sinks were examined for the cooling efficiency of the CPU device chassis. The difference in the heat sink temperature was correlation.

Sandeep Kumar et. al. (2017) The rate of heat transfer in the heating area IC engine was studied. For this transient thermal study, the actual design of the Bajaj discovers 125 CC single cylinders was carried out. Thermal transient analysis was conducted to optimize geometry parameters and boost heat transfer from the IC engine to ensure that the engine cylinder configuration was actual and proposed. The result showed that the proposed design provides a greater efficiency and heat transfer rate from the IC engine heating field. It was proposed that old design would be replaced by new design.

Mogaji et. al. (2017) calculated the heat flow across a rectangular fin's surface area with and without taking radiation heat loss into account in the numerical analysis. Physical characteristics such as fin length, thickness, metal type, and emissivity,, were compared to see how they affected the fin's thermal performance. The rate of heat dissipation was shown to be greater for fins with thermal radiation than for those without, regardless of the metal type of fin investigated. Stainless steel, aluminium, and copper all have underrated fin thermal performance when thermal radiation is excluded,

with underratings ranging from 15.6% to 21.5% to 21.8 percent in each instance. In comparison to stainless steel, aluminium and copper had superior heat transfer improvement in the fin thermal performance.

Arefin (2016) For the Pin Fin heat sink, which stretches the pins outward, a new pin design was implemented. The processes then are completed, provided that the conditions are stable, with the thermometric study of natural convection for the circular shape in the line and a medicated pin fine heating sink. The heat sink is superior than the ordinary pin fine heat sink in terms of efficiency. The finite-element approach is employed for this computational thermal analysis of solid work. Using a computer simulation, a new heat sink pin fin model has been developed. It has also been developed for comparison the typical model for the pin fin heat sink. Thermography was used to determine the source of the problem and the standard model was compared successfully with the updated model.

Balendra et. al. (2016) verified the rectangular unnotched fin by doing experimental research and simulations for a variety of thermal loads. Before moving on to the next step, they created a number of distinct inverted notched fins based on various shapes and sizes of constant area. In all instances, the heat transfer coefficient rose continually, but the greatest heat transfer rate was achieved with an inverted triangular notched fin. It was found that the heat transmission coefficient of an inverted trapezoidal notched fin was $6.08 \text{ W/m}^2\text{k}$, whereas the heat transfer of an inverted rectangular notched fin was 5.67 W/m^2 . As compared to a rectangular unnotched fin, the heat transfer rate of an inverted triangular notched fin has risen by about 50.51 percent.

Kongre et. al. (2016) Temperature distribution was measured using the ANSYS working bench by various geometry and cylinder fin thickness. Experimentally, it is observed that the number of Nusselt solids and perforated fins increases, as does the number of Reynolds. with a rise in the number. Also, square drilled drills for the same size improve the efficiency of square holes slightly more than circular. Thus, while attempts to modify several parameters for fin for HT increase are made, there is still a vast scope for modification of finishing design.

L. Natrayan et. al. (2016) Ansys work bench was used to investigate the thermal characteristics of various cylinder fin geometries. When it came time to generate the 3D models, the geometries were built in SOLIDWORKS 2016, and their thermal characteristics were examined in Ansys workbench R 2016. The temporal change in temperature distribution is of relevance in various applications, such as cooling. Critical design parameters for improved life can be established through the precise thermal simulation. The cylinder fin body is made of aluminium alloy AA 6061, which has a thermal conductivity of 160–170 W / mk.

Laad et. al. (2016) Conducted optimization processes with ANSYS Workbench 14.0 simulations. The heat transfer was taken as a pin-finishing material in natural air and aluminum 6063. The different heat sink velocities 5, 10 & 12 m / s were taken to examine the thermal performance of the various profile ends. Different temperatures of 15 W, 20 W & 25 W were simulation, and 295 K were used for the air intake temperature. The goal of this research was to study the effects of the different pin-fins design configurations. The heat sink design with circular pins achieves the best cooling, according to the results. After picking an effective heat sink through CFD simulations, the constant thermal efficiency of a circular pin heat sink at various fin heights was determined. The results revealed a drop in finish height in temperature.

Pathak et. al. (2016) has taken 3 different shapes of geometry- circular, square, taper which were modeled and analyzed in SOLID WORKS 2015. The objective of this paper was to observe and analyses the heat dissipation of different material with respect to different geometry. A comparison has been shown between two different materials- Alloy Steel and Aluminum alloy 1060. It is stated that Alloy steel is quite better than aluminum alloy because of the large temperature difference and can be better replacement. Also, temperature difference varies with the geometry and taper fin showed large temperature difference among other geometry. So, it is concluded that Tapper fin of alloy steel should be used for better heat dissipation.

AL Shabbani et. al. (2015) The cylindrical fins model of CFD, implemented by ANSYS Multiphysics software, has been tested. Steel was the material used to this end. The partial differentiation is transformed directly into regular differential equations in this analysis. The experimental results were found to be compatible with the analytical

results obtained. The temperature distribution falls on all different surfaces monotonously along Coordinate X. The more heat convection on the lateral surface and the more effectively thermal energy is carried through the surface to the atmosphere, also results in heat transfer rate hitting early invariant time.

Prabisha et. al. (2015) Development and research by modeling and analysis of a redesign by simulation software a heat sinks thermal analysis of existing fin surfaces conducted an investigation to provide optimal development for the heat sink. In addition, technical programming has been used to obtain the efficiency and effectiveness of the heat sink. Mathematical calculations. The efficiency of the heat sink was analyzed and compared under the same working and operating conditions. The result was stronger and less weighty than the present model. This was an advantage because the cost could be reduced. The best effect was seen through simulation in a tapered heat sink at much higher dissipation rates. Compared with the base model, the efficiency and fineness of the corrugated and tuned heat sink are high. Therefore, more research work could be carried out through different heat flows and the consideration of other thermal parameters for study was suggested.

Kansal et. al. (2015) Comparative study was performed for the heat sink with fins of different profiles: rectangulum, trapezoidal, interrupted, rectangular, circular and staggered heat sinks as heat sinks are typical devices used in electronic components to improve heat transfer. A new concept was suggested in this work for cooling electronic parts using the heat sink for aluminum alloy. A number of geometrical parameters, such as a fine length, fin thickness, number of fines, the thickness of the base plate, space of fine form, profile and the material, etc., are required to select the optimal heat sink. The results showed that the design of the heat sink with circular pins was optimum cooling. These heat sink designs can provide cooler electronic circuits and reduce cost by reducing material than regular heat sinks.

Oswal et. al. (2015) Different factors that influence fins thermal performance have been studied. Factors were examined in the design of a pin fin array. Their performance on the arrays such as maximum temperature, pressure and speed was comparatively investigated by changing different parameters. The best solution was suggested based on the results obtained. Copper pin fins, which were 43,8775 0C, are more appropriate for obtaining the minimum temperature at the heat sink. Because copper is expensive,

you can choose a less expensive and lighter option, such as an aluminum heat sink, which can withstand temperatures of up to 50.96310C. The Plate Fin heat sink, which has the lowest pressure drop, was, nonetheless, suggested for the lowest pressure drop. **Shrivastava et. al. (2015)** Analyzed fine engine block thermal analysis. By conducting thermal analysis on cylinder block perfect, the thermal dissipation within the cylinder was beneficial. The principle behind the cylinder bloc cooling was to extend the fins across the cylinder block, which would increase the heat transfer rate. In Solid Works 3D software the parametric model of engine block fins has been developed, and thermal analysis has been done for fine-tuning and the block to determine temperature variations with time and in constant state. ANSYS software was used for the thermal analysis. Different materials were also analyzed. The design was modified and two models were created. Both models have been evaluated and compared.

Patel et. al. (2014) Thermal properties analyzed by varying geometry, material and cylinder fins thickness. Temporary temperature analysis and other thermal quantities that differ over time have been performed. In many applications, such as in cooling, variations in temperature distribution over time were found to be of interest. Critical design parameters can be identified for enhanced life through precise thermal simulation. Maximum analyzes of 12 different cases were covered in two major 3.5 and 4.0 mm thickness classes. The ambient temperature variable in each case was 25, 40 and 50 degrees c. The safe motorcycle operating speed was 50 km per hr. However, the same performance was also studied at lower environmental temperatures such as 40 ° C and 25 ° C. Each case was basically evaluated at 50 ° C. For ambient temperatures of 25 degrees C and 40 degrees C were the best results found.

Rairker et. al. (2014) The heat transfer effect for various fluid mass flow rate was studied by the thermal heater exchanger and tube type. ANSYS program has been investigating the thermal stresses induced by fine and tube at a steady stage by adjusting fine width and tube diameter. The measurements have been taken at the different temperatures experimentally by changing the mass fluid rate. Theoretically and experimentally observed findings were compared. The thermal stresses on the fin were also increased as the width of the fin increased. Likewise, different stress values are obtained for the tube by varying tube diameters. Maximum thermal stresses on the fine as well as the tube were observed at maximum valve position.

Chaitanya et. al. (2014) The thermal properties were analyzed using the ANSYS workbench using different geometry, materials and the cylinder fins thickness. The temperature and other thermal quantities that differ over time are calculated by transient thermal analysis. In many applications like refrigeration, the variation in temperature distribution over time was of interest. The precise thermal simulation could help you find important design parameters that will last for a long time. In order to make the body of the cylinder fin, aluminum alloy A204 is used. This alloy has a thermal conductivity of 110-150 W/mk. It and aluminum alloy 6061, which have better thermal conductivities, were used to make cylindrical fins.

Chakraborty et. al. (2014) The semi circular fin efficiency was investigated in consideration of the temperature-dependent thermal conductivity of the fine material as well as the coefficient of heat transfer for heat dissipation of the finished surface. Depending on whether the end number was a few more or more and the tube was small or large, the efficiency of a particular tube size increased. The efficiency range for aluminum was 0.2875–0.311, and copper was 0.295–0.308, with tube size ranging between 0.01 m and 0.09 m and fin numbers between 4 to 24. The efficiency of finishing was shown to increase as base temperature was improved and the environmental temperature decreased. For both copper and aluminum as fine material, the above findings were coherent.

Chavan et. al. (2013) Thermal optimization of pin fin results, the primary objective of this study was for a selection of different materials and geometries to identify the most efficient finish. Tests for different Reynolds numbers have been conducted and results have been identified for each end respectively. The finish was fixed in a block with a diameter of 48 mm and a length of 50 mm. The block was internally threaded while the fin was externally threaded at one end, so it was easy to remove and fit various fins. On the block was fitted the Nichrome wire heater. The results show that the efficiency and efficiency of the pin fin decreased with the increase in the number of Reynolds. Aluminum is the most effective material while the material is wise.

Torabi et. al. (2013) In a straight fin, thickness-shift and variable heat conductivity losing heat through the convection and radiation convection were studied thermal transfer. The calculations were made using DTM for various types of differential

equations. This method could be used. The findings from DTM have been tested for the accuracy of the proposed method using a numerical solution. The present paper focuses on the performance analysis of convective-radiated thermal conductivity step fins. The fin is divided into two parts as thin and thick sections since the thickness of the fin changes gradual. The Differential Transformation Method (DTM), which resulted in two nonlinear heat transmission equations with nonlinear boundary conditions. As the effects of radiation and convection increase, the fin temperature is reduced.

CHAPTER 3
FINITE ELEMENT METHOD

CHAPTER 3

FINITE ELEMENT METHOD

3.1. Introduction to FEM

Finite component techniques may be used to find numerical solutions to a broad variety of technical challenges, including but not limited to The process may be used to any material, regardless of its limits or load situations, regardless of how complicated the shape or geometry is. The estimate of complicated technical structures and structures that do not offer closed-form solutions for equilibrium problems accounts for 15% of the time spent on finite elements. Designers who want to experiment with alternative layouts may do so using a parametric design tool, which isn't exactly environmentally friendly (single shapes, items, loads, and so forth).

It was first developed for use in the aerospace industry to analyse the strain in a complex aircraft construction. It has grown up and evolved into a technique in the field of aircraft design matrix evaluation. It has received considerable praise from academics and practitioners alike for its innovative approach. If you've ever desired to break down an item into its constituent elements, finite element technology may assist you in accomplishing that goal with relative ease. In order to create the final set of nodes, it is necessary to take the structure into mind.

3.2. Procedures for the Finite Element Method

The original design is regarded a mixture of the components linked to a wide range of connections known as nodal factors or nodals, and the finite detail technique is partially split into tiny finite factors called finite elements. Part by part is how the finite detail technique works. A simple function is used inside the field variable version to make it look more like the real thing because it doesn't know things like displacement, pressure, temperature, speed, or speed of a spectrum. Interpolation models or approximation properties are discussed using node field value phrases. The nodal values of a variable field are generally produced via a field equation that may be expressed as a matrix equation.

The approximating functions display the variable area during assembly of the product when nodal values are measured.

The general problems by the technique of the finite elements are explained step by step.

The step-by-step process can be defined as follows for static structural applications:

Step 1: - Explaining the design model (domain). Subdivision or elemental separation of the final area structure is the first phase in the finite element method.

Step 2: - The right interpolation method was chosen. When a complex structure (field variation) can't be correctly anticipated, we presume that the unknown solution can generate a suitable result inside a component. There must be a clear end result, and specific convergence conditions must be met.

Step 3: - The start of stiffness matrices and load vectors (feature matrices). With the supposed version of displacement, both equilibrium situations and the correct variation control should be applied to the stiffness material..

Step 4: - Assembly of element equations to achieve equilibrium.

The individual matrices of the elements of rigidity and loading vectors must be constructed correctly since the structure consists of a great number of finite elements as

$$[K]\phi = P \dots \dots \dots (1)$$

When [K] is denoted a mounted stiffness matrix, age is known as the knot-displacement vector and P is the full shape vector or nodal pressure [K].

Step 5: - To identify nodal displacement values, a system equation solution is needed (subject variable). The limiting constraints of the issue necessitate changing the traditional balancing equations.

The vector ' τ ' can be resolved very problem-free in linear problems. However, the response must be received in a series of ladder, each with the amendment of the [K] and β "or the weight vector P, in the case of non-linear problems.

Step 6:- Detail strains and stresses are calculated. If requested, by utilizing the essential equations of stable or structural mechanics, the detail lines and stresses can be calculated. The phrases in brackets in the above steps apply the overall FEM step by step.

3.3. Convergence uses

A finite definition technique may be used to solve a complex issue numerically. In addition, the solution must be tailored to the specific structure. Because of this, it's possible to project. Because the mesh is finer, the solution will arrive at the proper end result if the stated displacement function is met in three different ways.

- Displacement must have a consistent quality. This problem may be readily solved by using a polynomial displacement model.
- The shift function allows you to represent data in a logical and consistent way. The nodal powers stop at zero since nodes are pushed like rigid frames and the dimension should not be shown. The use of normal sentences in the displacement sentences may usually guarantee that this is the case.
- The output of an element must be kept constant by the moving function. Assuming the problem can be broken down into smaller and smaller bits while keeping its general shape or form. Because of the microscopic scale of these components, dimensions one, two, and three, the stresses in each element frequently involve continuous technical pressures.

3.4. Advantages of FEM

That element has its own characteristics so there is a clear understanding that different material properties can be combined for each element. Nearly all non-homogeneity forms can therefore be incorporated. There is no medium form limit; therefore no problem arbitrary and irregular shapes, since the FEM is based on the concept specification, all numerical approximations. Nonetheless, the technique does not require separate interpolation to expand the approx. solution to every point with the spectrum, as either the variations or the residual form.

One of the main blessings of FEM is that assembled equations are taken from limits. This approach is very smooth and needs no particular generation. The conditions after algebraic equations for finite elements of the entity are recommended instead of each test response to satisfy the limiting conditions.

3.5. Limitations in FEM

FEM as a response reached a very high level of growth, but it is best possible to produce realistic results if primary phenomena can be achieved in coefficient or cloth parameters.

The most repetitive components of FEM use are the primary process by which the spectrum of error free output is subdivided into machine knowledge.

3.6. Applications of FEM

At initially, the finite element approach was used to evaluate aviation systems. The universal character of its approach, on the other hand, makes it applicable to an infinite number of engineering challenges. A limit is a circumstance in which a response is attempted to satisfy the defined limit criteria in a body situation's realm or place.

For evaluating wings, rocket and missile structures, dynamic assessments of random mass responses, and periodic masses, finite details research is a first-class approach. Finite detail techniques may be utilised to effectively handle difficulties like stress sensitivity, stress vessel stress analysis, and dynamic mechanical connection analysis in mechanical design.

When employing finite descriptions, special emphasis is devoted to the balance of concerns in normal or time-independent domains, the Eigenvalue problem, and propagation or short challenges. In balancing concerns for a permanent displacement or strain distribution for a solid mechanic problem, temperature distribution and heat transfer equations may be discovered. frequencies, buckling masses and mode shapes, balancing of laminar fluxes, fluid mechanics involved, and requested resonation characteristics determine Eigen price problems in structural or stable mechanics, while the body's response under time various force is detected for propagation or temporary problems.

Its software in civil engineering is exposed by a finite detailed technique for truss, frame, and bridge static analysis. As a result, the structure can be applied to periodic masses to extract natural frequencies, modes, and structural reactions. In nuclear engineering, the finite element method is used to characterize the static and dynamic structural properties of nuclear vessels, containment structures, and dynamic reaction reactors. Finite techniques are utilized to analyses the influence of heads even in the realm of biomedical engineering. Drilling, subsurface, and dynamic reservoir system studies may all benefit from a finite detailing method.

3.7. Procedure for ANSYS analysis

Static measurement of displacement, stresses, stresses and forces in structures or materials is used because hundreds do not result in significant inertia or damping. In response conditions, stable loading is assumed. Loading types that can be used for a static test include

external forces and loads, regular domestic inertial forces, imposed (non-0) movement speed, temperatures (for thermal stress). A linear or non-linear static analysis may be available. We don't neglect linear static analysis in our current work.

These key steps are the protocol for static analysis:

1. Construction the model.
2. Achieving the solution.
3. Evaluation the results.

A structural examination is carried out using the ANSYS Workbench V.14.0 to carry out the finite element examination of the Fins models during the engine temperature transfer to the air with the aid of fins. At this stage research by the Fins involves a continuous thermal analysis and minor modifications in order to obtain designs. The fins model was built and saved in*.Igs in this file in Solidwork 2016 and imported to the workbench in ANSYS.

3.8. Material properties

For static analysis, Young's modulus (EX) should be illustrated. We define mass residences inclusive of density (DENS) if we intend to apply inert loads (that involve gravity). Similarly, we outline the coefficient of thermal growth (ALPX) if we intend to use thermal centers (temperatures).

3.9. Find the solution

This stage determines the sort of analysis to be performed and the range of possible outcomes. Three levels are required:

- a) Pre – processor step
- b) Solution step
- c) Post-processor step

3.9.1. Pre – Processor

In order to have the same software on a micro, minibus, first-rate and mainframe machine, preprocessor is evolved. It slows down the smooth transition of one computer to another. Preprocessor is an interactive model design for producing and entering information on the FE (Finite Detail) version. The Solution section uses the preprocessor input data and prepares the solution according to the definition of the problem. It creates files in the form of temperature contours on screen and many other contours.

➤ **Geometrical definitions:**

The preprocessor comprises four separate geometric structures, namely key points, lines, areas and volumes. Such structures can be used for geometrical structural representation. All agencies are distinct from other organizations and each has specific labels.

➤ **Model generations:**

Two kinds of techniques are utilized to produce a design:

- a) Direct production.
- b) Solid designing

With strong design, the geometrical limits of the design model can be explained and controls on dimensions and the required element shape can be made and then ANSYS can be started to repeatedly produce all the nodes and fundamentals. Instead of defining these geometries in an ANSYS model, the direct method of development specifies the location of every node and length, type and connections of each unit. However, computerized knowledge of information can be obtained (including FILL, NGEN, EGEN, etc.) Direct technique essentially on numerically designed technique requiring us to retain all node number songs as the finite element mesh is built. In large models this specified e-book support may be difficult and makes space in modeling errors. Solid modeling is often more effective and scalable than direct technology and a model generation technique is usually required.

➤ **Mesh generation:**

As part of the assessment of finite data, the most important notion is to look at how discrete, so-called factors (also known as nodes) are structured. In this context, these variables and nodes are referred to as loading boundaries. Mesh refers to a collection of several variables.

➤ **Finite element generation:**

FEM analysis requires a large amount of time spent creating elements and nodal data. The preprocessor allows a user to concurrently create nodes and elements in order to alter the length and range of the elements. It is possible to map or produce a wide variety of items in various geometrical bodies.

The preprocessor's numerous automated element technical skills may be used to check for components that can be proven prior to the finite element analysis of connection, distortion

index, etc. Instead of specifying my part's nodes, mesh capabilities for preprocessor creation are employed. Defining allocations or translating existing nodes is all that is required to define a node. Nodes may be plotted, erased, or scanned.

➤ **Conditions and loads at the boundary:**

The findings of the finite element analysis must be limited and loaded when they have been finished. Hundreds of constraints may be described in a variety of ways by the user. All limitations and eras are included in Set 1D. In this way, a person can handle a wide range of load conditions.

➤ **Model display:**

During the model's creation and verification, it may be necessary to examine it from several perspectives. It's a good idea to flip the model over and examine the global device from several perspectives. The preprocessor has this functionality. The window feature can be used to improve the readability and detail of an area of the version. The preprocessor also provides smoothness, scaling, fields, active collection, and other features.

➤ **Material definitions:**

The easiest approach to explain all components is to use nodes that represent their immediate surroundings. Plate and shell factor thickness is not specified. An exact measurement of this thickness may be provided. Tables must be entered for a particular set of 1-D characteristics. For example, different components have their own houses. Spiral and inertial beams are examples of sectional beams. Shells: Springs of thickness: Solids of thickness: None

In addition, the customer wants to be able to specify the criteria for textile homes. Linear static analysis requires elasticity modules and the Poisson ratio. The heat transmission depends on the thermal growth, density, and other factors. The elements may be given fabric characteristics set to 1-D.

➤ **Solution:**

According to the issue definitions, the answer section provides a solution. In order to develop and build the matrices and finally the output of displacement and stress levels, the

computer does the tiresome job. Linear static analysis, nonlinear static assessment and quick dynamic assessment are only a few of the ANSYS' numerous capabilities.

➤ **Post – Processor:**

Upgrading in a user-friendly manner is made possible with the usage of interactive shade graphics. To show the results of the finite element analysis, it provides a wide range of charting capabilities. A table of results, for example, may frequently be shown in seconds, showing the engineer's time from a numerical production in an image (i.e. outcomes are apparent in some manner). In addition, the engineer can point out the most important aspects of the findings, which a list of numerical data would miss. In order to provide the user with the most freedom and convenience, command/menu mode of different kinds of analyses provides access to all processing choices.

CHAPTER 4
DESIGN AND ANALYSIS OF FINS MODEL

CHAPTER 4

DESIGN AND ANALYSIS OF FINS MODEL

4.1. General

A fin refers to the protruding part of a fish's body that extends from the bottom. In order to enhance the rate at which heat is dissipated from or to the environment, fins are utilised to increase convection rates. An object's entire convection, conduction, or radiation selects the heat rate it assigned. Temperature variations between the object and its surroundings increase the convection coefficient or surface area, which leads to more heat exchange. However, as the surface area increases, so does the resistance to heat movement. As a result, the coefficient of heat transfer of a base is determined by its total area, which is less than the base's. Experiments to discover changes in temperature inside fins in three types of geometrics were performed (plating fins, perforation of circulation and rectangular perforation) with Checking and approving findings using ANSYS finite-element software FEM is used to analyses temperature fluctuations in different plate fin regions and the results of plate fins in experimental Ansys are compared with. The principle used in this project is to expand the rate of heat discharge through the use of wind flow. The principal objective of the thesis is to boost thermal properties by mixing geometry, material and fine design.

4.2. Thermal Analysis of Fins Model in Ansys

Plate Fins, circular perforation, pin fins with circular form, and draught pin fins are three Fins types made here utilizing aluminum alloy 1060. Fins with plate fins and circular perforations, as well as draft pin fins and circular perforation pin fins, are used to flow air through fins for optimal heat transfer. The FEM study was carried out using Ansys. The shorthand for the actual application of finite element modeling is FEA, or finite element analysis. FEA is widely used in the automotive sector. It is a widely used tool in the product development process for creating configurations. To make FEA a useful design tool, one must understand the fundamentals of the FEA design process, exhibiting systems, the inherent faults, and their influence on the nature of the results. Additionally, FEA may be utilized as a computational tool to solve engineering problems.

Experimental fins models are examined using ANSYS, a commercially available partner simulation software package that provides a comprehensive organization that extends across all types of physics and is suitable for use in a wide range of thermal engineering design applications. In order to test a digital product before it becomes a widespread feature, the software package makes use of its equipment, such as Fins models, under a variety of loading scenarios.

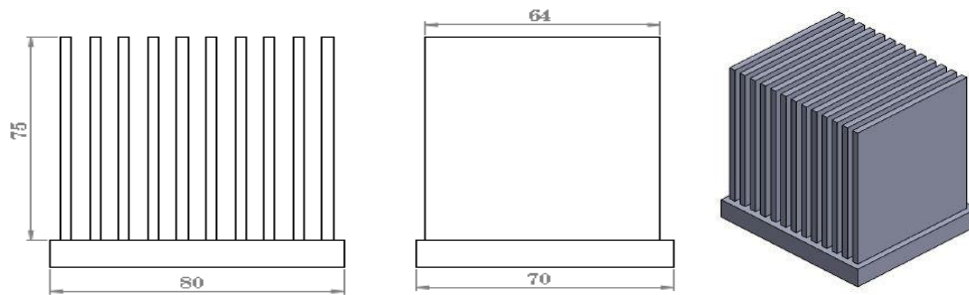

Figure 4.1: Plate Fins Designed Model in Ansys

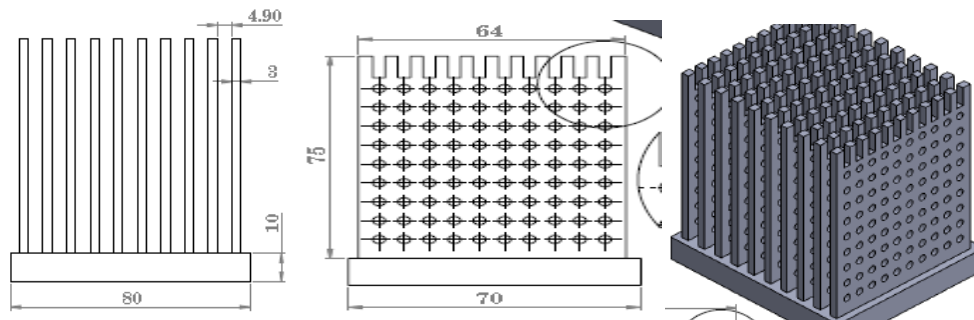

Figure 4.2: Circular Perforation in plate fins designed Model in Ansys

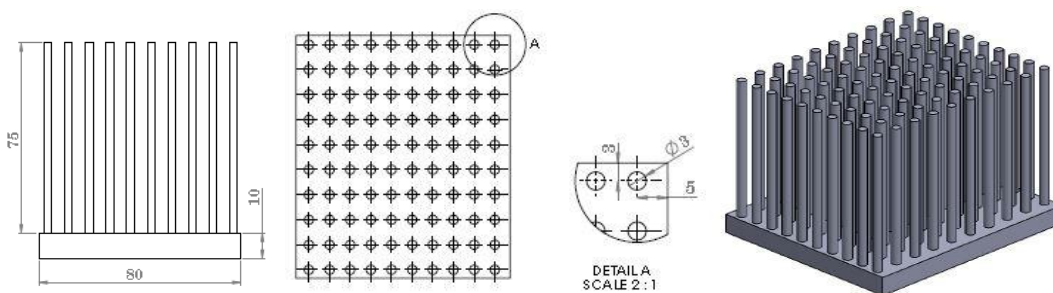

Figure 4.3: Ansys model of a circular pin fin

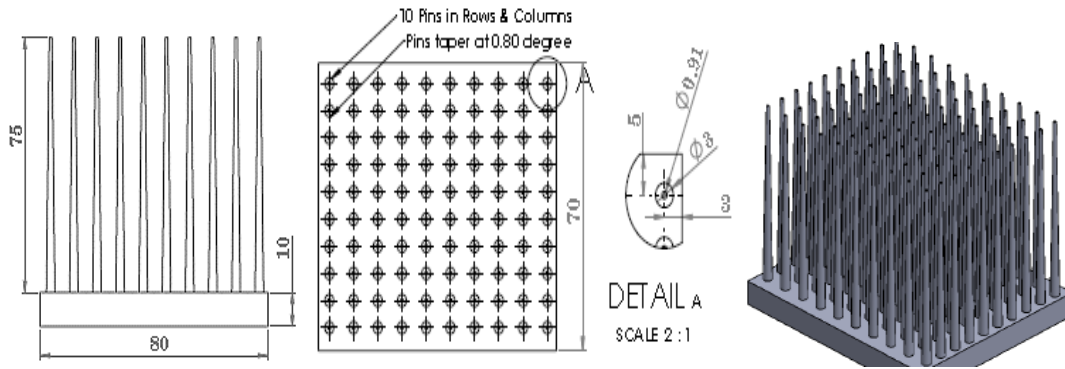

Figure 4.4: Conical Draft pin fins designed Model in Ansys

Table 4.1: Dimensions of Fins Model

Sr. No.	Fins Model Dimensions	Values (mm)
1.	Cross Section area of Plate Fins base	80 x 70
2.	Rectangular hole	3 x 2
3.	Diameter of circular hole	3

4.3. Modeling of Fins

Modeling of the Fins done using Solid work has been explained in detail. Research into finite elements is aimed at re-creating the mathematical properties. The model incorporates all nodes, components, material qualities, particular constants, limitations and other features required to define the physical system. After the models have been created, the specified nodes will be subjected to boundary conditions, and finally, the final analysis will be carried out.

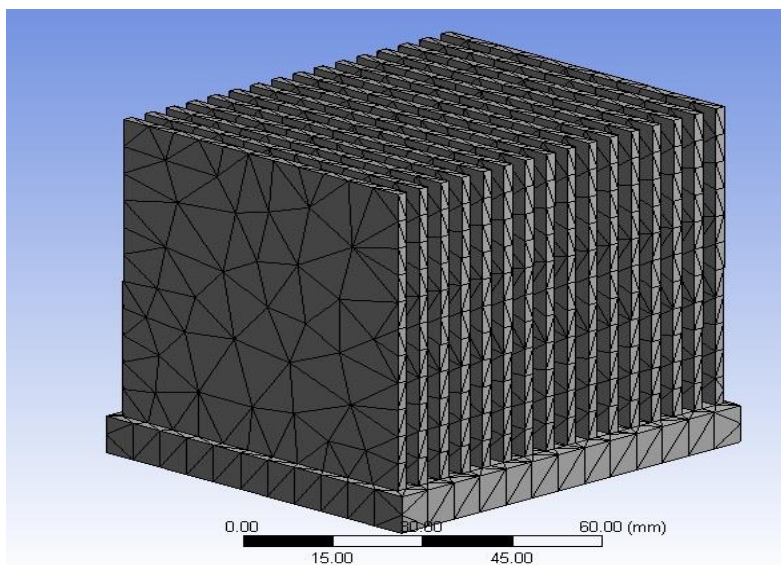

Figure 4.5: Meshed Model of Fins without holes

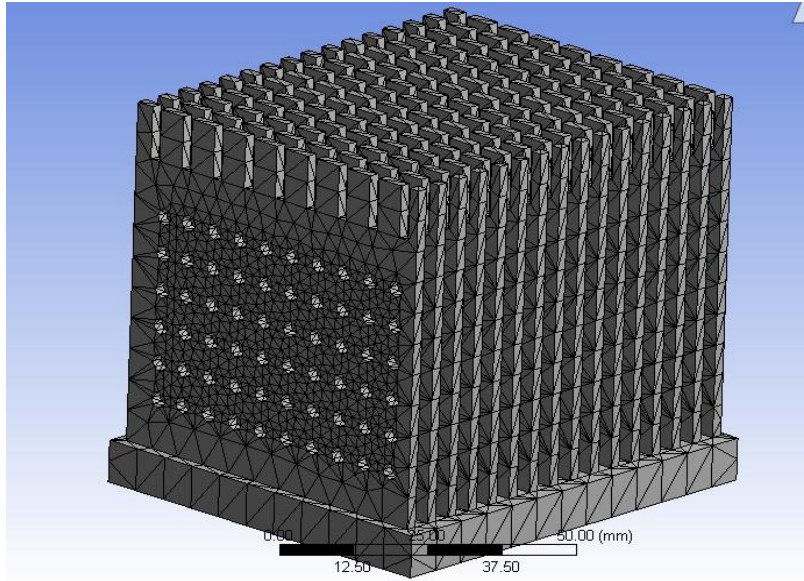

Figure 4.6: Meshed Model of Fins with Circular holes

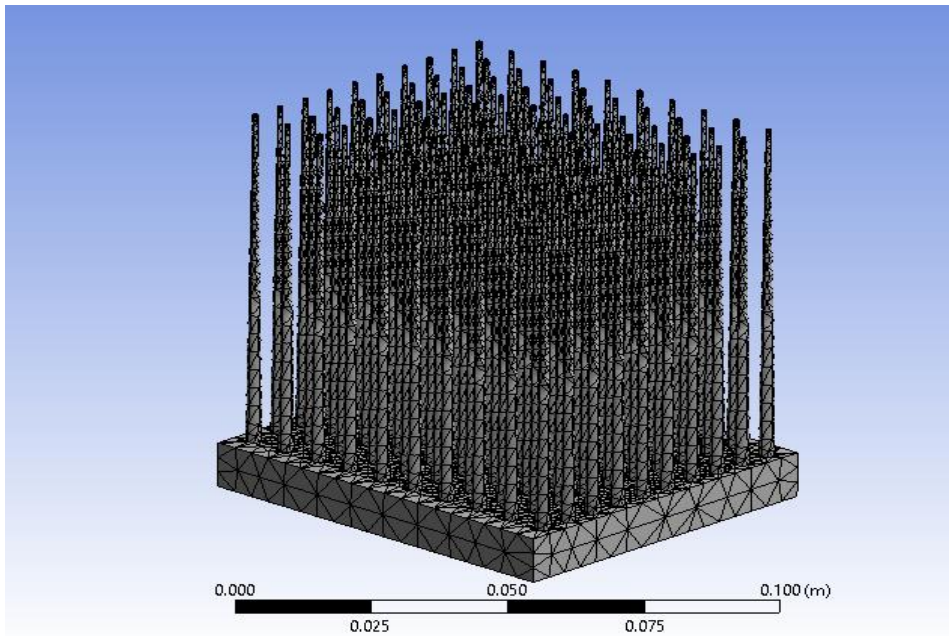

Figure 4.7: Meshed Model of Draft Pin Fins

4.4. Material Properties

Table 4.2 shows the composition of the Aluminum alloy used in the Fins material for thermal investigation.

Table 4.2: Material properties of Fins Model

Parameters	Units	Aluminum alloy (1060)
Density	(Kg/m ³)	2700
Young's Modulus	(MPa)	69000
Coefficient of thermal expansion	(1/K)	2.3×10^{-5}
Poisson's Ratio	-	0.33
Elastic modulus	(GPa)	70
Ultimate Tensile Strength	(MPa)	310
Thermal conductivity	(W/m ⁰ C)	200

4.5. Applying boundary conditions

In order to maximise performance, the boundary conditions shown in Figures 4.7, 4.8, and 4.9 have been applied to the Fins Model with a heat flow of 20 W and convection conditions of 22 0c. In order to achieve a high heat transfer rate, the maximum and lowest temperatures are also optimised. Figure depicts the Fins Model's applied boundary conditions.

Table 4.3: Boundary conditions of Fin model

Fin models	Heat supply added to the base	Heat rejected to the air at convection temperature
Fins without holes	20 Watt	22 ⁰ C
Fins with Circular holes	20 Watt	22 ⁰ C
Fins with Rectangular holes	20 Watt	22 ⁰ C

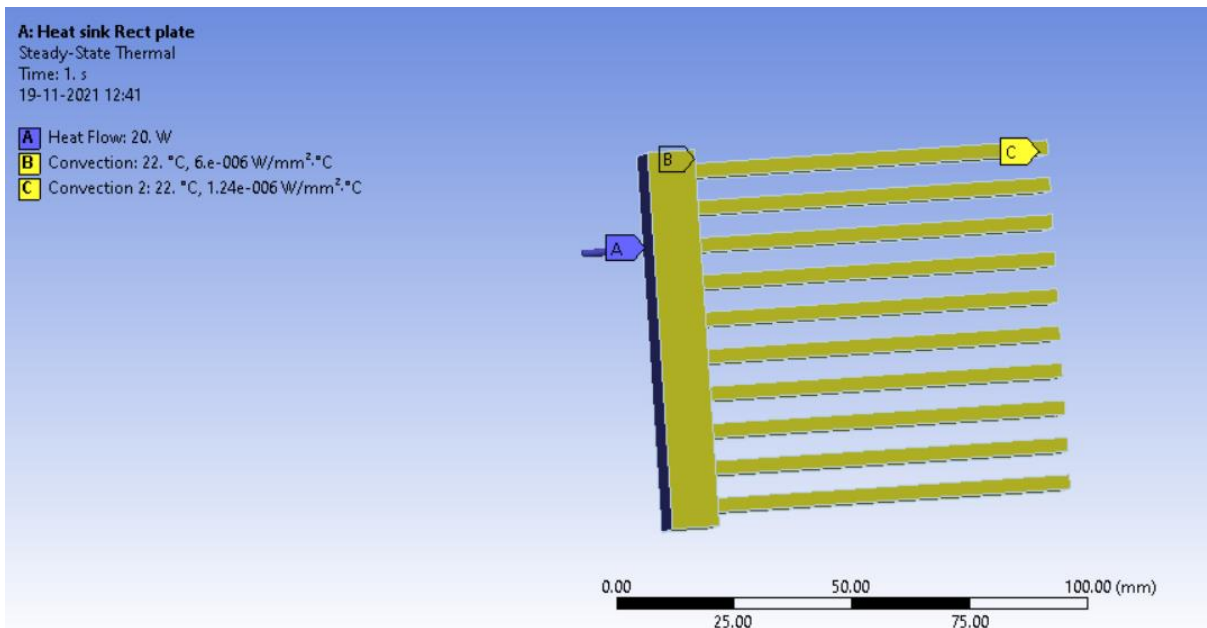

Figure 4.8: Plate Fins with Applied Boundary Condition

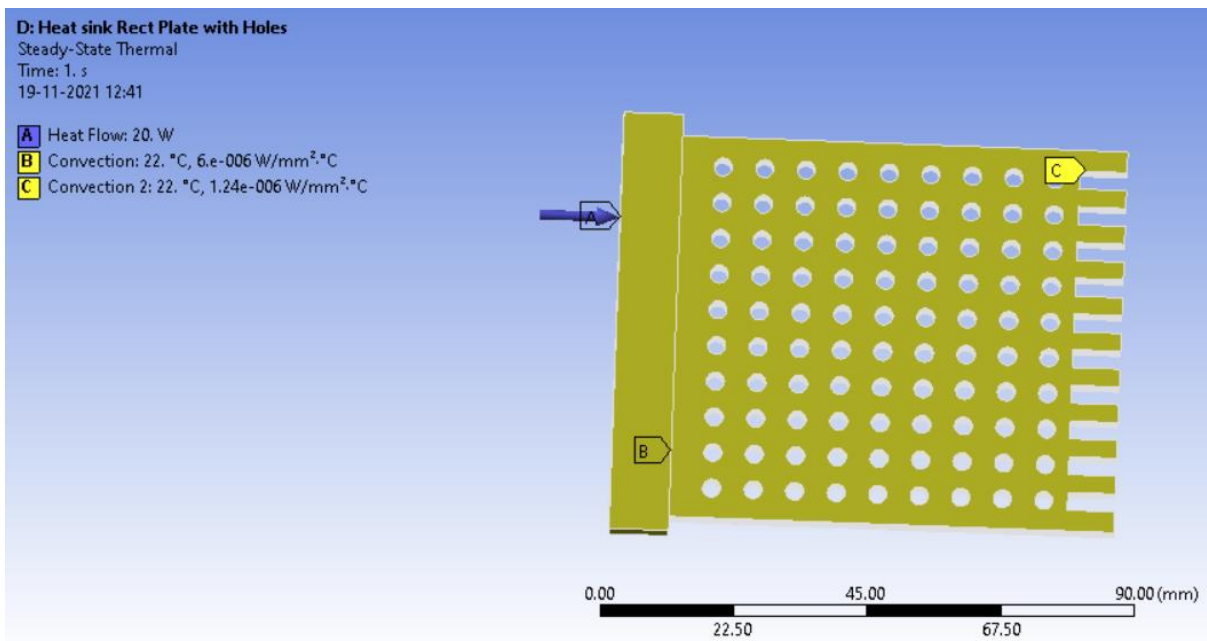

Figure 4.9: Boundary constraints applied to plate fins with circular holes

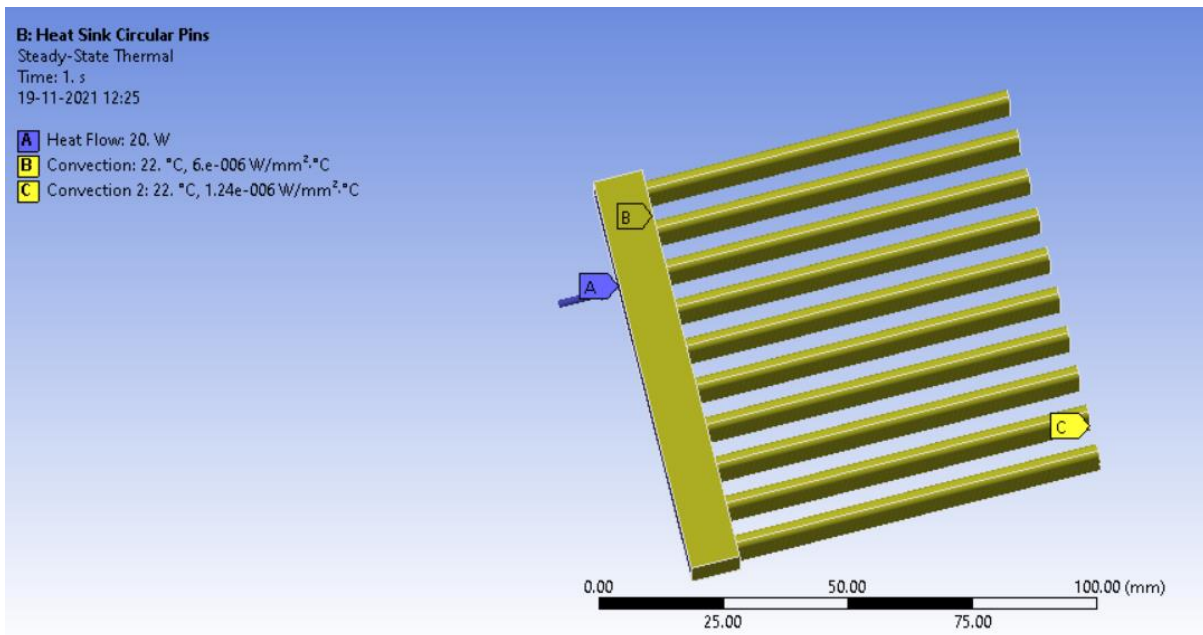

Figure 4.10: Circular Pin Fins with Boundary constraints applied

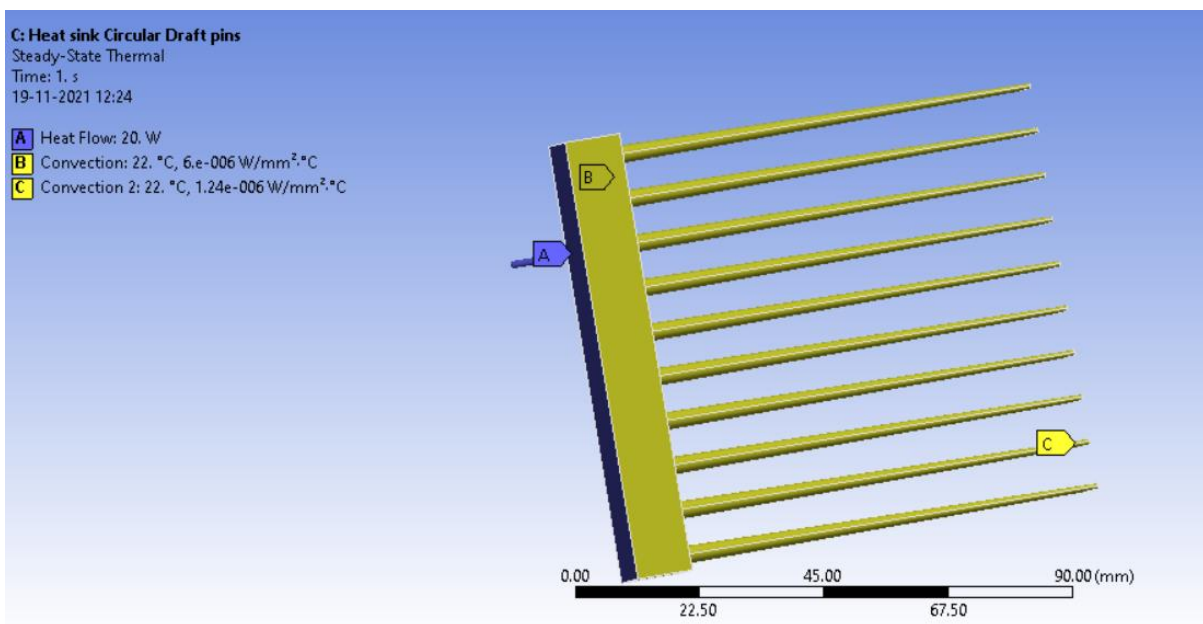

Figure 4.11: Applied Boundary conditions on Draft Pin Fins

The thermal analysis of Fins models is performed in Ansys and Compared the Plate Fins performance with the perforation's fins. The present examination gives the heat exchange investigation between plate fins and perforated fins. Perforated fins composed in two shapes (circular perforation and rectangular perforation) fitted with tube-shaped cross-sectional so as to decide better improvement in the heat exchange rate. we have optimized Heat exchange rate and optimized with all perspectives to get higher Heat exchange rate.

CHAPTER 5
RESULTS AND DISCUSSION

CHAPTER 5

RESULTS AND DISCUSSION

5.1 Introduction

Static thermal analysis performed to find out best design of Fins for maximum heat transfer rate in Fins. There are three different design fins model designed and analyzed in ANSYS by assigning the Material properties of fins models. The temperature-dependent variation of a material's physical property is determined using a variety of thermal analysis techniques. Calculating changes in mass or energy of a material model is by far the most common approach. It is possible to see the temperature fluctuation across different piston heights in a steady-state scenario by using fins models with boundary conditions. The temperature variations in plate fins and perforated fins models were examined and graphed for comparison following the processing solution.

5.2. Results and Discussion

The fundamental frame is broken down into a mesh with only a few measurable components to study the Fins model. To calculate displacement throughout each segment, a basic polynomial profile capacity and nodal temperature are assumed. Conditions are being created to elicit strains and stresses in relation to the unexplained nodal temperature. The criteria of balance are summarized in a grid structure that may be readily rearranged and reordered. Figures depict the steady-state temperature fluctuation over different Fins heights and the boundary conditions imposed. The temperature reaches its highest point at the summit. A thermal examination of temperature and total heat flux compared the plate fins and perforated-fins models after processing. All three situations, i.e. Plate fins, Fins with circular perforation, and Fins with conical draught type pin, provide the same structural and thermal analysis findings. Ansys simulations of Fins models are shown in the figures 5.1-5.8.

After designing the Fins model in Solid Work, the IGS FILE was converted to IGES format. This configuration is compatible with the ANSYS software. When the design was loaded into ANSYS, the analysis began. The Fins model under consideration has been deconstructed into a mesh of small-scale pieces. The steady state condition has been examined, and the appropriate boundary conditions are shown in the figures. Following the solver run, a temperature and total heat flow were found. To achieve these outcomes, geometric variations of rectangular plate

fins with and without perforations, circular fins with holes in the center, conical fins, and circles fins shape were all designed.

➤ **Temperature distribution analysis of Fins Models**

Thermal research of fins has shown a maximum temperature of 59.64 oC for fins without holes on rectangular plates and a minimum temperature of 56.75 oC for fins with holes on rectangular plates. Maximum Temperature drop is found in Conical draft pin fins.

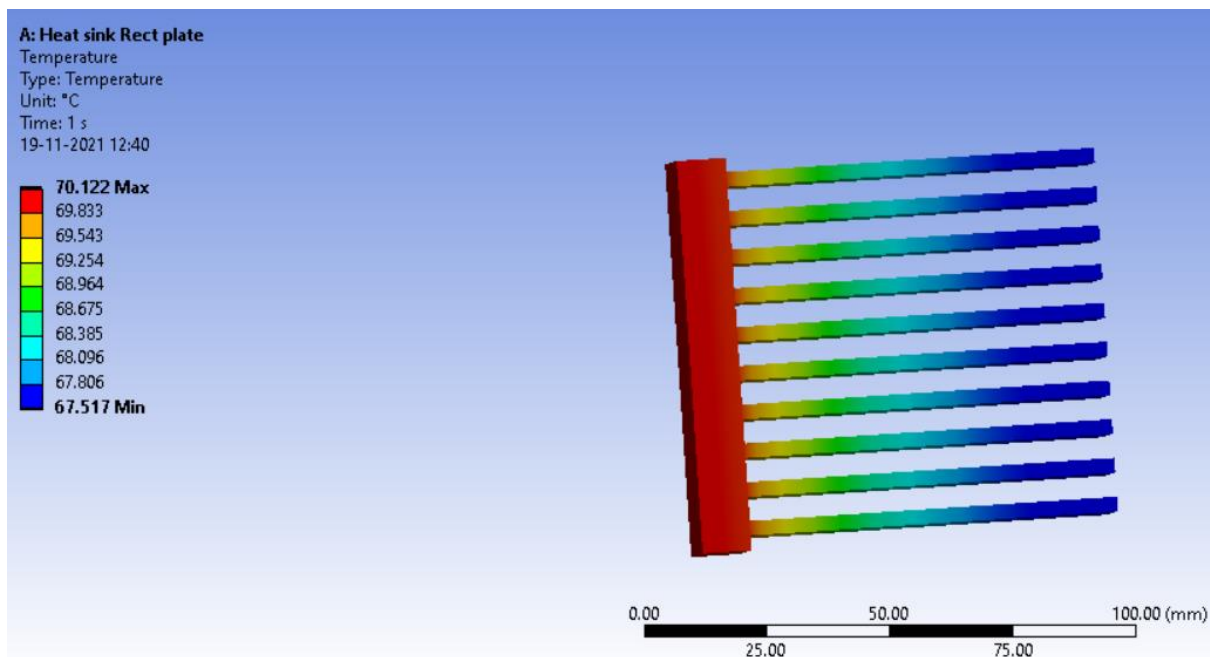

Figure 5.1: Plate Fins' Temperature Dispersion.

Figure 5.1 shows the temperature variations in fins during heating and heat rejection due to convection , maximum temperature found 70.122 °C and minimum temperature found 67.517°C.

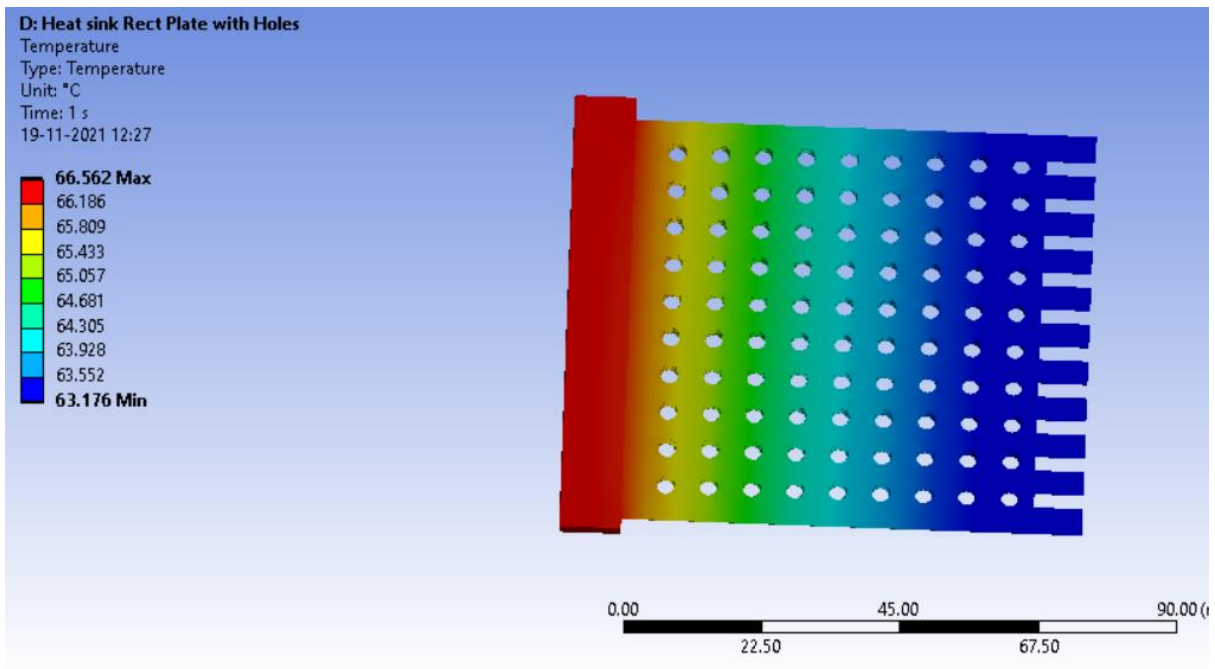

Figure 5.2: Temperature Distribution of Rectangular plate Fins with holes

Figure 5.2 shows the temperature variations in fins during heating and heat rejection due to convection, maximum temperature found 66.56°C and minimum temperature found 63.176°C .

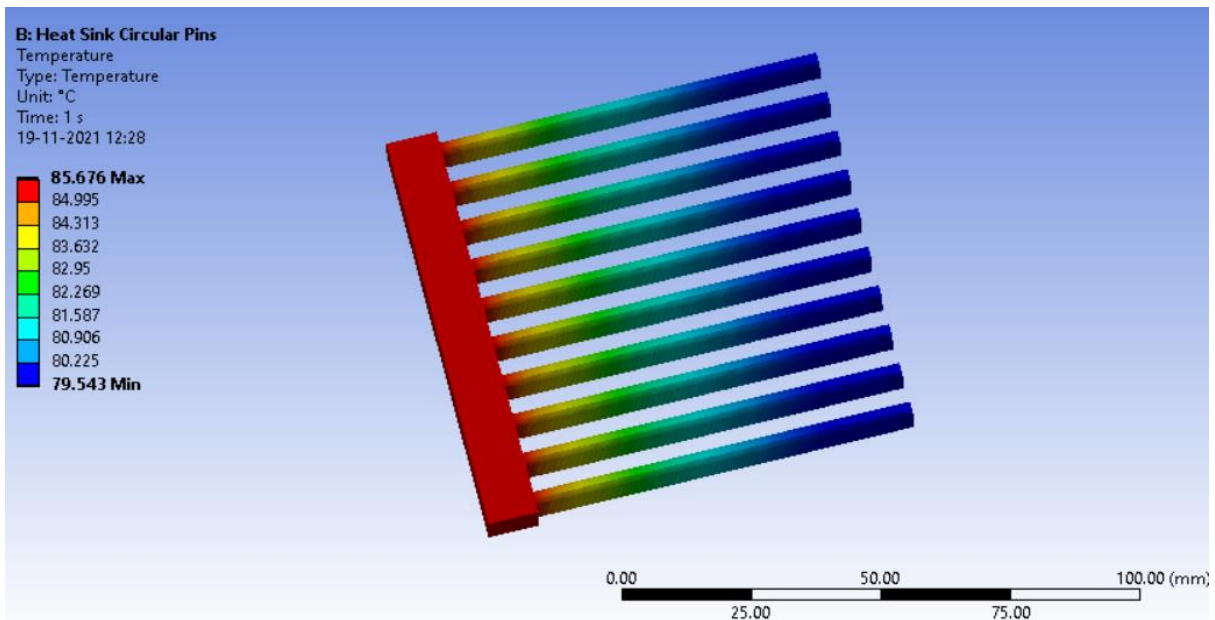

Figure 5.3: Temperature Distribution of Circular Pin Fins

Figure 5.3 shows the temperature variations in fins during heating and heat rejection due to convection, maximum temperature found 85.67°C and minimum temperature found 79.54°C .

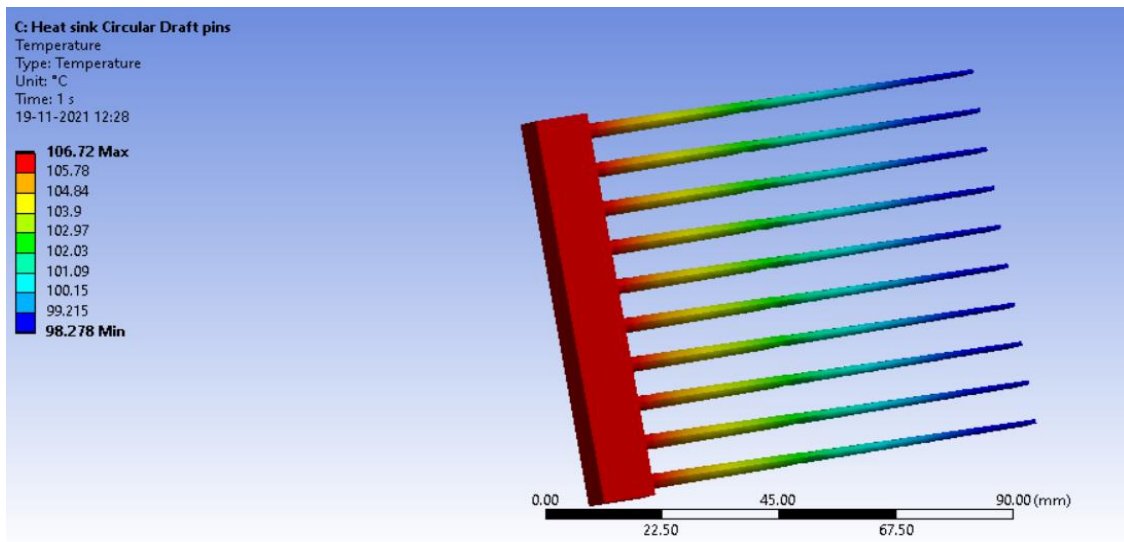

Figure 5.4: Temperature Distribution of draft conical Pin Fins

Figure 5.4 shows the temperature variations in fins during heating and heat rejection due to convection, maximum temperature found $106.72\text{ }^{\circ}\text{C}$ and minimum temperature found $98.27\text{ }^{\circ}\text{C}$.

➤ **Heat Flux and thermal stress analysis of Fins Models**

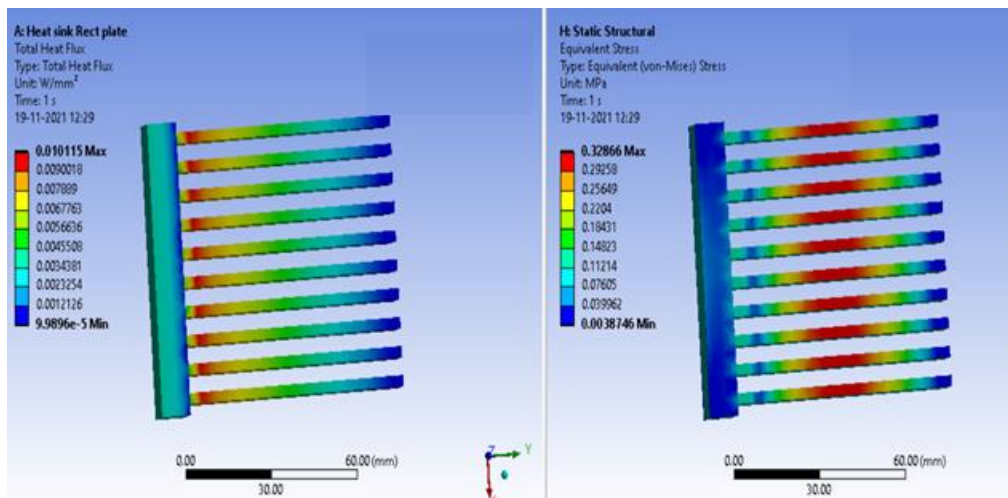

Figure 5.5: Heat Flux and Stress of Plate Fins

Figure 5.5 shows the Heat flux variations in fins during heating and heat rejection due to convection, maximum Heat flux found 0.0101 w/mm^2 .

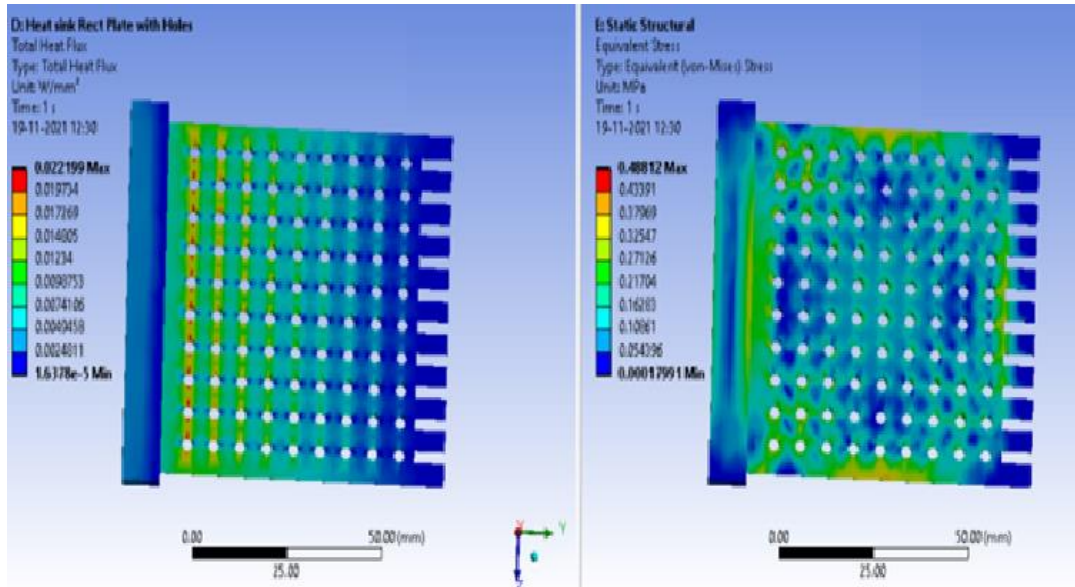

Figure 5.6: Heat flux of Rectangular plate Fins with holes

Figure 5.6 shows the Heat flux variations in fins during heating and heat rejection due to convection, maximum Heat flux found 0.0221 w/mm^2 .

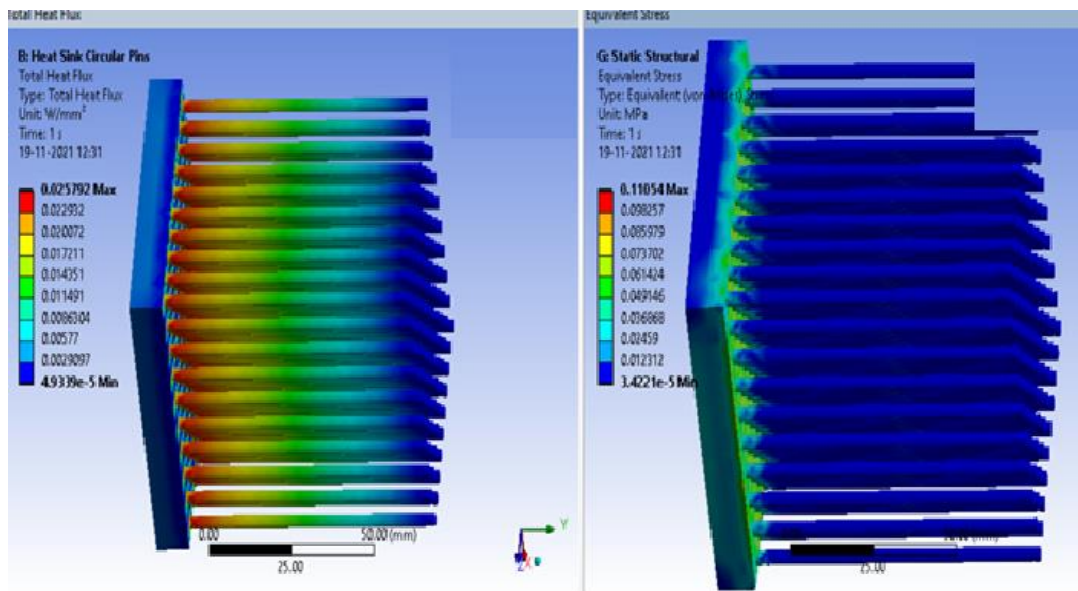

Figure 5.7: Heat flux and Stress of Circular Pin Fins

Figure 5.7 shows the Heat flux variations in fins during heating and heat rejection due to convection, maximum Heat flux found 0.0257 w/mm^2 .

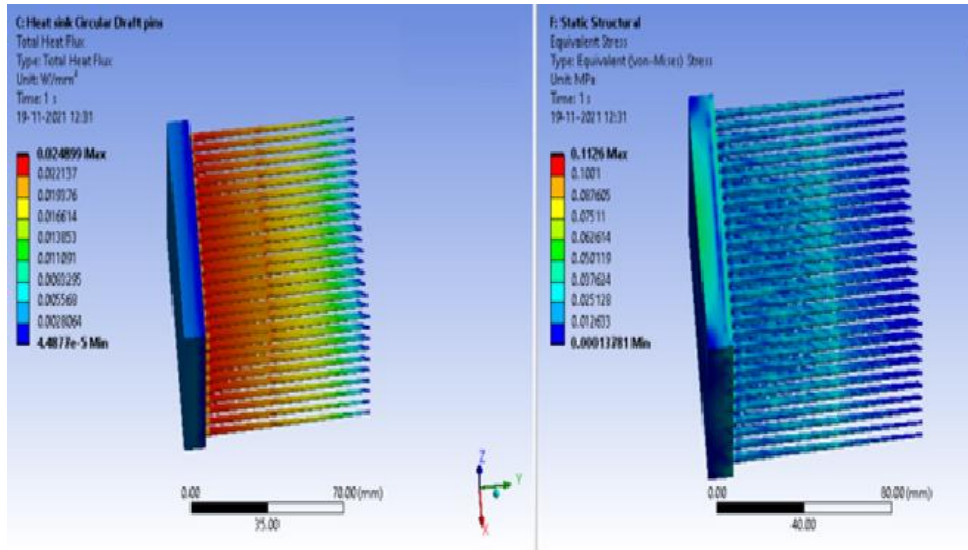

Figure 5.8: Heat flux and Stress of Circular Pin Fins

Figure 5.8 shows the Heat flux variations in fins during heating and heat rejection due to convection , maximum Heat flux found 0.0248 w/mm^2 .

Table 5.1: Shows the Maximum and Minimum temperature variations

Geometry Condition	Heat Flow (watt)	Max Temperature (°C)	Min Temperature (°C)	Temperature drop(°C)
fins with rectangular plate	20	70.12	67.51	2.61
Circular pin fins	20	85.67	79.54	6.13
Conical draft pin fins	20	106.72	98.27	8.45
Rectangular plate fins with holes	20	66.56	63.17	3.39

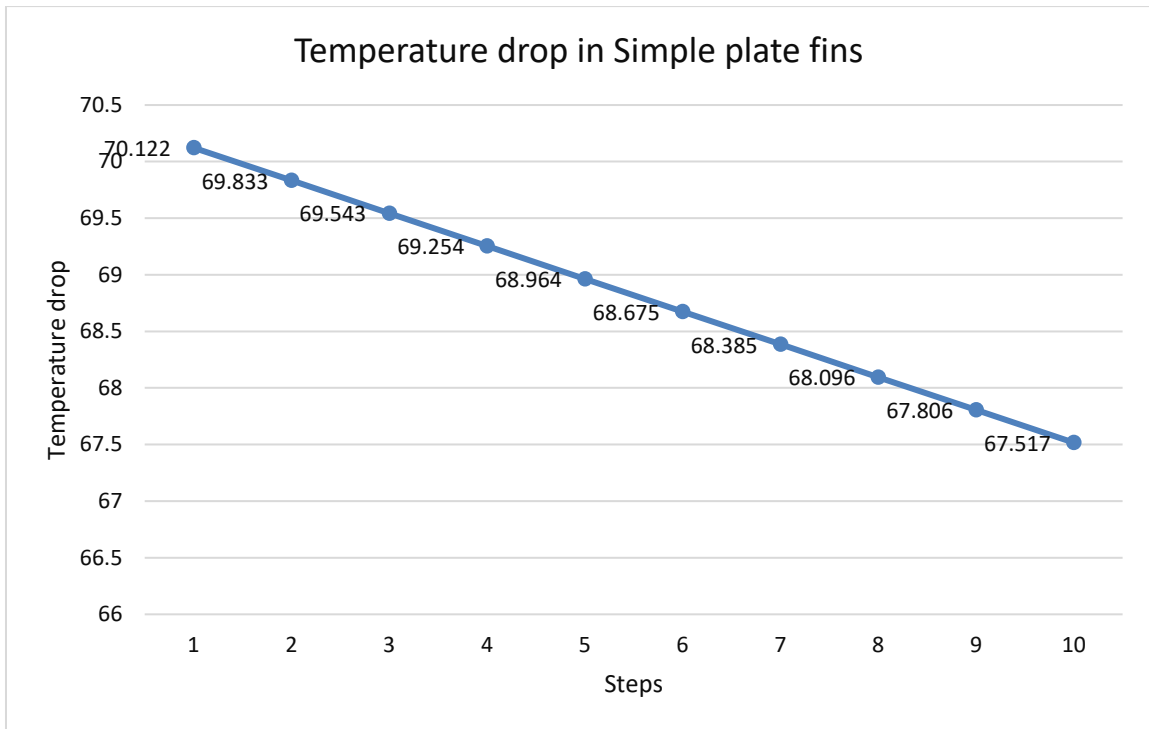

Figure 5.9: Temperature drop in simple plate fins model

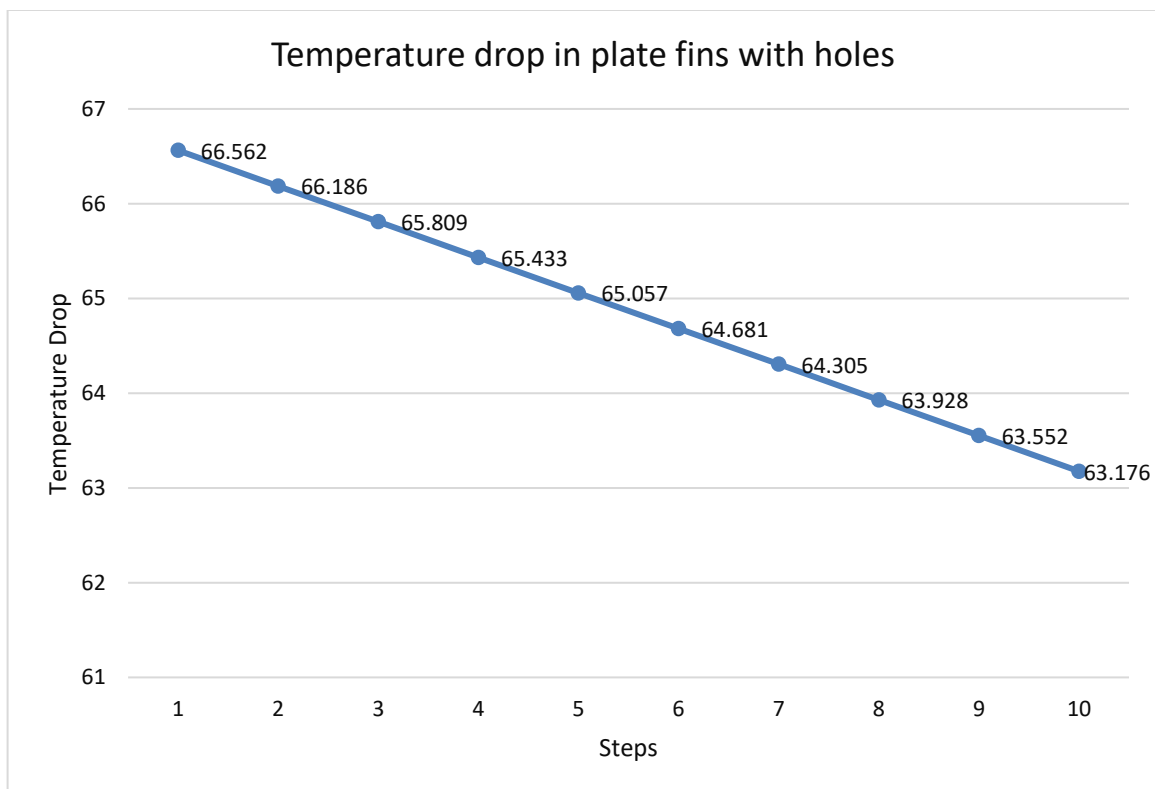

Figure 5.10: Temperature drop in plate fins with holes model

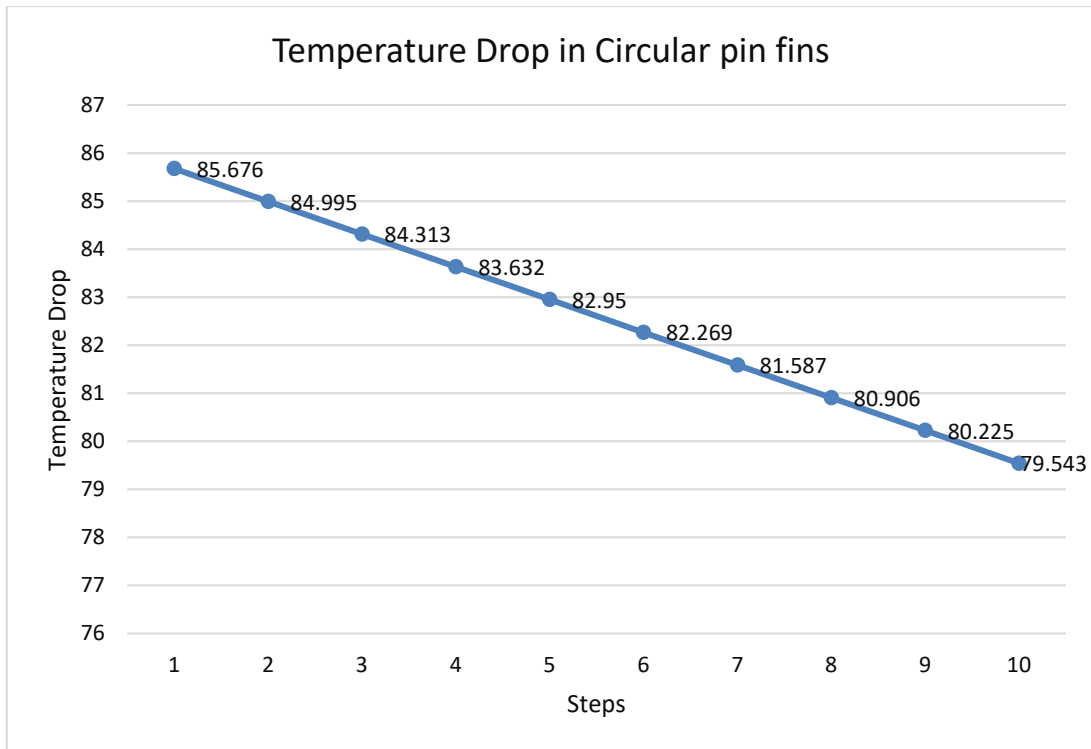

Figure 5.11: Temperature drop in circular pin fins model

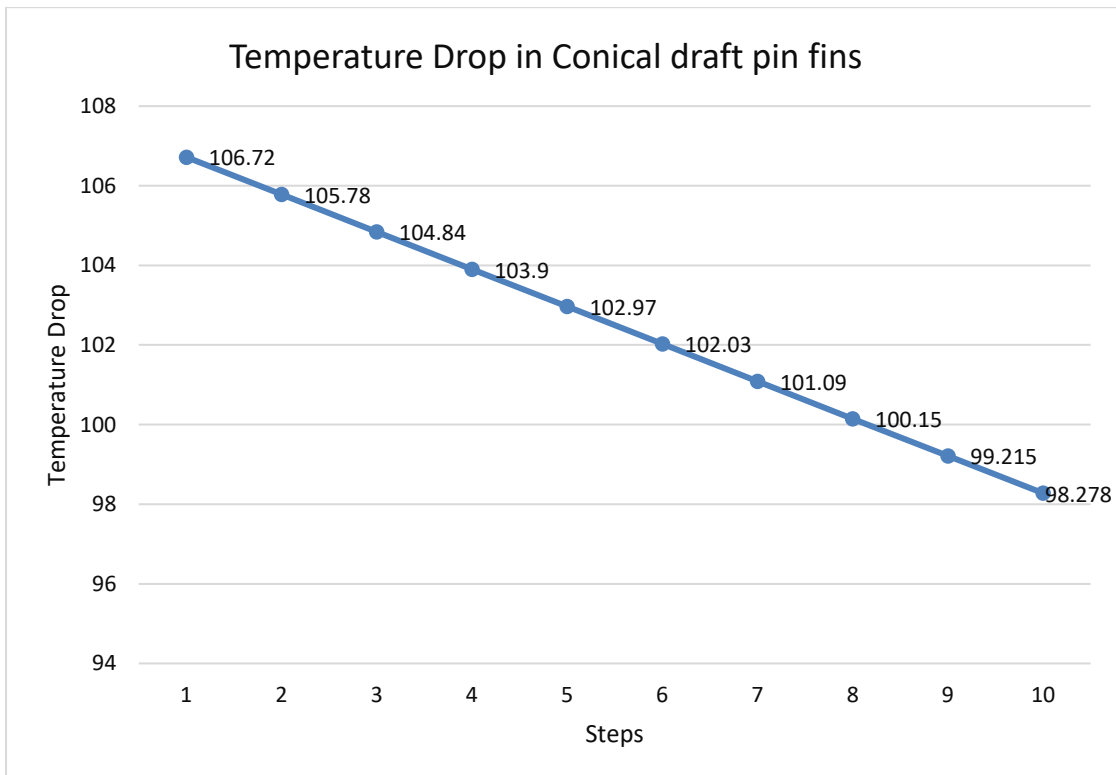

Figure 5.12: Temperature drop in conical draft pin fins model

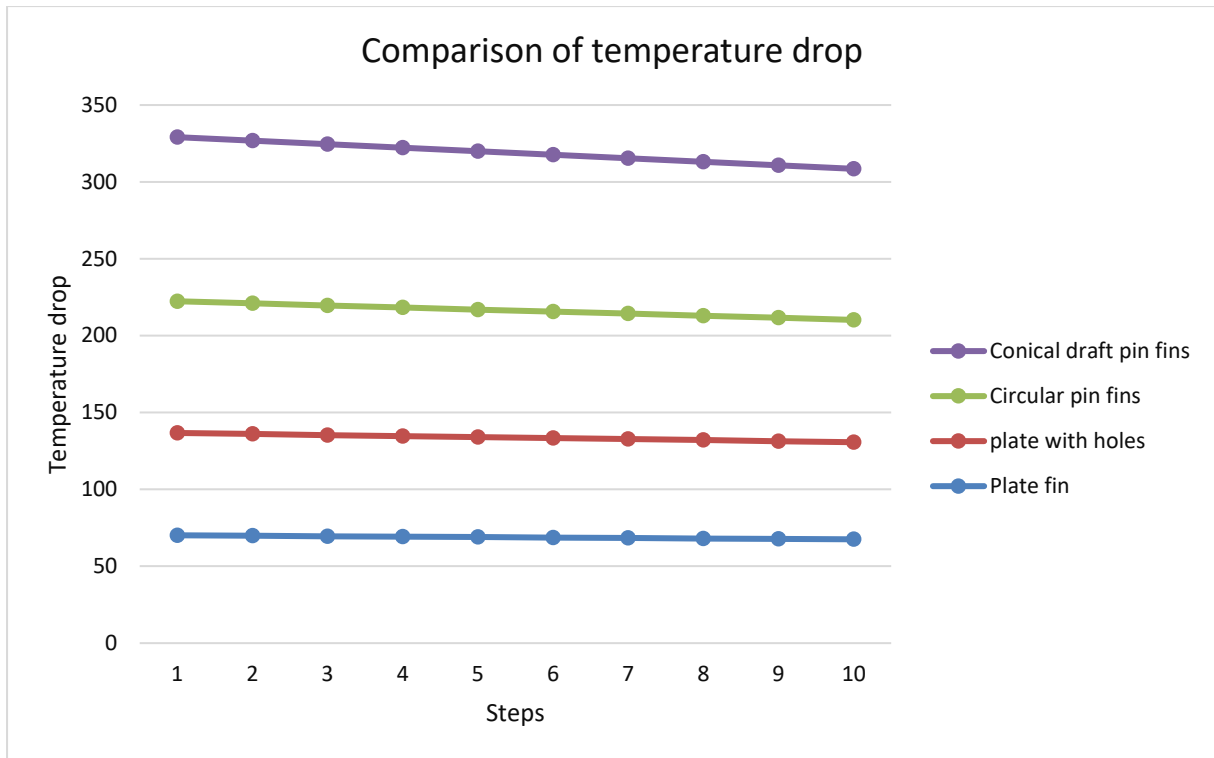

Figure 5.13: Comparison of Temperature drop in all fins model

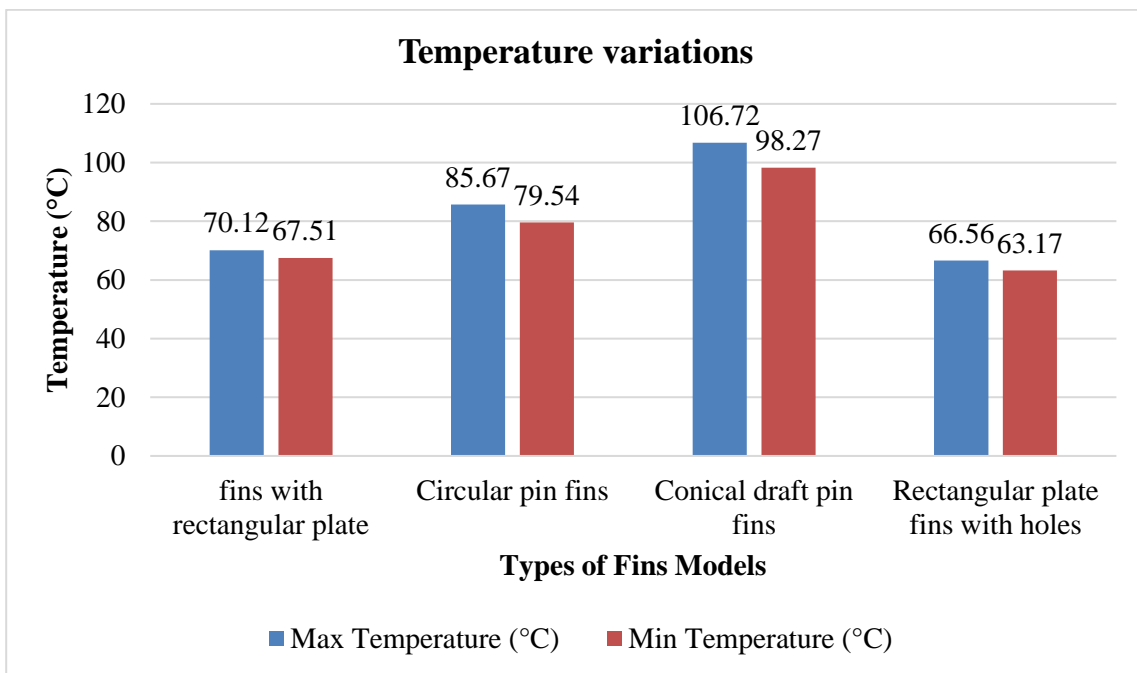

Figure 5.14: Maximum and Minimum Temperature found on Fin Models

Figure 5.14 shows the maximum and minimum temperature variations in design fins model during simulation analysis. Maximum temperature found on conical draft fin is 106.72 °C.

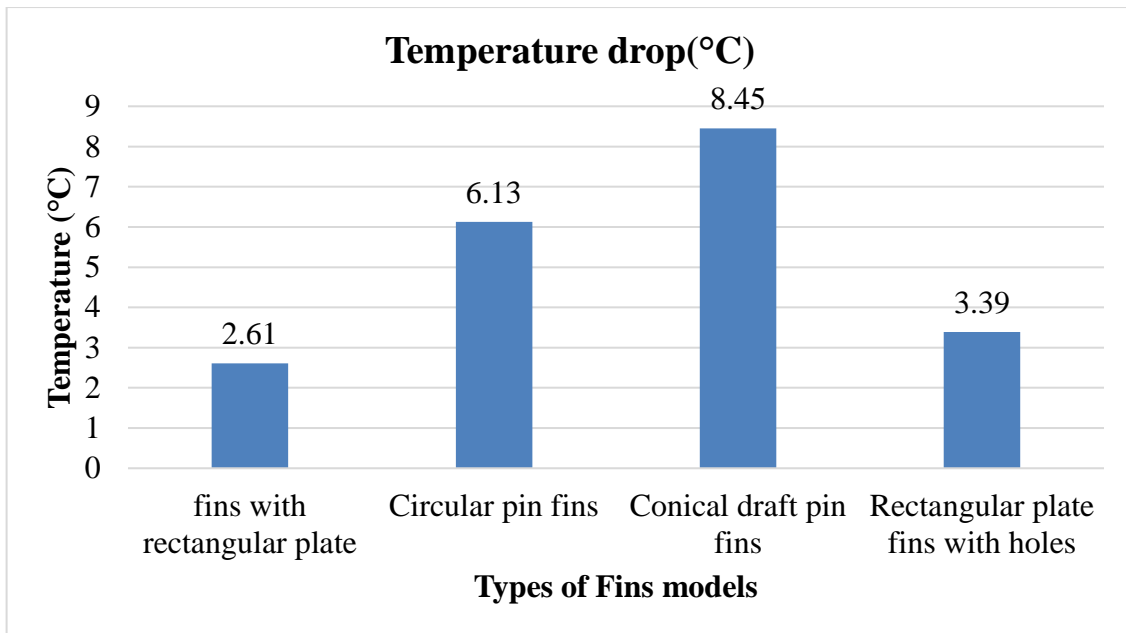

Figure 5.15: Total Temperature drop variations in Fin Models

Figure 5.15 shows the temperature drop on designed fins models during simulation analysis. The conical draught pin fin form has the highest temperature decrease, whereas the plain rectangular variant has the lowest temperature drop. So, it shows the changes in fins shape causes increment in heat transfer rate.

Table 5.2: Heat Flux Found on All conditions of Fin Models

Geometry Condition	Heat Flux (W/mm ²)	Thermal Stress (MPa)	Weight(kg)
fins with rectangular plate	0.0101	0.32	0.554
Circular pin fins	0.0257	0.11	0.301
Conical draft pin fins	0.015	0.074	0.223
Rectangular plate fins with holes	0.014	0.322	0.48

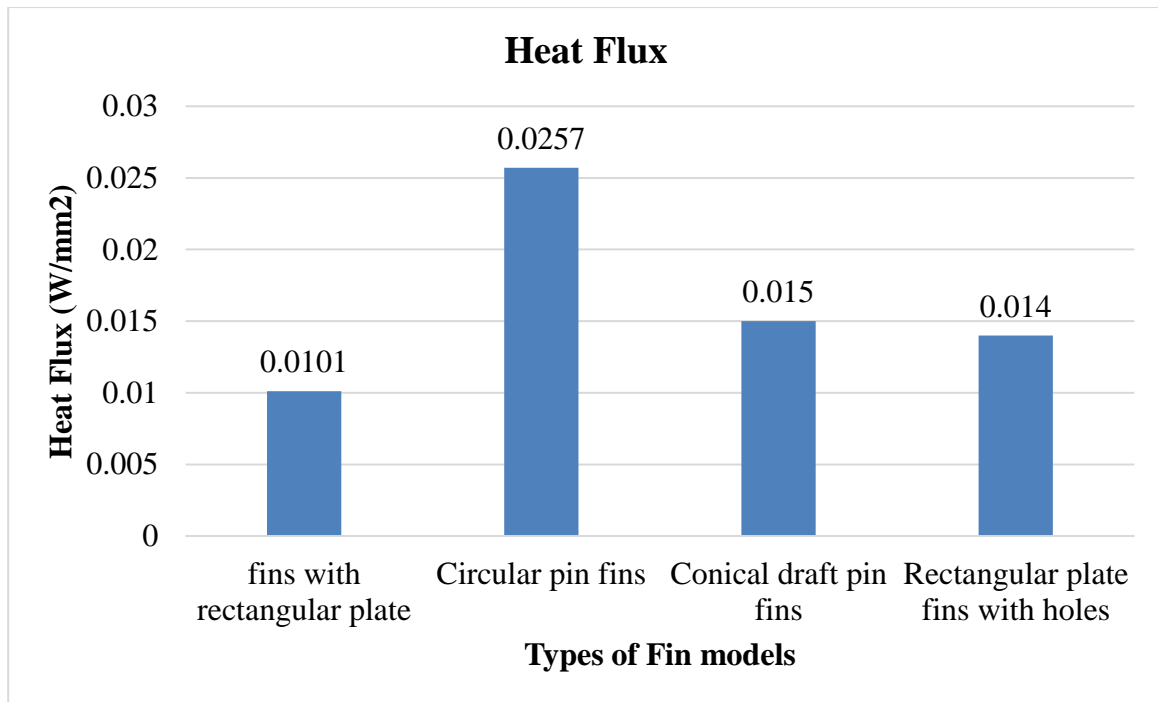

Figure 5.16: Comparison of Heat flux of Fin Models

Figure 5.16 shows the maximum heat flux on circular pin fins and minimum found on fins with rectangular shape.

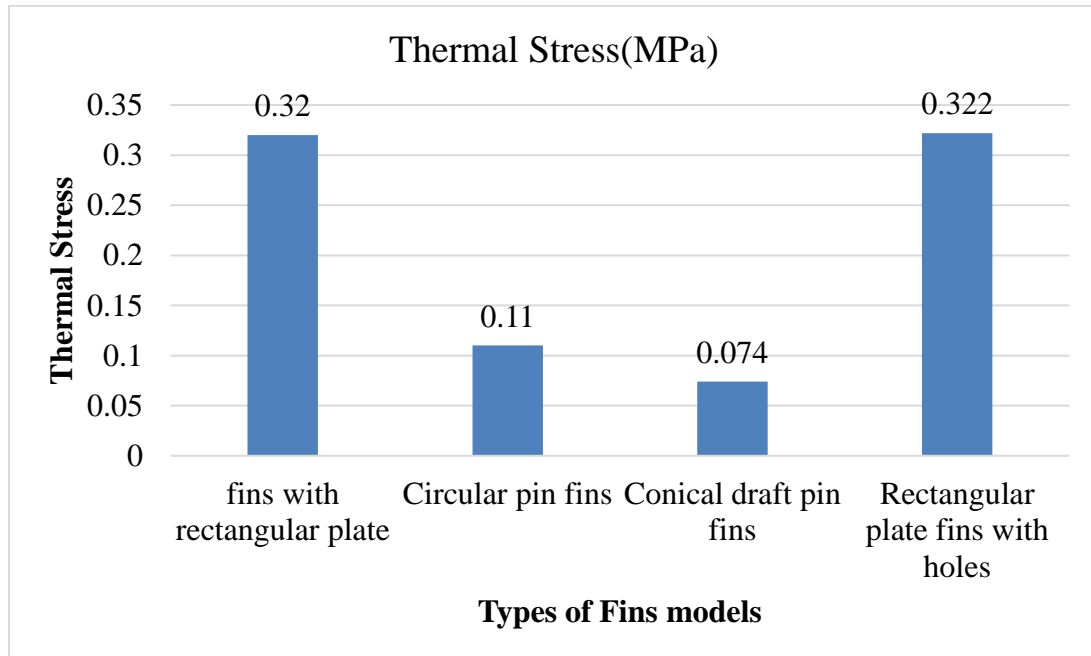

Figure 5.17: Comparison of Thermal Stresses of Fin Models

Figure 5.17 shows the thermal stresses comparison of heat fins maximum thermal stresses found on rectangular fins and minimum thermal stresses found on conical draft pin fins.

CHAPTER 6
CONCLUSIONS

CHAPTER 6

CONCLUSION

6.1. Conclusion

After comparing Circular Pin fins, plate Fins, plate Fins with holes, and draught Pin fins, researchers concluded that Circular Pin fins had the highest total heat flux of 0.0257 W/mm². Conical draught Pin Fins have a maximum temperature of 106.72⁰C and a minimum temperature of 63.17⁰C.

As per our study if we find out the difference between heating and cooling after convection then we have calculate difference between maximum temperature to minimum temperature.

a maximum temperature drop of 8.45⁰C was recorded on the conical draught pin fin, while a lowest temperature drop of 2.61⁰C was registered on the plate fin.

Since Pin Fins with a conical draught demonstrate higher heat transmission capabilities in this study, it may be inferred. Conical draught Pin Fins, on the other hand, have a superior heat transfer rate than plate Fins, as shown by a test. Also, we can compare the design between plate fin and pin fin so, we find out maximum heat transfer output on pin fins then plate fins. ANSYS FEM analysis Tool is used to do the majority of the work. Further study may be carried out using advanced materials and other design, analytic methods. The following findings may be drawn from the research described above:

- Thermal analysis for fins has been completed by adjusting other parameters, including geometry, plat fins, circular perforation in plate fins and pin fins.

- While looking at the results of the experiment, Conical Pin Fins, as opposed to Plate Pins, have a lower temperature drop and a higher heat transfer rate, making their usage with aluminium alloy considerably simpler.

6.2. Future Scope

- This Research work can be extended by using various types of Perforations on Fins surface and comparing the output.
- Analysis of Fins Model with Various alloy materials.

REFERENCES

REFERENCES

1. Dhamyaa S. Khudhur, Reyadh ChAl-Zuhairy, Muna S. Kassim, "Thermal analysis of heat transfer with different fin geometry through straight plate-fin heat sinks", *International Journal of Thermal Sciences*, Volume 174, April 2022.
2. Abhay Bele, Akash Chaurasia, Aniket Gavas, "Thermal Analysis of IC Engine Bore Fins", *International Journal of Innovative Research in Science, Engineering and Technology (IJIRSET)*, Volume 11, Issue 4, April 2022.
3. Shankar Durgam, Aniket Kale, Nikhil Kene, "Thermal analysis of fin materials for engine cylinder heat transfer enhancement", *IOP Conf. Series: Materials Science and Engineering*, 2021.
4. Charan, Srivastav, Bharadwaj, "Thermal Analysis on Rectangular Plate Fin with Perforations Using Ansys", *International Journal of Creative Research Thoughts*, 2018.
5. Sangaj, Shinde, Shanediwan, Potdar, Suryawanshi, "Thermal and Parametric Analysis of Pin-Fin", *International Research Journal of Engineering and Technology (IRJET)*, Volume 05, Issue 02, Feb-2018.
6. Kiran Beldar, Avinash Patil, "Design and Analysis of cylinder having longitudinal fins with rectangular notches", *International Journal of Scientific Development and Research (IJS DR)*, 2017.
7. Rajesh, Rahamathullah, Malleswara Rao, "design and optimization of engine cylinder fins by varying Geometry and material with thermal analysis", *International Journal of Core Engineering & Management*, 2017.
8. Mayank jain, Mahendra Sankhala, Kanhaiya Patidar, "heat transfer analysis and optimization of fins by Variation in geometry", *International Journal of Mechanical and Production Engineering*, Volume- 5, Issue-7, Jul.-2017.
9. Kummitha, Reddy, "Thermal Analysis of cylinder block with fins for different materials using ANSYS", *ICAAMM, Elsevier*, 2016.

10. S.Ravikumar, Chandra, Harish, "Experimental and Transient Thermal Analysis of Heat Sink Fin for CPU processor for better performance", *Materials Science and Engineering*, 197, 2017.
11. Sandeep Kumar, Nitin Dubey, "Investigation and Thermal Analysis of Heat Dissipation Rate of Single Cylinder SI Engine", *IJEDR*, Volume 5, Issue 2, 2017.
12. Mogaji, Owoseni, "Numerical Analysis of Radiation Effect on Heat Flow through Fin of Rectangular Profile", *American Journal of Engineering Research (AJER)*, Volume-6, Issue-10, pp-36-46, 2017.
13. Arefin, "Thermal Analysis of Modified Pin Fin Heat Sink for Natural Convection", 5th International Conference on Informatics, Electronics and Vision, 2016.
14. Balendra Singh, Satish Singh, "A Research Paper on Heat Transfer in Notch Fin and UN Notch Fin", *International Journal for Research in Applied Science & Engineering Technology (IJRASET)*, Volume 4 Issue IX, September 2016.
15. Kongre, Barde, "A Review Paper on Thermal Analysis and Heat Transfer of Single Cylinder S. I. Engine Fins", *International Journal of Engineering Research & Technology (IJERT)*, Volume 4, Issue 30, 2016.
16. Natrayan, Selvaraj, Alagirisamy, "Thermal Analysis of Engine Fins with Different Geometries", *International Journal of Innovative Research in Science, Engineering and Technology*, Vol. 5, Issue 5, May 2016.
17. Laad, BAKhare, Chaurasia, "Thermal Analysis of Heat Sink with Fins Of Different Configuration Using Ansys Workbench 14.0", *International Journal Of Engineering Sciences & Research Technology*, volume 5, Issue 6, 2016.
18. Saurabh Pathak, Ravikant, "Thermal Analysis of Fins with Varying Geometry of Different Materials", *IJSRD - International Journal for Scientific Research & Development*, Vol. 4, Issue 03, 2016.
19. Alshabbani, "CFD Simulation of Unsteady State Thermal Analysis for Circular Fins", *Industrial Engineering Letters*, Vol.5, No.12, 2015.
20. Prabisha, Ramesh, "Thermal Performance Evaluation of Heat Sink for Various Fin Profiles", *International Journal of Science, Technology & Management*, Volume No 04, Special Issue No. 01, March 2015.
21. Santosh Kansal, Piyush Laad, "Performance & Thermal Analysis of Heat Sink with Fins of Different Configuration Using CFD", *International Journal of Scientific & Engineering Research*, Volume 6, Issue 6, June-2015.

22. Oswal, Jagtap, Mane, "Factors Affecting on Thermal Performance of Fins & Analysis of Fins with ANSYS Icepak", International Journal of Innovative Research in Science, Engineering and Technology, Vol. 4, Issue 6, June 2015.
23. Shrivastava, Upadhyay, "Thermal Analysis of IC Engine Cylinder Block with Fins Perpendicular to the Axis of Piston Movement", International Journal of Mechanical and Industrial Technology, Vol. 3, Issue 2, pp: 139-149,2016.
24. M. S. Patel, N.M. Vora, "Thermal Analysis of I C Engine cylinder fins array using CFD", International Journal of Advance Engineering and Research Development (IJAERD) Volume 1, Issue 5, May 2014.
25. N. B. Rairker, A. V. Karmankar, R. E. Thombre, "Thermal Analysis of Fin and Tube Heat Exchanger", International Journal of Engineering Research and Applications, Vol. 4, Issue 6, June 2014, pp.01-05.
26. Chaitanya, Suneela Rani, Vijaya Kumar, "Thermal Analysis of Engine Cylinder Fin by Varying Its Geometry and Material", IOSR Journal of Mechanical and Civil Engineering (IOSR-JMCE), Volume 11, Issue 6, 2014, PP 37-44.
27. Chakrabortya, Luharuka, A. Sirkar, "Thermal Analysis of Semicircular Fins Considering Temperature-dependent Thermal Conductivity and Heat Transfer Coefficient", Indian Chemical Engineer, Taylor and Francis, Vol. 56 No. 3 September 2014, pp. 281–293.
28. Laxmikant Chavan, Niranjana Purane, "Thermal Analysis of Pin Fin using Different Materials and Forms", International Journal of Science and Research (IJSR), Volume 4 Issue 12, December 2015.
29. Mohsen Torabi, Yaghoobi, "Thermal Analysis of the Convective-Radiative Fin with A Step Change in Thickness and Temperature Dependent Thermal Conductivity", Journal of Theoretical and Applied Mechanics, 51, 3, pp. 593-602, Warsaw 2013
30. HMT. Revised edition, book, R. K. Rajput

Annexure I

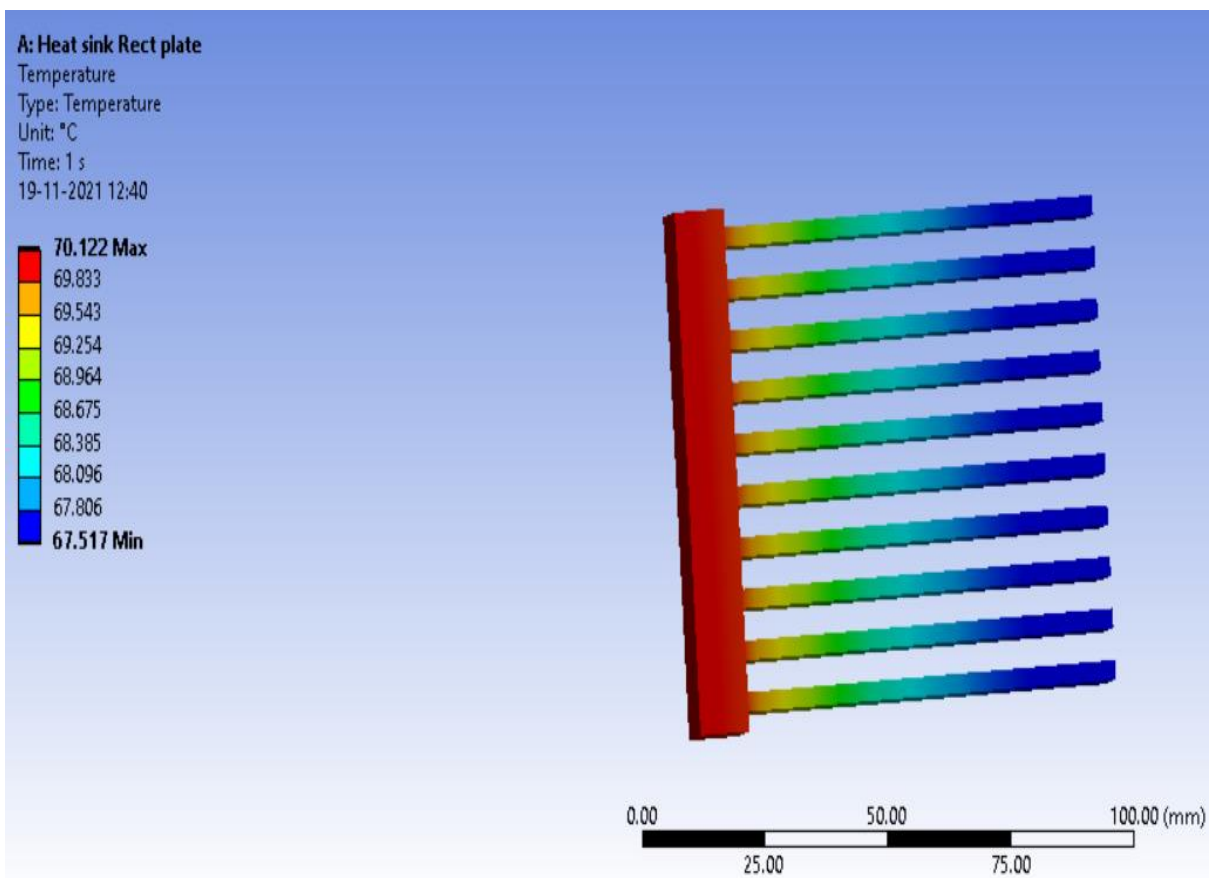

Temperature Distribution of Plate Fins

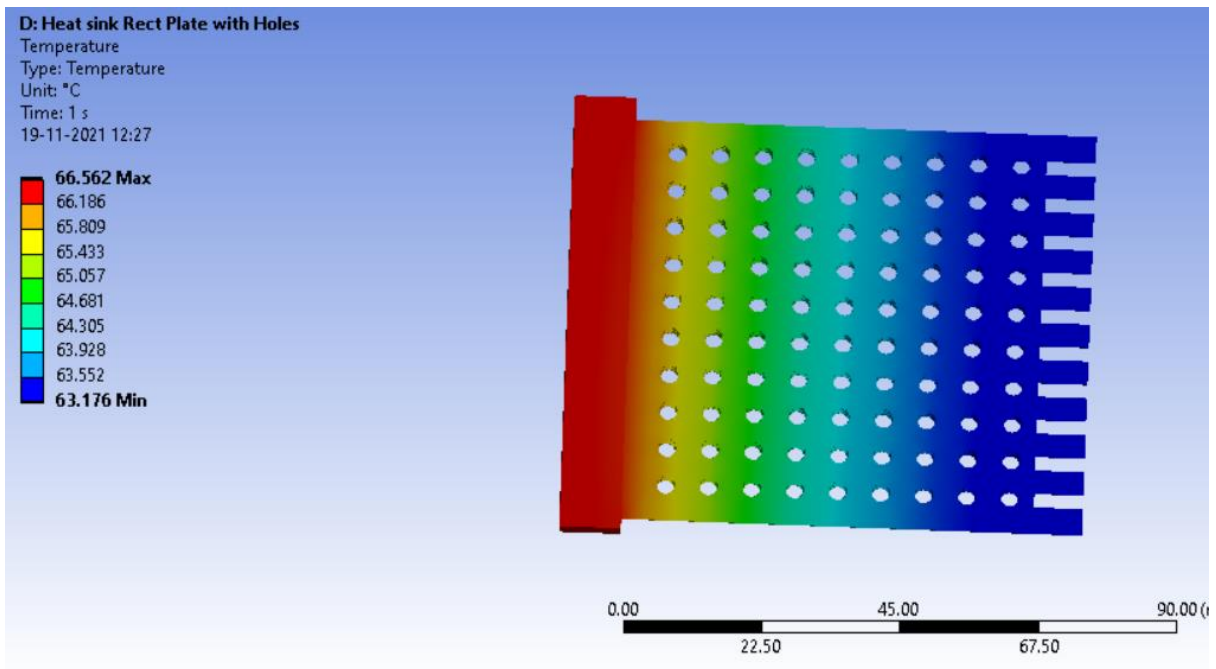

Temperature Distribution of Rectangular plate Fins with holes

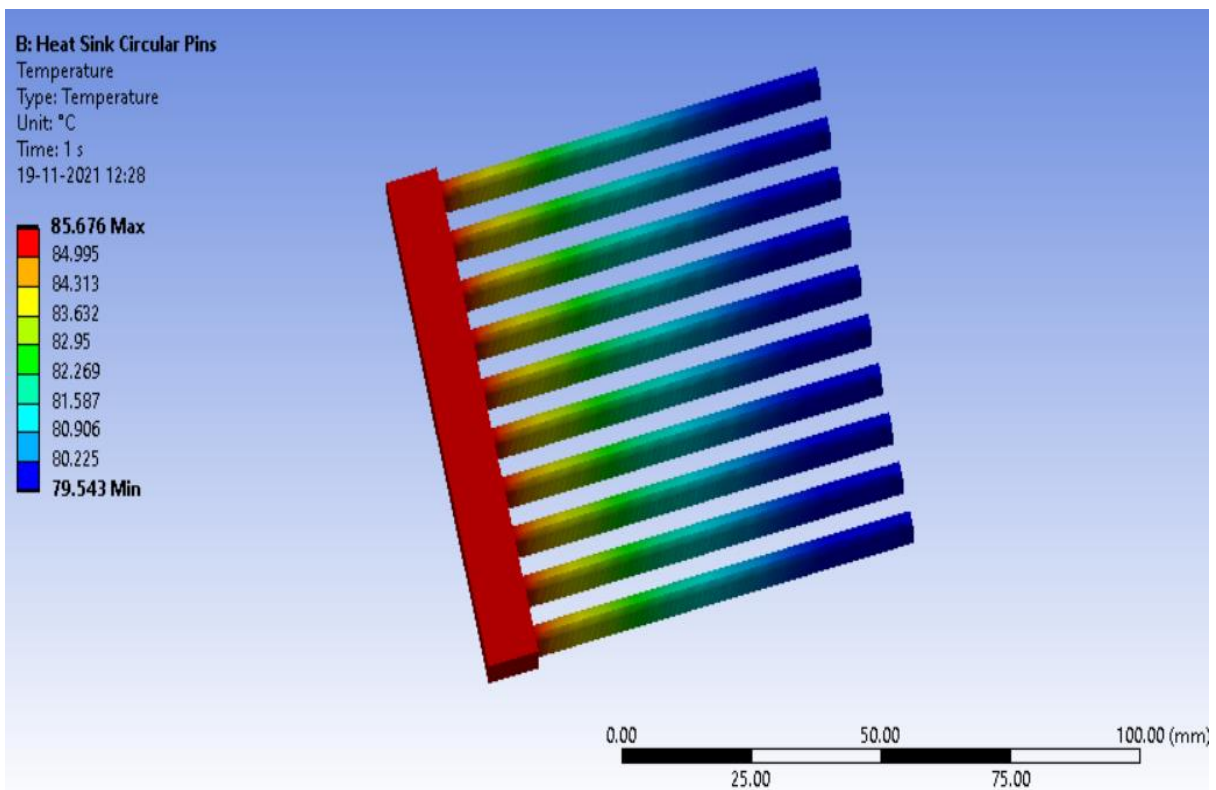

Temperature Distribution of Circular Pin Fins

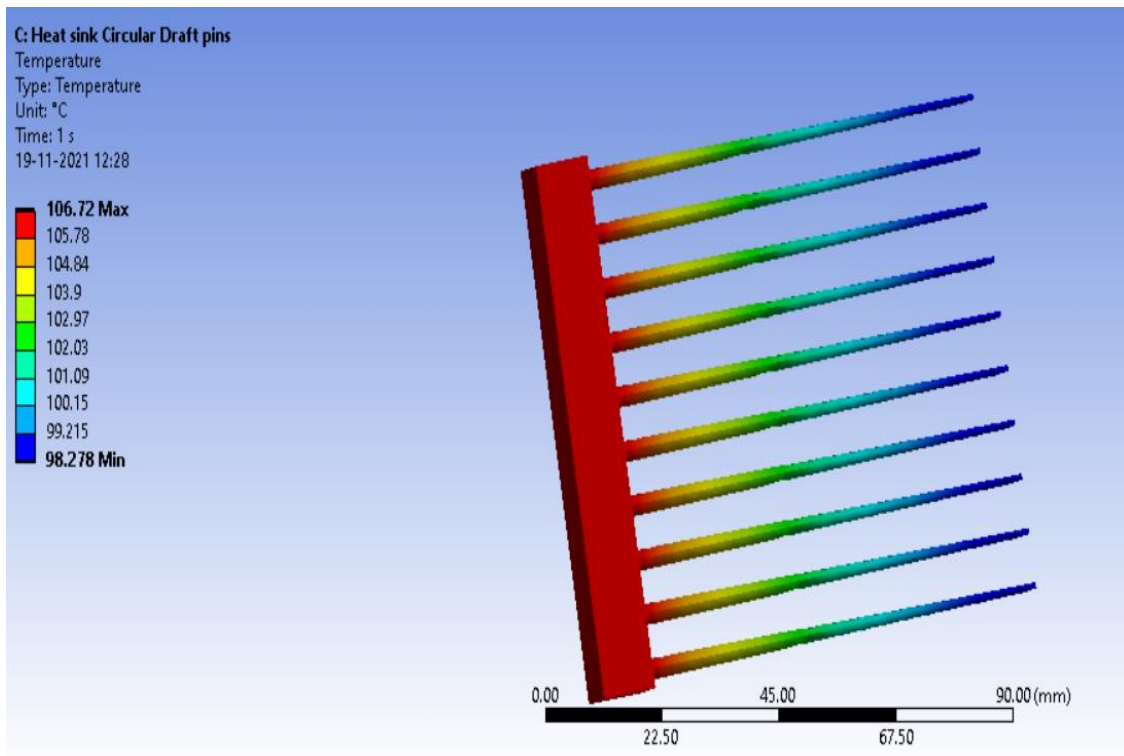

Temperature Distribution of draft conical Pin Fins

➤ **Heat Flux and thermal stress analysis of Fins Models**

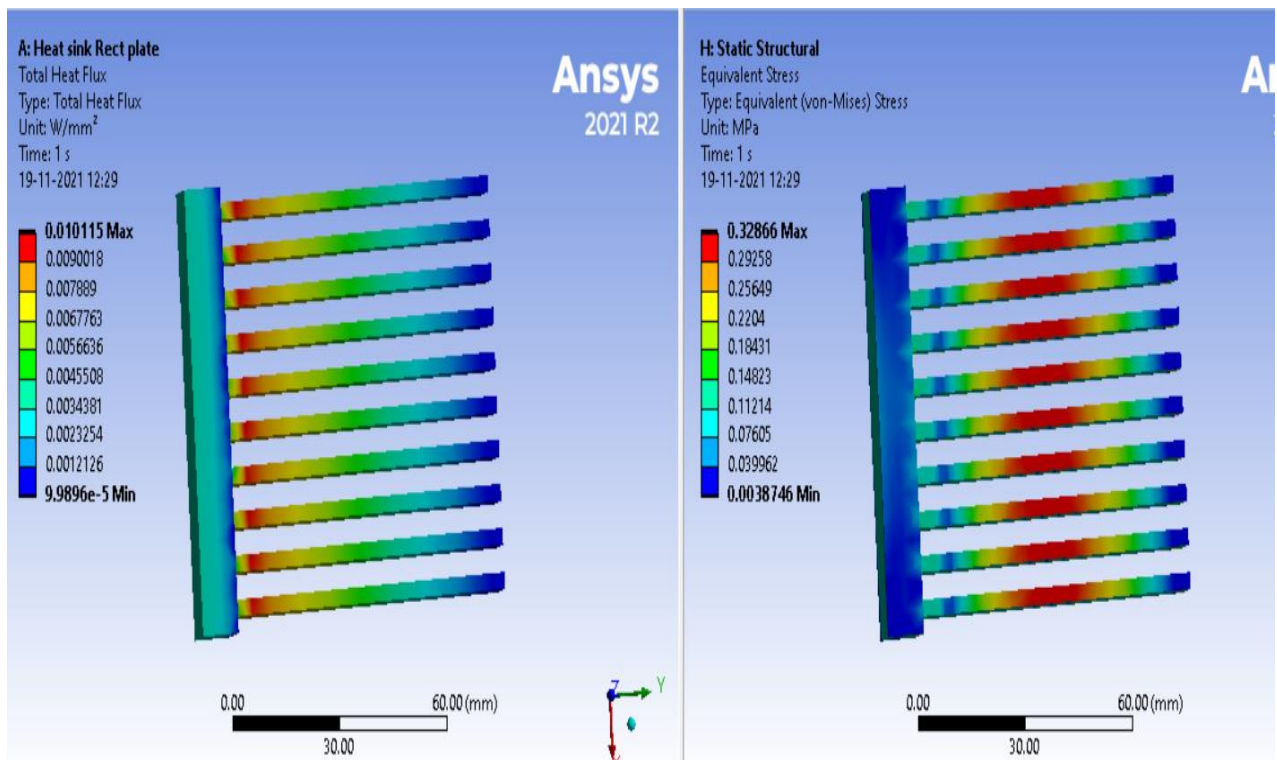

Heat Flux and Stress of Plate Fins

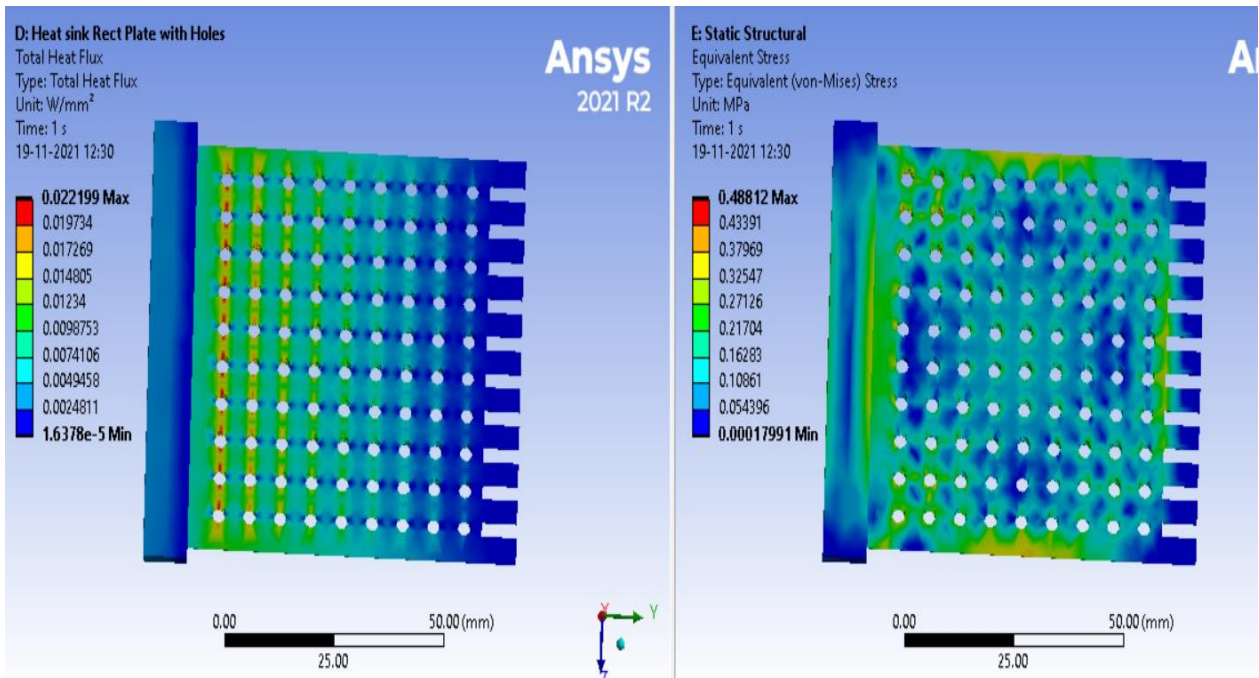

Heat flux of Rectangular plate Fins with holes

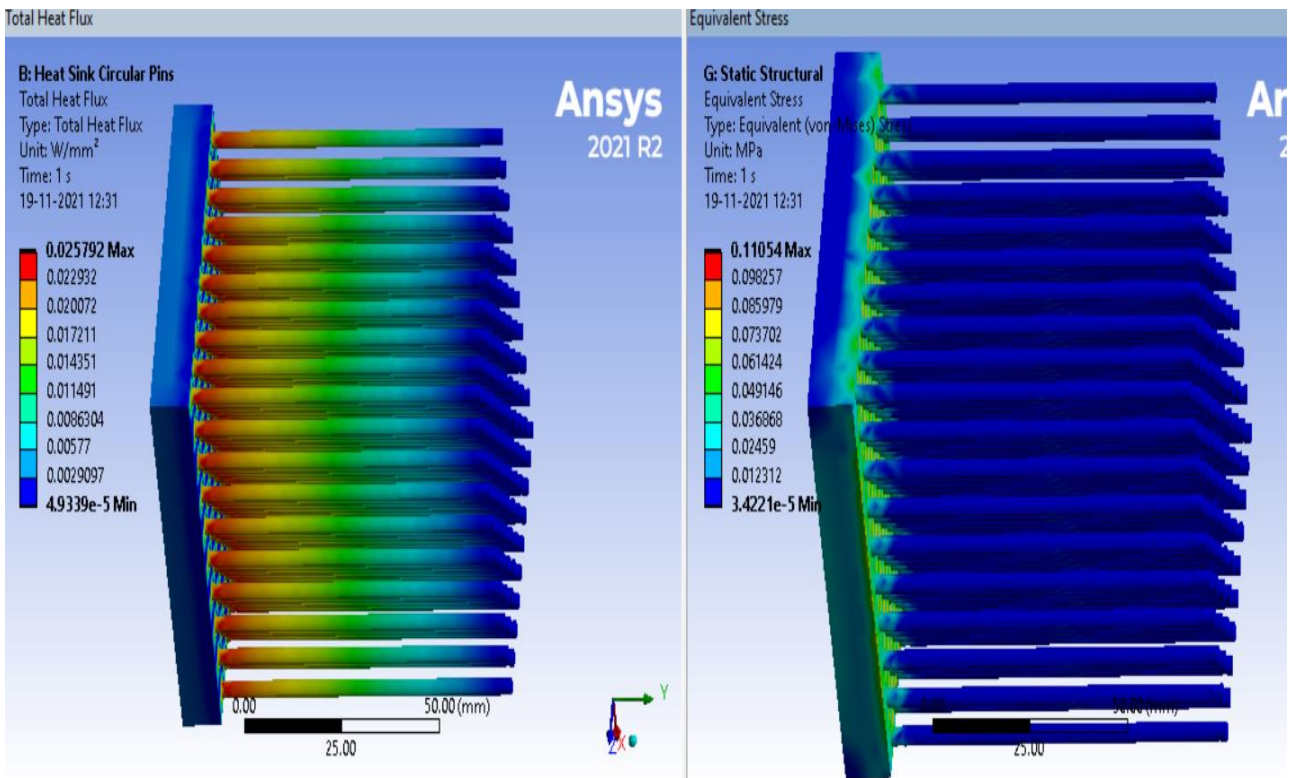

Heat flux and Stress of Circular Pin Fins

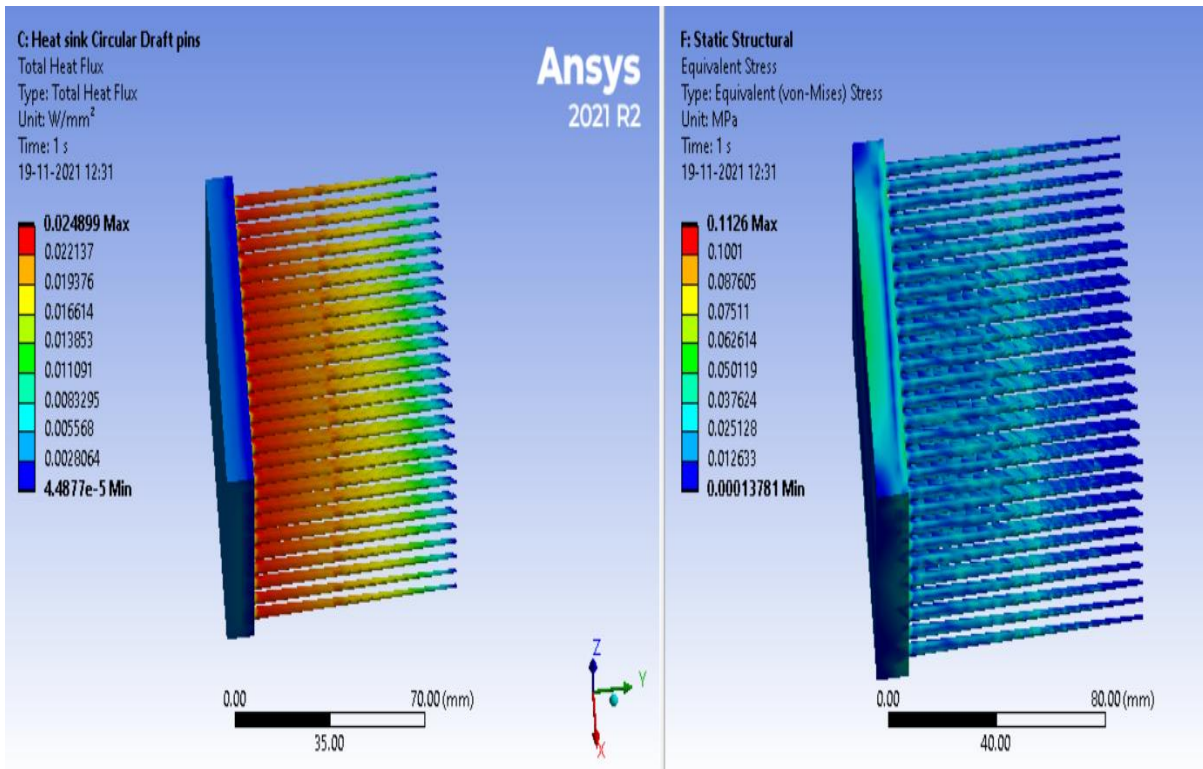

Heat flux and Stress of Circular Pin Fins