

A
Major Project
On
“Effects of Machining Variables on Surface Roughness in
Wire-EDM of AISI D3”

*A Dissertation submitted towards the partial fulfilment of requirements for the
award of the degree*

Of

Master of Engineering
In
Production Engineering
By

Maneesh Kumar Yadav
Roll No. 06/Pro/09
University Roll No. 9053

Under the supervision and guidance of
Dr. VIPIN
(Associate Professor)



**DEPARTMENT OF MECHANICAL AND PRODUCTION
ENGINEERING
DELHI COLLEGE OF ENGINEERING
UNIVERSITY OF DELHI, DELHI-110042
SESSION 2010-11**

CERTIFICATE



DELHI COLLEGE OF ENGINEERING

(Govt. of National Capital Territory of Delhi)

BAWANA ROAD, DELHI – 110042

Date: _____

This is to certify that the project entitled “**Effects of machining variables on surface roughness in wire-EDM of AISI D3**” being submitted by ‘**Maneesh Kumar Yadav**’ (College Roll No 17/E&C/09 & University Roll No- 9053) is a student of Delhi College of Engineering. This work is completed under the guidance and supervision of Dr. Vipin, (Associate Professor) in partial fulfillment of requirements for the award of the Degree of Master of Engineering (Production Engineering) in Mechanical Engineering, from University of Delhi, Delhi. He has completed his work with sincerity and diligence.

The matter embodied in this project has not been submitted for the award of any other degree

Dr. Vipin

(Associate Professor)

**Department of Mechanical
And Production Engineering
Delhi College of Engineering
Delhi-110042**

ACKNOWLEDGEMENT

I take the opportunity to express my heartfelt adulation and gratitude to my supervisor, Dr. Vipin Kumar, Asst. Professor, Mechanical Engineering Department, Delhi College of Engineering, Delhi for his unreserved guidance, constructive suggestions, thought provoking discussions and unabashed inspiration in nurturing this thesis work. It has been a benediction for me to spend many opportune moments under the guidance of the perfectionist at the acme of professionalism. The present work is a testimony to his alacrity, inspiration and ardent personal interest, taken by him during the course of this thesis work in its present form.

I am grateful to Dr. B.D. Pathak, Professor and Head, Mechanical and Production Engineering Department Delhi College of Engineering, Delhi for providing help to carry out the thesis work.

I cannot close these prefatory remarks without expressing my deep sense of gratitude and reverence to my dear parents for their blessings and endeavour to keep my moral high throughout the period of my work. I want to express my sincere thanks to all those who directly or indirectly helped me at various stages of the thesis work.

Above all, I express my indebtedness to the “**ALMIGHTY**” for all His blessing and kindness.

Maneesh Kumar Yadav
Roll No. 06/pro/09
University Roll No. 9053
Department of Mechanical
And Production Engineering
Delhi College of Engineering
Delhi-110042

ABSTRACT

Accompanying the development of industry, the demands for alloy materials having high hardness, toughness and impact resistance are increasing. Wire EDM machines are used to cut conductive metals of any hardness or that are difficult or impossible to cut with traditional methods. The machines also specialize in cutting complex contours or fragile geometries that would be difficult to be produced using conventional cutting methods. Machine tool industry has made exponential growth in its manufacturing capabilities in last decade but still machine tools are not utilized at their full potential. This limitation is a result of the failure to run the machine tools at their optimum operating conditions. The problem of arriving at the optimum levels of the operating parameters has attracted the attention of the researchers and practicing engineers for a very long time.

The literature survey has revealed that a little research has been conducted to obtain the optimal levels of machining parameters that yield the best machining quality in machining of difficult to machine materials like die steel AISI D3. The die steel AISI D3 is extensively used for hot-work forging, extrusion, manufacturing punching tools, mandrels, mechanical press forging die, plastic mould and die-casting dies, aircraft landing gears, helicopter rotor blades and shafts, etc. The consistent quality of parts being machined in wire electrical discharge machining is difficult because the process parameters cannot be controlled effectively. These are the biggest challenges for the researchers and practicing engineers. Manufacturers try to ascertain control factors to improve the machining quality based on their operational experiences, manuals or failed attempts. Keeping in view the applications of material AISI D3 die steel, it has been selected and has been machined on wire-cut EDM (EZEECUT PLUS WIRECUT EDM) of Electronica Machine Tools Limited.

The objective of the present work was to investigate the effects of the various WEDM process parameters on the surface roughness and to obtain the optimal sets of process parameters so that the quality of machined parts can be optimized. The working ranges and levels of the WEDM process parameters are found using one factor at a time approach. The linear regression analysis has been used to investigate the effects of the WEDM process parameters and subsequently to predict sets of optimal parameters for best surface finish.

CONTENTS

CERTIFICATE	i
ACKNOWLEDGEMENT	ii
ABSTRACT	iii
CONTENTS	v
LIST OF FIGURES	vii
LIST OF TABLES	viii
NOMENCLATURE	x
CHAPTER 1: INTRODUCTION	1-15
1.1 HISTORY OF WIRE-EDM	1
1.2 PROBLEM STATEMENT	2
1.3 DISCRIPTION AND BACKGROUND OF DIE STEEL	3
1.3.1 Different Type of die steel	4
1.4 DISCUSSION ON WORKPICE MATERIAL(AISI D3):	9
1.5 BASIC PRINCIPLES OF WIRE ELECTRICAL DISCHAGE MACHINING	10
1.6 DEFINITION OF TERMS	13
CHAPTER 2: BACKGROUND AND REVIEW OF LITERATURE	16 - 27
2.1 INTRODUCTION	16
2.2 OBJECTIVE OF THE PRESENT WORK	27
CHAPTER 3: EXPERIMENTAL SET-UP AND PROCESS PARAMETER SELECTION	28 - 38
3.1 MACHINE TOOL	28
3.2 WORK PIECE MATERIAL	29
3.3 PREPARATION OF SPECIMENS	31
3.4 EXPERIMENTATION	33
3.5 SELECTION OF PROCESS PARAMETERS	33-35
3.5.1 Pulse on Time	33
3.5.2 Pulse off Time	34
3.5.3 Peak Current	35

3.5.4	Spark Gap Set Voltage	35
3.5.5	Wire Feed	35
3.6.	EXPERIMENT DESIGN	36
CHAPTER 4: EXPERIMENTAL DESIGN METHODOLOGY		39-40
4.1.	Regression analysis:	39
CHAPTER 5: RESULT AND DISCUSSION		41 - 61
5.1	INTRODUCTION	41
5.1.1	Response table	41
5.2	EFFECT OF WIRE FEED RATE ON SURFACE ROUGHNESS	42
5.3	EFFECT OF PULSE ON TIME ON SURFACE ROUGHNESS	46
5.4	EFFECT OF SPARK GAP VOLTAGE ON SURFACE ROUGHNESS	48
5.5	EFFECT OF SPARK GAP VOLTAGE OVER WIRE FEED RATE	50
5.6	EFFECT OF PULSE ON TIME OVER WIRE FEED RATE	54
5.7	EFFECT OF PULSE ON TIME ON GAP VOLTAGE	61
CHAPTER 6: CONCLUSION		62
REFERNCES		63-65

LIST OF FIGURES

Number	Title	Page No
Figure 1.1	Ezeecut Plus Wirecut EDM	2
Figure 1.2	Evolution of a single spark in the EDM process	11
Figure1.3 (a)	Conventional 2D Wire EDM operation	12
Figure1.3 (b)	Enlarge view of the wire and workpiece	12
Figure 1.4	Pictorial View of WEDM Machine Tool	13
Figure 3.1	Machine Floor Plan	29
Figure 3.2	Specimens is shown mounted on the WEDM machine	31
Figures 3.3a	Cutting Specimen dimension in mm	32
Figures 3.3b	View of cutting specimen	32
Figures 3.4	Process Parameters and Performance Measures of WEDM	34
Figures 3.5	Series of Electrical Pulses at the Inter Electrode Gap	35
Figure 3.6	Taylor Hobson instrument	37
Figure 5.1	Effect of wire feed rate on surface roughness	43
Figure 5.2	Effect of wire feed rate on surface roughness	44
Figure 5.3	Effect of wire feed rate on surface roughness	45
Figure 5.4	Effect of Pulse on Time on surface roughness	47
Figure 5.5	Effect of gap voltage on surface roughness	49
Figure 5.6	Effect of gap voltage over wire feed rate at $T_{on}=30$	51
Figure 5.7	Effect of gap voltage over wire feed rate at $T_{on}=50$	52
Figure 5.8	Effect of gap voltage over wire feed rate at $T_{on}=70$	53
Figure 5.9	Effect of gap voltage over wire feed rate at $V_g=25$	55
Figure 5.10	Effect of gap voltage over wire feed rate at $V_g=50$	56
Figure 5.11	Effect of gap voltage over wire feed rate at $V_g=75$	57
Figure 5.12	Effect of pulse on time over gap voltage at $feed=25$	59
Figure 5.13	Effect of pulse on time over gap voltage at $feed=50$	60
Figure 5.14	Effect of pulse on time over gap voltage at $feed=75$	61

LIST OF TABLES

Number	Title	Page No
Table 1.1	Material Composition of AISI D2	4
Table 1.2	Material Composition of AISI D3	5
Table 1.3	Material Composition of AISI D4	6
Table 1.4	Material Composition of AISI D5	7
Table 1.5	Material Composition of AISI D7	8
Table 3.1	Chemical Composition of the Material	30
Table 3.2	Variable and respective reading	36
Table 3.3	Set of experiment with their Ra value	38
Table 5.1	Response table	41
Table 5.2	Performance Measures for Wire Feed at $V_g=25$ volt	43
Table 5.3	Performance Measures for Wire Feed at $V_g=50$ volt	44
Table 5.4	Performance Measures for Wire Feed at $V_g=75$ volt	45
Table 5.5	Performance Measures for Pulse on Time at $F=60$ units	46
Table 5.6	Performance Measures for Spark Gap Set Voltage	48
Table 5.7	Variation in feed at different surface roughness when gap voltage changes	51
Table 5.8	Variation in feed at different surface roughness when gap voltage changes	52
Table 5.9	Variation in feed at different surface roughness when gap voltage changes	53
Table 5.10	Variation in feed at different surface roughness when pulse on time changes	55
Table 5.11	Variation in feed at different surface roughness when pulse on time changes	56
Table 5.12	Variation in feed at different surface roughness when pulse on time changes	57

Table 5.13	Variation in Pulse on time at different surface roughness when gap voltage change	59
Table 5.14	Variation in Pulse on time at different surface roughness when gap voltage changes	60
Table 5.15	Variation in Pulse on time at different surface roughness when gap voltage changes	61

NOMENCLATURE

Symbol	Description
Ton	Pulse on time
Toff	Pulse off time
V _g	Spark gap set voltage
I _p	Peak current
DF, DOF	Degree of freedom
WFR	Wire feed rate
Gp	Group pulse
WEDM	Wire-electric discharge machining
AISI	American Institute of Steel and Iron
ASTM	American School of Testing Material
SAE	Society of American engineer
UNS	Unified Numbering System
CNC	Computer Numerical Control
SR	Surface roughness
Ra	Arithmetic Mean Roughness
SF	Surface Finish
DTU	Delhi Technological University
ANOVA	Analysis of variance
CWEDT	Cylindrical Wire Electrical Discharge Turning
DOE	Design of Experiment
RSM	Response Surface Methodology
WC	Tungsten Carbide
RC	Resistance–Capacitance
EES	Engineering Equation Solver
EDAX	Electro Dispersive X-ray Spectroscopy
WCS	Work Co-ordinate System
Column1	Wire feed rate (WFR)
Column2	Pulse on time (Ton)
Column3	Spark gap Voltage (Vg)
Column4	Surface Roughness (Ra)

1.6. DEFINITION OF TERMS

Accuracy – Degree of conformity to a specification.

Arc – The flow of electricity across the gap between the electrodes and the workpiece.

Arc Gap-The space between the electrode and the workpiece where EDM occurs.

Contamination – Particles and debris found in the dielectric fluid that reduces its effectiveness.

CTE– Coefficient of Thermal Expansion

Discharge – Controlled flow of current across a gap causing a spark.

Deionization – Process of removing ions.

Deionized Water – Water that has had the ions removed.

Dielectric Fluid – A liquid of low conductivity, which acts as a coolant to solidify particles and then flushes them out of the working gap.

Dielectric System – Dielectric liquid is circulated to remove contamination and control debris size in the working gap during machining. This system is composed of a pump, filter, hoses, tank, and gauges.

EDM – Acronym for Electrical Discharge Machine or Electrical Discharge Machining. EDM is a process for eroding and removing material by transient action of electric spark on electrically conductive materials.

Electrode – Electrically conductive tool used to carry current to the workpiece material.

Electrode Wear – The amount of electrode material consumed during the EDM process.

Heat Affected Zone– A shallow layer in the workpiece that has been thermally affected by the arc, which changes its properties.

Ionization – Occurs when the dielectric fluid becomes conductive after being subjected to high voltage.

Material Removal Rate– The volume of workpiece that is removed in a given unit of time (e.g., cubic inches per hour).

Parallelism – Running in the same direction in an equal and consistent manner.

Precision – Consistency of results in repeated experiments.

Pulse Generator – Creates a surge of electrical current.

RMS – Roughness is indicated by the root-mean-square (RMS) average, which is the square root of the average value squared, of a series of measurements of deviations from the roughness centerline.

Speed – The advance rate of the workpiece perpendicular to the wire, measured in inches per minute.

Tab- A small insert, addition, or remnant; **Web**

Tensile Strength– The maximum engineering stress in tension, which may be sustained without fracture; often termed ultimate (tensile) strength.

Thermal Conductivity–For steady-state heat flow, the proportionality constant between the heat flux and the temperature gradient. Also, a parameter characterizing the ability of a material to conduct heat.

Tolerance – The permissible deviation from an ideal.

WEDM – An EDM process wherein the electrode is a wire that cuts through the workpiece and is renewed constantly to avoid rupture.

Working Gap – The gap between the electrode and the workpiece

CHAPTER 1

INTRODUCTION

1.1 CONVENTIONAL AND NON-CONVENTIONAL MACHINING:

1.1.1 Conventional Machining:

Conventional machining is a collection of material-working processes in which power-driven machine tools, such as saws, lathes, milling machines, and drill presses, are used with a sharp cutting tool to mechanically cut the material to achieve the desired geometry. Machining is a part of the manufacture of almost all metal products, and it is common for other materials, such as wood and plastic, to be machined. A person who specializes in machining is called a machinist. A room, building, or company where machining is done is called a machine shop. Much of modern day machining is controlled by computers using computer numerical control (CNC) machining. Machining can be a business, a hobby, or both.

The precise meaning of the term "machining" has evolved over the past 1.5 centuries as technology has advanced. During the machining age it referred to the "traditional" machining process such as turning, boring, drilling, milling, broaching, sawing, shaping, planing, reaming, and tapping or sometimes to grinding. Since the advent of new technologies such as electrical discharge machining, electrochemical machining, electron beam machining, photochemical machining, and ultrasonic machining, the retronym "conventional machining" can be used to differentiate the classic technologies from the newer ones. The term "machining" without qualification usually implies conventional machining. Since the rise of additive manufacturing (most especially since the 2000s), material-adding techniques have begun to fulfil some of the same part-creation needs that were traditionally filled with machining (which is about material removal). Therefore, in recent years material-removing processes (traditional machining and the newer types) are often being retronymously classified, in thought and language, as subtractive manufacturing methods. In narrow contexts, additive and subtractive methods may compete with each other. In the broad context of entire industries, their relationship is complementary

1.1.1.2 Principle Machining Operations:

The three principal machining processes are classified as turning, drilling and milling. Other operations falling into miscellaneous categories include shaping, planing, boring, broaching and sawing.

- Turning operations are operations that rotate the workpiece as the primary method of moving metal against the cutting tool. Lathes are the principal machine tool used in turning.
- Milling operations are operations in which the cutting tool rotates to bring cutting edges to bear against the workpiece. Milling machines are the principal machine tool used in milling.
- Drilling operations are operations in which holes are produced or refined by bringing a rotating cutter with cutting edges at the lower extremity into contact with the workpiece. Drilling operations are done primarily in drill presses but sometimes on lathes or mills.
- Miscellaneous operations are operations that strictly speaking may not be machining operations in that they may not be swarf producing operations but these operations are performed at a typical machine tool. Burnishing is an example of a miscellaneous operation. Burnishing produces no swarf but can be performed at a lathe, mill, or drill press.

An unfinished workpiece requiring machining will need to have some material cut away to create a finished product. A finished product would be a workpiece that meets the specifications set out for that workpiece by engineering drawings or blueprints. For example, a workpiece may be required to have a specific outside diameter. A lathe is a machine tool that can be used to create that diameter by rotating a metal workpiece, so that a cutting tool can cut metal away, creating a smooth, round surface matching the required diameter and surface finish. A drill can be used to remove metal in the shape of a cylindrical hole. Other tools that may be used for various types of metal removal are milling machines, saws, and grinding machines

1.1.2 Non-Conventional Machining:

Since beginning of the human race, people have evolved tools and energy sources to power these tools to meet the requirements for making the life easier and enjoyable.

In the early stage of mankind, tools were made of stone for the item being made. When iron tools were invented, desirable metals and more sophisticated articles could be produced. In twentieth century products were made from the most durable and consequently, the most unmachinable materials. In an effort to meet the manufacturing challenges created by these materials, tools have now evolved to include materials such as alloy steel, carbide, diamond and ceramics.

A similar evolution has taken place with the methods used to power our tools. Initially, tools were powered by muscles; either human or animal. However as the powers of water, wind, steam and electricity were harnessed, mankind was able to further extend manufacturing capabilities with new machines, greater accuracy and faster machining rates.

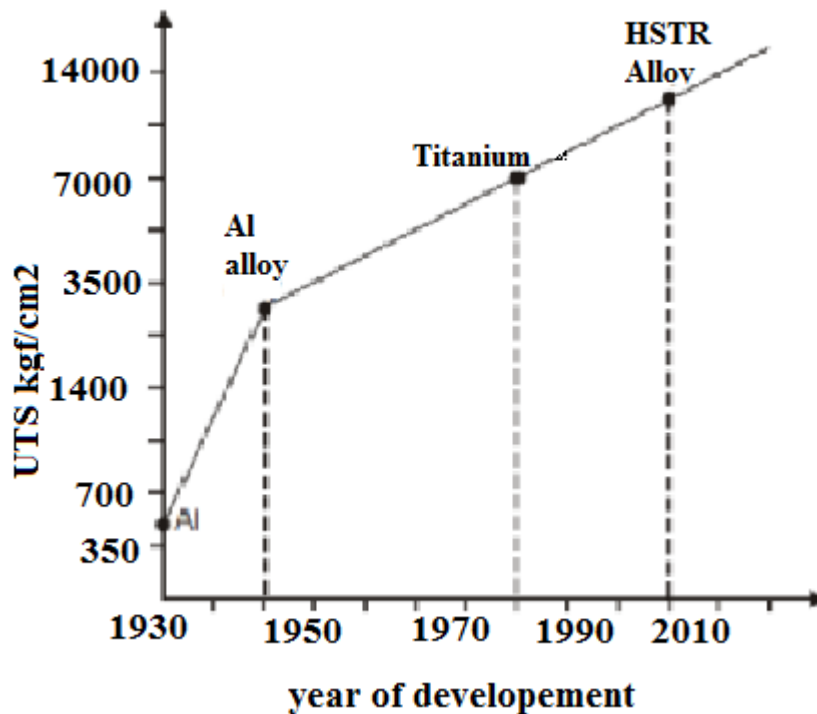

Figure 1.1: Trend of increase of mechanical strength.

Every time new tools, tool materials, and power sources are utilized, the efficiency and capabilities of manufacturers are greatly enhanced. Since 1940's, a revolution in manufacturing has been taking place that once again allows manufactures to meet the demands imposed by increasingly sophisticated designs and durable but in many cases nearly unmachinable, materials.

In the figure 1.1, Merchant had displayed the gradual increase in strength of material with year wise development of material in aerospace industry. This manufacturing revolution is now, as it has been in the past, centred on the use of new tools and new forms of energy. The result has been the introduction of new manufacturing processes used for material removal, forming and joining, known today as non-traditional manufacturing processes.

The conventional manufacturing processes in use today for material removal primarily rely on electric motors and hard tool materials to perform tasks such as sawing, drilling and broaching. Conventional forming operations are performed with the energy from electric motors, hydraulics and gravity. Likewise, material joining is conventionally accomplished with thermal energy sources such as burning gases and electric arcs.

In contrast, non-traditional manufacturing processes harness energy sources considered unconventional by yesterday's standards. Material removal can now be accomplished with electrochemical reaction, high temperature plasmas and high-velocity jets of liquids and abrasives. Materials that in the past have been extremely difficult to form, are now formed with magnetic fields, explosives and the shock waves from powerful electric sparks. Material-joining capabilities have been expanded with the use of high-frequency sound waves and beams of electrons and coherent light.

During the last 55 years, over 20 different non-traditional manufacturing processes have been invented and successfully implemented into production.

1.1.2.1 Classification of Advanced Machining Processes

These non-conventional processes can be classified into various groups according to the basic requirements which are as follows:

1. Type of energy required, namely, mechanical, electrical, chemical etc.
2. Basic mechanism involved in the processes, like erosion, ionic dissolution, vaporisation etc.

3. Source of immediate energy required for material removal, namely, hydrostatic pressure, high current density, high voltage, ionised material, etc.
4. Medium for transfer of those energies, like high velocity particles, electrolyte, electron, hot gases, etc.

On the basis of above requirements, the various processes may be classified as shown below.

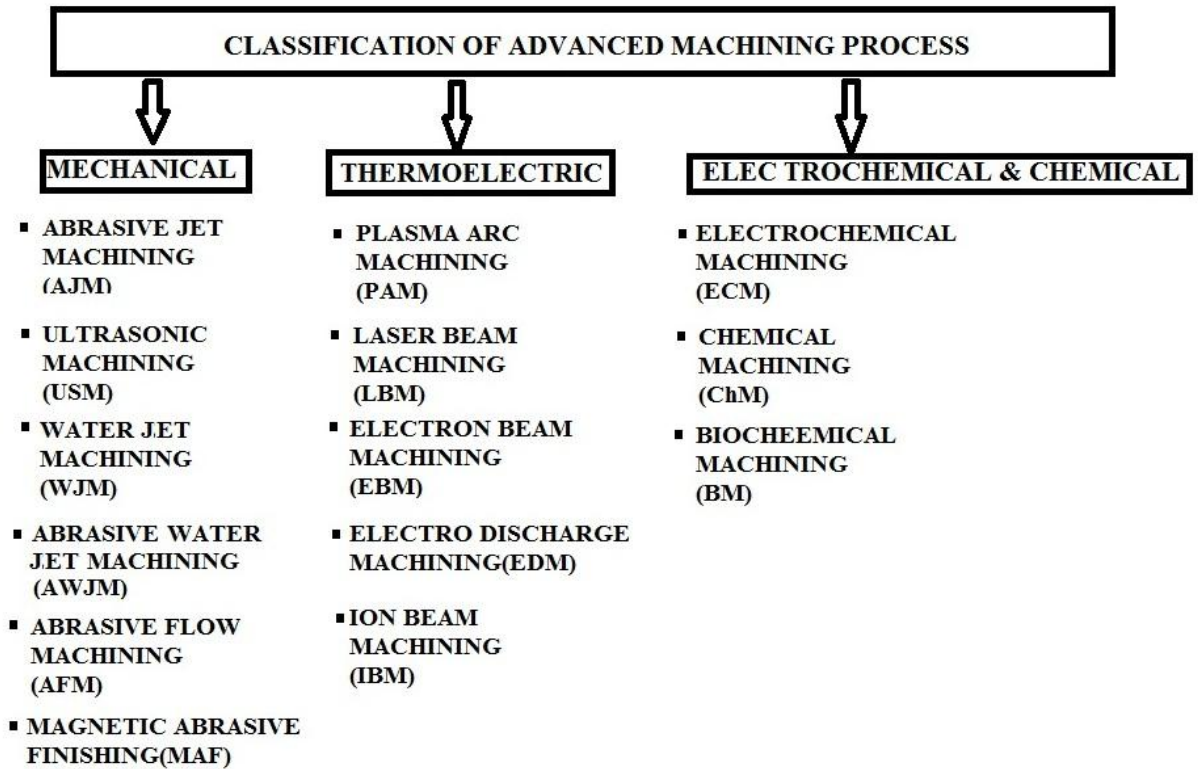

Figure 1.2 Classification of Advanced Machining Process.

1.2 DEVELOPMENT OF EDM AND WIRE-EDM:

Wire electrical discharge machining (WEDM) is a widely accepted non-traditional material removal process used to manufacture components with intricate shapes and profiles. It is considered as a unique adaptation of the conventional EDM process, which uses an electrode to initialize the sparking process. However, WEDM utilizes a continuously travelling wire electrode made of thin copper, brass, molybdenum or tungsten of diameter 0.05–0.3 mm, which is capable of achieving very small corner radii. The wire is kept in tension using a mechanical

tensioning device reducing the tendency of producing inaccurate parts. During the WEDM process, the material is eroded ahead of the wire and there is no direct contact between the workpiece and the wire, eliminating the mechanical stresses during machining. In addition, the WEDM process is able to machine exotic and high strength and temperature resistive (HSTR) materials and eliminate the geometrical changes occurring in the machining of heat-treated steels.

WEDM was first introduced to the manufacturing industry in the late 1960s. The development of the process was the result of seeking a technique to replace the machined electrode used in EDM. In 1974, D.H. Dulebohn applied the optical-line follower system to automatically control the shape of the component to be machined by the WEDM process [8]. By 1975, its popularity was rapidly increasing, as the process and its capabilities were better understood by the industry. It was only towards the end of the 1970s, when computer numerical control (CNC) system was initiated into WEDM that brought about a major evolution of the machining process. As a result, the broad capabilities of the WEDM process were extensively exploited for any through-hole machining owing to the wire, which has to pass through the part to be machined. The common applications of WEDM include the fabrication of the stamping and extrusion tools and dies, fixtures and gauges, prototypes, aircraft and medical parts, and grinding wheel form tools.

1.3 PROBLEM STATEMENT

WEDM is a rapidly-growing machining method used for cutting high-precision metallic parts from hard materials. However, it is a challenge to cut small precision parts from a variety of materials, especially when cutting very thin parts.

The primary objective of this study is to determine how parameter such as wire feed rate, pulse on time, and voltage gap are effect the surface finish of AISI D3 die steel. Figure 1.1 shows the EZEECUT PLUS WIRECUT EDM machine which is used for cutting during each of the experiments.



Figure 1.3: EZEECUT PLUS WIRECUT EDM

1.4 DISCRPTION AND BACKGROUND OF DIE STEEL

Die-making industry is very important to down-stream industries. Any technological changes in the die-making industry surely affect those down-stream manufacturing. One of those technological developments is novel materials for making various kinds of dies. New die steels have been continuously introduced to the die manufacturers, and affect their die-making processes or their die quality. New materials with high hardness and toughness, such as die and tool steels, are being developed. These materials are difficult to be machined by conventional manufacturing techniques such as milling, drilling, and turning. Hence, non-traditional machining processes including electrochemical machining, ultrasonic machining, and electrical discharge machining (EDM) are employed. Wire electrical discharge machining (wire-EDM), a

form of EDM, is a non-traditional machining method that is widely used to pattern tool steels for die manufacturing. Wire-EDM uses electro-thermal mechanisms to cut electrically conductive material.[15]

New materials (like AISI D3/D4/D5 etc.) with high hardness and toughness, such as die and tool steels, are being developed. These materials are difficult to be machined by conventional manufacturing techniques such as milling, drilling, and turning. Hence, non-traditional machining processes including electrochemical machining, ultrasonic machining, and electrical discharge machining (EDM) are employed. Wire electrical discharge machining (wire-EDM), a form of EDM, is a non-traditional machining method that is widely used to pattern tool steels for die manufacturing. Wire-EDM uses electro-thermal mechanisms to cut electrically conductive material.

1.5 BASIC PRINCIPLES OF WIRE ELECTRICAL DISCHARGE MACHINING [1]

The following description explains the theory behind the generation of spark erosion in the EDM process. While several theories of how EDM works have been advanced over the years, most of the evidence supports the thermoelectric model. The nine illustrations in Figure 1.2 are to show what is believed to happen during the generation of a single spark in the EDM process. Graphs at the bottom of each illustration show how the voltage and current change from each step. In all the diagrams, the wire electrode is the upper dark material of positive charge and the workpiece is the lower jagged part that is negatively charged. The dielectric fluid in the machining gap separates these two surfaces.

Figure 1.2(a) shows what happens with the wire first comes near the workpiece. The dielectric fluid between them provides an insulator to keep electrical charge from flowing from one surface to another. However, as the potential difference increases between the surfaces, the dielectric fluid can break down and become ionic (electrically conductive). The electrical field is strongest at the point where the distance between the surfaces is minimal; thus the spark will occur at this location. Note the voltage has increased, but no current is flowing because of the presence of the dielectric fluid.

Next as shown in Figure 1.2(b), the number of ionic particles increases, making the insulating properties of the dielectric fluid begin to decrease along a narrow channel at the high point. Voltage will reach its peak, but current is still zero.

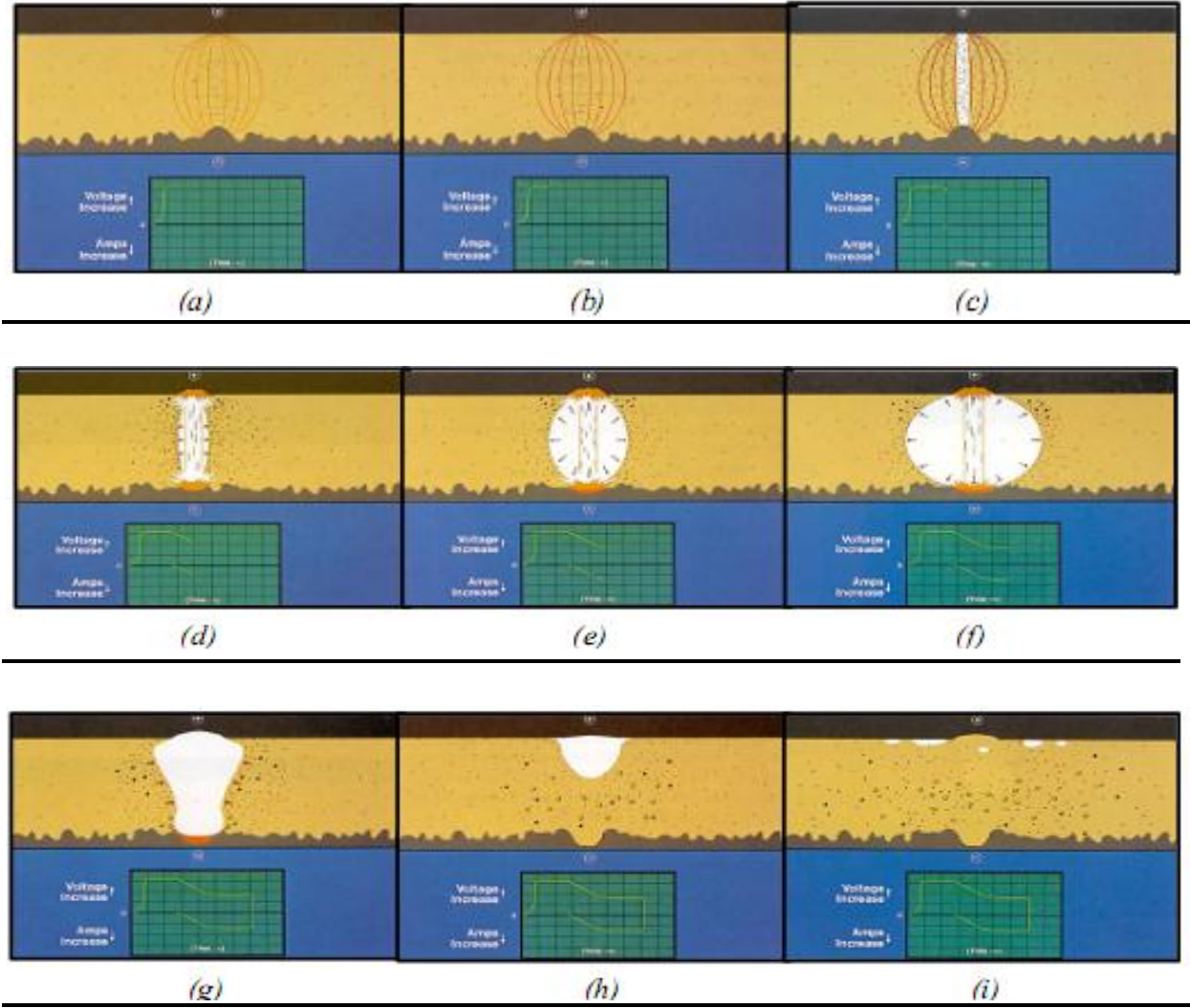

Figure 1.2: Evolution of a single spark in the EDM process

Figure 1.2(c) shows that a current has established, causing the voltage to decrease. Figure 1.2(d) shows that the voltage is continuing to drop as current continues to increase. The heat builds up rapidly, causing some of the fluid, workpiece, and electrode to vaporize. A discharge channel begins to form between the electrode and workpiece.

Figure 1.2(e) depicts a vapor bubble trying to expand outward, but a rush of ions towards the discharge channel limits its expansion. The intense electro-magnetic field that has built up in the channel attracts these ions.

Figure 1.2(f) is during the end of the time when the voltage is on. Here the current and voltage have stabilized. The heat and pressure inside the bubble have reach maximum and some metal is being removed. The metal directly under the discharge column is in molten state, but is held in place by the pressure of the vapor bubble.

Figures 1.2(g) 1.2(h), and 1.2(i) show what happens during the time when no voltage is applied. Both voltage and current go to zero, which causes the temperature and pressure to rapidly decrease in the vapor bubble causing it to collapse. This collapsing bubble allows the molten material to be expelled from the surface of the workpiece. Fresh dielectric fluid rushes in, flushing the debris away and quenching the surface of the workpiece. Unexpelled molten metal solidifies back to the surface to form what is known as the recast layer. This complete process of voltage on and off time comprises the EDM spark cycle.

Wire EDM, as shown in Figure 1.3(a), uses a traveling brass wire, ranging from 0.02 to 0.40 mm in diameter, as the electrode. Continuous electrical sparks, Figure 1.3(b), are generated between the wire and workpiece for material removal. By using computer numerical control, the thin wire is guided in the X and Y directions to cut a precise shape in the workpiece.

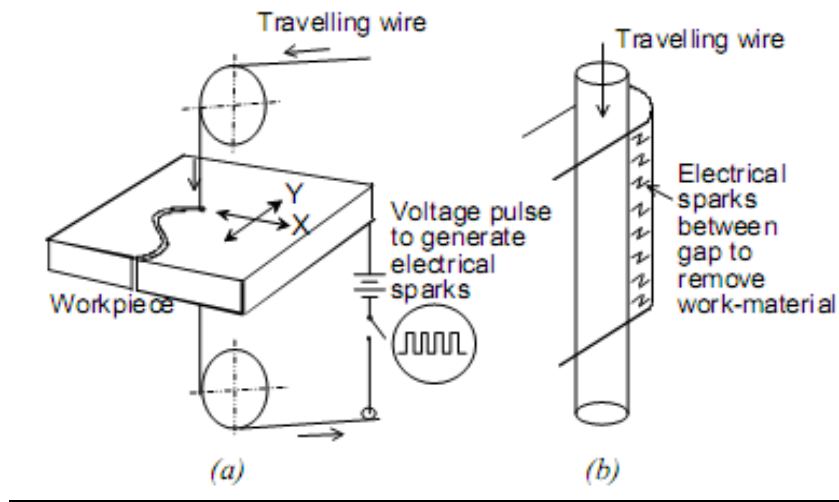

Figure 1.3:-The Wire EDM Process (a) Conventional 2D Wire EDM operation

(b) Enlarge view of the wire and workpiece

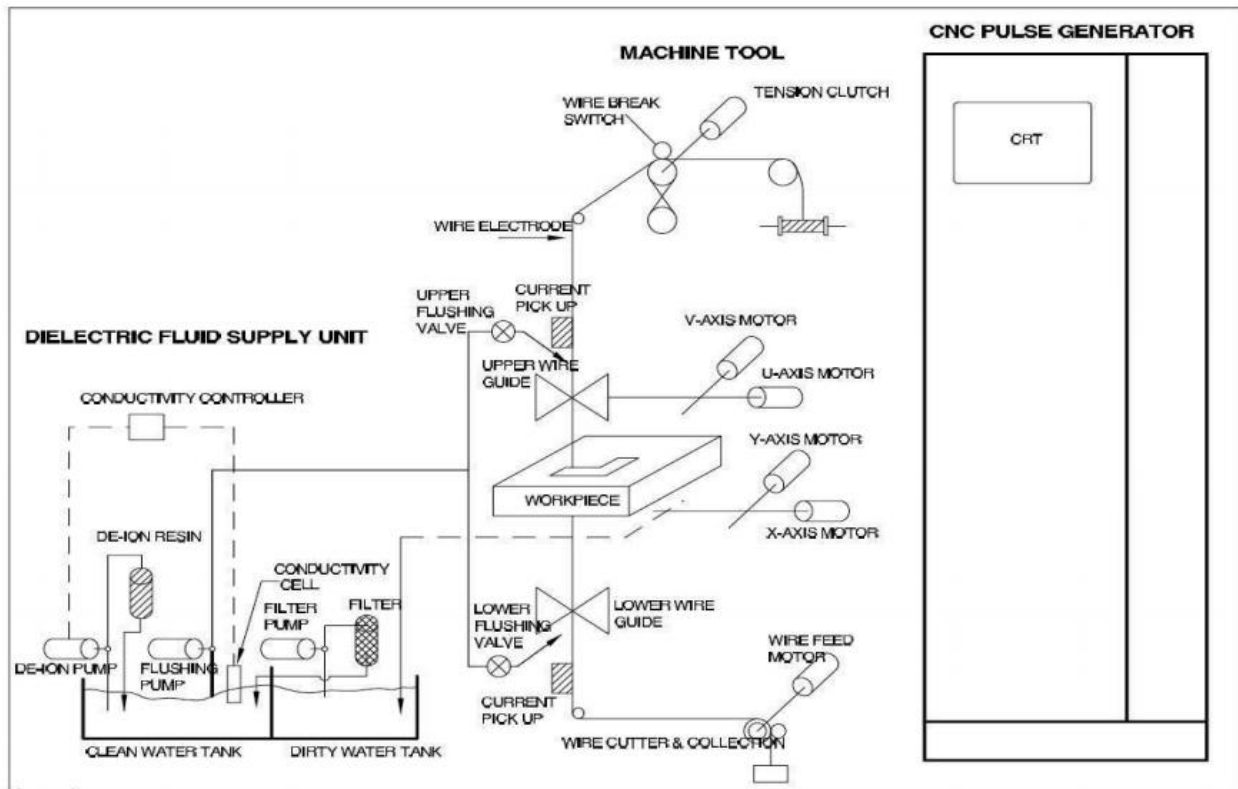

Figure 1.4: Pictorial View of WEDM Machine Tool

CHAPTER 2

BACKGROUND AND REVIEW OF LITERATURE

2.1 INTRODUCTION:

In this chapter search few selected research paper related to Wire-EDM with effect of surface roughness (SR), energy-distribution, Processing of Advanced Ceramics, Wear mechanism ,Machining of low electrical conductive materials, Parametric analysis, workpiece material

A background review of literature pertaining to this study includes a search of holdings in the DTU Library at Delhi. In addition to the literature search done at the library, information for this study was gathered from Internet searches, interviews with Asst. Professor Vipin Kumar and EDM expert Dean Brink of the EDM Technology Transfer Office Internet sources utilized for this research include EDM machine companies, EDMTT, and using various websites such as sciencedirect.com & springer.com etc.

Y.F. Luo[1] evaluates an energy-distribution strategy in fast-cutting wire EDM by taking Fundamental aspects of a stable fast-cutting process such as Polarity effect on the power distribution, Inefficient long discharge pulses, Significant Joule heat loss with high power density, De-ionization space and time and concluded that A very high cutting speed of 280mmZ/min was achieved by using molybdenum wire with a diameter of 0.14mm and a traveling rate of 16 m/s. The average output power of pulse generator was as high as 2.7 kHz, whilst the wire life still remained at 30000mm².

Ivano Belranfi , Axel Bertholds[2] presented study on a simplified post process for wire cut EDM, he presented a wire deflection analysis .It was shown that the wire deflection ha wire EDM can be described as a bending string, featuring a parabolic deflection. An original solution was discussed about the real time measurement mad correction of the wire position during wire EDM cutting. The description of an optical sensor was given as well as the strategy applied to remedy from comer imprecision.

Y.K. LOK and T. C. LEE[3] make study on processing of advanced ceramics using the wire-Cut EDM process using advanced ceramics such as Sialon and Al₂O₃-TiC It is feasible to process advanced engineering ceramics from the oxide and non-oxide group using the Wire-cut EDM

process, provided that the resistivity is less than the particular threshold value of 100 n-cm, However, the Volumetric Material Removal Rate (VMRR) for processing these ceramics materials were found to be very low as compared with cutting metals such as alloy steel SKD-II, and the surface roughness achieved with the Wire-cut EDM process is generally inferior to that with the die sinking EDM process.

Brian K. Rhoney, Albert J. Shih et al. [4] study on wear mechanism of metal bond diamond wheels trued by wire electrical discharge machining. The stereographic scanning electron microscopy (SEM) imaging was used to investigate the wear mechanism in wire electrical discharge machining (EDM) truing of metal bond diamond wheels for ceramic grinding. A piece of the grinding wheel was removed after truing and grinding to enable the examination of wheel surface and measurement of diamond protrusion heights using a SEM and stereographic imaging software. The stereographic SEM imaging method was calibrated by comparing with the profilometer measurement results. On the wheel surface after wire EDM truing and before grinding, some diamond grain protruding heights were measured in the $32\mu\text{m}$ level.

Y.S. Liao, J.T. Huang , Y.H. Chen[5] make a study to achieve a fine surface finish in Wire-EDM Many Wire-EDM machines have adopted the pulse-generating circuit using low power for ignition and high power for machining. However, it is not suitable for finishing process since the energy generated by the high-voltage sub-circuit is too high to obtain a desired fine surface, no matter how short the pulse-on time is assigned. For the machine used in this research, the best surface roughness Ra after finishing process is about $0.7\ \mu\text{m}$.

Mu-Tian Yan, Pin-Hsum Huang [6], Accuracy improvement of wire-EDM by real-time wire tension control In this paper, a closed-loop wire tension control system for a wire-EDM machine is presented to improve the machining accuracy. Dynamic models of the wire feed control apparatus and wire tension control apparatus are derived to analyze and design the control system. PI controller and one-step-ahead adaptive controller are employed to investigate the dynamic performance of the closed-loop wire tension control system. In order to reduce the vibration of wire tension during wire feeding, dynamic absorbers are added to the idle rollers of wire transportation mechanism. Experimental results not only demonstrate that the developed control system with dynamic absorbers can obtain fast transient response and small steady-state error than an open-loop control system, they also indicate that the geometrical contour error of

corner cutting is reduced with approximately 50% and the vertical straightness of a workpiece can be improved significantly.

Ahmet Haşçalýk, Ulas Çayda[7] present a experimental study of wire electrical discharge machining of AISI D5 tool steel. This paper presents an experimental investigation of the machining characteristics of AISI D5 tool steel in wire electrical discharge machining process. During experiments, parameters such as open circuit voltage, pulse duration, wire speed and dielectric fluid pressure were changed to explore their effect on the surface roughness and metallurgical structure. Optical and scanning electron microscopy, surface roughness and micro hardness tests were used to study the characteristics of the machined specimens. Taking into consideration the experimental results, it is found that the intensity of the process energy does affect the amount of recast and surface roughness as well as Microcracking, the wire speed and dielectric fluid pressure not seeming to have much of an influence.

K.H. Ho, S.T. Newman, etal. [8] states the art in wire electrical discharge machining (WEDM). Wire electrical discharge machining (WEDM) is a specialized thermal machining process capable of accurately machining parts with varying hardness or complex shapes, which have sharp edges that are very difficult to be machined by the main stream machining processes. This practical technology of the WEDM process is based on the conventional EDM sparking phenomenon utilizing the widely accepted non-contact technique of material removal. Since the introduction of the process, WEDM has evolved from a simple means of making tools and dies to the best alternative of producing micro-scale parts with the highest degree of dimensional accuracy and surface finish quality.

Over the years, the WEDM process has remained as a competitive and economical machining option fulfilling the demanding machining requirements imposed by the short product development cycles and the growing cost pressures. However, the risk of wire breakage and bending has undermined the full potential of the process drastically reducing the efficiency and accuracy of the WEDM operation. A significant amount of research has explored the different methodologies of achieving the ultimate WEDM goals of optimizing the numerous process parameters analytically with the total elimination of the wire breakages thereby also improving the overall machining reliability.

Jerzy Kozak , Kamlakar P. Rajurkar, Niraj Chandarana[9] make a study on machining of low electrical conductive materials by wire electrical discharge machining (WEDM). This theoretical and experimental study of WEDM of low conductive materials demonstrates that total electrical resistance between the workpiece and wire electrode vary during machining depending upon the clamping position. This change in resistance causes a change in material removal rate (MRR) and average surface roughness that leads to poor quality of products. A technique developed in this work minimizes the change in resistance offered by the workpiece material. A conductive silver coating is applied over the workpiece surface. Due to silver coating, the drop voltage in workpiece material is reduced; thereby decreasing energy loss in workpiece material. It was also observed that conductive silver coating not only minimizes the variation in resistance but also it increases the productivity of the process.

Hideo Takino, Toshimitsu Ichinohe, Katsunori Tanimoto, Syuichi Yamaguchi[10] give idea of cutting of polished single-crystal silicon by wire electrical discharge machining. In their paper, Smoothly polished single-crystal silicon plates were cut by wire electrical discharge machining (WEDM) in water and in oil in order to investigate the effect of WEDM on the polished surfaces. For cutting in water, polished surfaces near cut sections have chips and cracks, and are extremely rough; the rough regions are upheaved. Examinations suggest that the upheaved region is silicon dioxide and results from oxidization of the surfaces by WEDM. Moreover, the polished surfaces far from the cut section are somewhat rough. For cutting in oil, polished surfaces near a cut section are smooth and almost flat although they have chips and cracks. These findings indicate the WEDM in oil is better than that in water for cutting polished single-crystal silicon to obtain high-quality surfaces.

Hideo Takino, Toshimitsu Ichinohe, etal.[11] make a study on high-quality cutting of polished single-crystal silicon by wire electrical discharge machining. They discussed a method for cutting smoothly polished single-crystal silicon surfaces by wire electrical discharge machining to obtain a high-quality surface. To cut out parts with smooth surfaces from the plates by rough-cutting in water while maintaining the initial smoothness of the surfaces, several kinds of masks were applied to the polished surfaces before cutting. It was found that although the application of resin masks is effective for obtaining smooth surfaces far from the cut section, the surface smoothness near the section cut in water is less than in the case of cutting in oil. Next, finish-

cutting in oil was performed to remove cracks and chips generated by rough-cutting in oil. As a result, although a few chips were generated at edges of the cut section, cracks were successfully removed by finish-cutting, so that the surface quality was successfully improved by finish-cutting in oil.

S. Sarkar, S. Mitra, B. Bhattacharyya [12] make a parametric analysis and optimization of wire electrical discharge machining of γ -titanium aluminide alloy. In their paper, an investigation on wire electrical discharge machining of γ -titanium aluminide alloy. An extensive research study has been carried out with an aim to select the optimum cutting condition with an appropriate wire offset setting in order to get the desired surface finish and dimensional accuracy. The process has been modeled using additive model in order to predict the response parameters i.e. cutting speed, surface finish and dimensional deviation as function of different control parameters and the main influencing factors are determined for each given machining criteria. Finally, the optimum parametric setting for different machining situation arising out of customer requirements have been synthesized and reported in the paper.

- Experimental investigation on single pass cutting of wire electrical discharge machining of γ -TiAl alloy has been carried out. The process has been successfully modeled using additive model. The predicted response parameters from the model agreed quite well with that of the experimental result. Based on the developed model influence of the various process parameter on the machining criteria was observed. It was noted that both surface roughness as well as dimensional deviation is independent of the pulse off time. This aspect is very important as under certain critical machining condition pulse off time can be varied as per requirement to achieve better stability and accuracy without affecting the dimensional accuracy and surface finish significantly.

S. Sarkar, S. Mitra , B. Bhattacharyya[13] parametric optimization of wire electrical discharge machining of γ -titanium aluminide alloy through an artificial neural network model. In this research, wire electrical discharge machining (WEDM) of γ -titanium aluminide is studied. Selection of optimum machining parameter combinations for obtaining higher cutting efficiency and accuracy is a challenging task in WEDM due to the presence of a large number of process variables and complicated stochastic process mechanisms. In general, no perfect combination exists that can simultaneously result in both the best cutting speed and the best surface finish

quality. This paper presents an attempt to develop an appropriate machining strategy for a maximum process criteria yield. A feed forward back-propagation neural network is developed to model the machining process. The three most important parameters –cutting speed, surface roughness and wire offset have been considered as measures of the process performance. The model is capable of predicting the response parameters as a function of six different control parameters, i.e. pulse on time, and pulse off time, peak current, wire tension, dielectric flow rate and servo reference voltage. Experimental results demonstrate that the machining model is suitable and the optimization strategy satisfies practical requirements.

Bert Lauwers, Weidong Liu, and Wesley Eraerts [14] make study on influence of the Composition of WC-Based Cermets on Manufacturability by Wire-EDM. Tungsten carbide (WC) based cermets are widely used in applications where the demand for high-performance materials is essential. These materials are machined either by grinding or wire-EDM. In contrast to grinding, wire-EDM can be highly automated and allows the machining of complex shapes. A recent trend in the development of WC-based cermets is grain size refinement and more narrow grain size distributions of the starting powder material (WC, Co, Ni) which gives a higher hardness and abrasive wear resistance. This paper describes the influence of composition and grain size (coarse Micron) of WC-based cermets on manufacturability by wire-EDM. It is shown that the cutting rate decreases with increasing WC-grain size, which can be explained mainly by the change in thermal conductivity of the material. Further, the toughness of the base material has an important influence on the bending strength of the EDM-machined samples. Finally, the experiments show that for all investigated materials, the EDM material removal mechanism is mainly melting, while other mechanisms like spalling have not been recognized.

K. Kanlayasiri, S. Boonmung [15] present an investigation on effects of wire-EDM machining parameters on surface roughness of newly developed DC53 die steel, DC53 is a newly developed cold die steel from Daido Steel, Japan. It is an improvement over the familiar cold die steel SKD11. Because DC53 is a new die steel, only little information is available in literature for its machining characteristics. This paper investigated the effects of machining parameters on surface roughness of wire EDMed DC53 die steel. The investigated machining parameters were pulse-on time, pulse-off time, pulse-peak current, and wire tension. Analysis of variance

(ANOVA) technique was used to find out the parameters affecting the surface roughness. Assumptions of ANOVA were discussed and then examined through residual analysis. Quantitative testing methods on residual analysis were employed in place of the typical qualitative testing techniques. Results from ANOVA show that pulse-on time and pulse-peak current are significant variables to surface roughness of wire-EDMed DC53 die steel. The surface roughness of test specimen increased as these two variables increased.

K. Kanlayasiri, S. Boonmung[16], Effects of wire-EDM machining variables on surface roughness of newly developed DC 53 die steel: Design of experiments and regression model. DC53 is a newly developed cold die steel from Daido Steel, Japan. It is an improvement over the familiar cold die steel SKD11. Because DC53 is a new die steel, only little information is available in literature for its machining characteristics. This paper presents an investigation of the effects of machining variables on the surface roughness of wire-EDMed DC53 die steel. In this study, the machining variables investigated were pulse-peak current, pulse-on time, pulse-off time, and wire tension. Analysis of variance (ANOVA) technique was used to find out the variables affecting the surface roughness. Assumptions of ANOVA were discussed and carefully examined using analysis of residuals. Quantitative testing methods on residual analysis were used in place of the typical qualitative testing techniques. Results from the analysis show that pulse-on time and pulse-peak current are significant variables to the surface roughness of wire-EDMed DC53 die steel. The surface roughness of the test specimen increases when these two parameters increase. Lastly, a mathematical model was developed using multiple regression method to formulate the pulse-on time and pulse-peak current to the surface roughness. The developed model was validated with a new set of experimental data, and the maximum prediction error of the model was less than 7%.

Spiros Zinelis[17], Surface and elemental alterations of dental alloys induced by electro discharge machining (EDM). Objectives. To evaluate the surface and elemental alterations induced by electro discharge machining (EDM) on the surface of dental cast alloys used for the fabrication of implant retained meso- and super-structures.

- A completed cast model of an arch that received dental implants was used for the preparation of six wax patterns which were divided into three groups (Au, Co and Ti). The wax patterns of the Au and Co groups were invested with conventional phosphate-bonded silica-based investment material and the Ti group with magnesia-based investment material. The investment rings of the Au and Co groups were cast with an Au–Ag alloy (Stabilor G) and a Co–Cr base alloy (Okta C), respectively, while the investment rings of group Ti were cast with cp Ti (Biotan). One casting of each group was subjected to electro discharge machining (EDM); the other was conventionally ground and polished. The surface morphology and the elemental compositions of conventionally and EDM-finished surfaces were studied by SEM/X-ray EDS analysis. Six spectra were collected from each surface employing the area scan mode and the mean value of each element between conventionally and EDM-finished surfaces was statistically analyzed by t-test ($\alpha = 0.05$). Then the specimens of each group were cut perpendicular to their longitudinal axis and after metallographic grinding and polishing the cross-sections studied under the SEM.

Mu-Tian Yan, Yi-Peng Lai [18], Surface quality improvement of wire-EDM using a fine-finish power supply. This paper presents the development and application of a new fine-finish power supply in wire-EDM. The transistor-controlled power supply composed of a full-bridge circuit, two snubber circuits and a pulse control circuit was designed to provide the functions of anti-electrolysis, high frequency and very-low-energy pulse control. Test results indicated that the pulse duration of discharge current can be shortened through the adjustment of capacitance in parallel with the sparking gap. High value of capacitance contributes to longer discharge duration. A high current-limiting resistance results in the decrease of discharge current. Peak current increases with the increase of pulse on-time and thus contributes to an increase in thickness of recast layer. Experimental results not only verify the usefulness of the developed fine-finish power supply in eliminating titanium's bluing and rusting effect and reducing micro-cracking in tungsten carbide caused by electrolysis and oxidation, but also demonstrate that the developed system can achieve a fine surface finish as low as 0.22 mm Ra.

Mohammad Jafar Haddada, Alireza Fadaei Tehrani [19], Investigation of cylindrical wire electrical discharge turning (CWEDT) of AISI D3 tool steel based on statistical analysis In this

work, a surface roughness (Ra), roundness and material removal rate (MRR) study on the cylindrical wire electrical discharge turning (CWEDT) has been carried out. The material chosen in this case was AISI D3 tool steel due to its growing range of applications in the field of manufacturing tools dies and molds as punch, tapping, reaming and so on in cylindrical forms. This study was made only for the finishing stages and has been carried out on the influence of four design factors: power, voltage, and pulse off time and spindle rotational speed, over the three previous mentioned response variables. This has been done by means of the technique of design of experiments (DOE), which allows us to carry out the above-mentioned analysis performing a relatively small number of experiments. In this case, a $2^2 \times 3^2$ mixed full factorial design, has been selected considering the number of factors used in the present study. The resolution of this factorial design allows us to estimate all the main effects, factor interactions and pure quadratic effects of the four design factors selected to perform this study. For MRR, Ra and roundness regression models have been developed by using the response surface methodology (RSM).

I.Cabanesa, E. Portilloa , etal. [20] On-line prevention of wire breakage in wire electro-discharge machining. Wire electro-discharge machining (WEDM) is a fully extended and competitive machining process widely used to produce dies and moulds. However, the risk of wire breakage affects adversely the full potential of WEDM since the overall process efficiency is considerably reduced. The present paper discusses the results of the analyses of an exhaustive experimental database that reproduces unexpected disturbances that may appear during normal operation. The results of the analyses reveal new symptoms that allow one to predict wire breakage. These symptoms are especially related to the occurrence of an increase in discharge energy, peak current, as well as increases and/or decreases in ignition delay time. The differences observed in the symptoms related to workpiece thickness are also studied. Another contribution of this paper is the analyses of the distribution of the anticipation time for different validation tests. Based on the results of the analyses, this paper contributes to improve the process performance through a novel wire breakage monitoring and diagnosing system. It consists of two well differentiated parts: the virtual instrumentation system (VIS) that measures relevant magnitudes, and the diagnostic system (DS) that detects low quality cutting regimes and predicts wire breakage. It has been successfully validated through a considerable number of experimental tests performed on an industrial WEDM machine for different workpiece

thickness. The efficiency of the supervision system has been quantified through an efficiency rate defined in this paper.

Probir Saha & Abhijit Singha & Surjya K. Pal & Partha Saha[21], Soft computing models based prediction of cutting speed and surface roughness in wire electro-discharge machining of tungsten carbide cobalt composite. In the present study, a second order multi-variable regression model and a feed-forward back-propagation neural network (BPNN) model have been developed to correlate the input process parameters, such as pulse on-time, pulse off-time, peak current, and capacitance with the performance measures namely, cutting speed and surface roughness while wire electro-discharge machining (WEDM) of tungsten carbide-cobalt (WC-Co) composite material. From a large number of neural network architectures, 4-11-2 has been found to be the optimal one, which can predict cutting speed and surface roughness with 3.29% overall mean prediction error. The multivariable regression model yields an overall mean prediction error of 6.02%. Both the models have been used to study the effect of input parameters on the cutting speed and surface roughness, and finally to corroborate them with those of the experimental results. Scanning electron micrographs reveal that at higher energy level the machined surface is characterized by several micro cracks and loosely bound solidified WC grains.

Thomas R. Newton, et al. [22] Investigation of the effect of process parameters on the formation and characteristics of recast layer in wire-EDM of Inconel 718. Inconel 718 is a high nickel content superalloy possessing high strength at elevated temperatures and resistance to oxidation and corrosion. The non-traditional manufacturing process of wire-electrical discharge machining (EDM) possesses many advantages over traditional machining during the manufacture of Inconel 718 parts. However, certain detrimental effects are also present and are due in large part to the formation of the recast layer. An experimental investigation was conducted to determine the main EDM parameters which contribute to recast layer formation in Inconel 718. It was found that average recast layer thickness increased primarily with energy per spark, peak discharge current, and current pulse duration. Over the range of parameters tested, the recast layer was observed to be between 5 and 9µm average thickness, although highly variable in nature. The recast material was found to possess in-plane tensile residual stresses, as well as lower hardness and elastic modulus than the bulk material.

Mu-Tian Yan, Yi-Ting Liu [23], Design, analysis and experimental study of a high-frequency power supply for finish cut of wire-EDM. This paper presents the development of a high-frequency power supply for surface quality improvement of wire electrical discharge machining (wire-EDM). A novel fixed pulse-width modulation pulse control method is proposed to generate high-frequency and short-duration pulse control signals. A spark gap model using a resistance–capacitance (RC) circuit and a Zener diode is proposed for circuit design and simulation analysis. Tests revealed that the developed power supply using anti-electrolysis circuitry and digital signal processor-based pulse control circuit can provide very low discharge energy pulses with a frequency of 4.4MHz, discharge duration of 90 ns and a peak current of 1.2 A. Experimental results demonstrate that a pulse duration ratio (defined as a ratio between pulse duration of positive polarity and that of negative polarity) of three can reduce the electrolytic effect of tungsten carbide for the machining conditions of high discharge frequency more than 500 kHz.

Dinesh Rakwal, Eberhard Bamberg[24], Slicing, cleaning and kerf analysis of germanium wafers machined by wire electrical discharge machining. This paper investigates the slicing of germanium wafers from single crystal, gallium-doped ingots using wire electrical discharge machining. Wafers with a thickness of 350 μ m and a diameter of 66mm were cut using 75 and 100 μ m molybdenum wire. Wafer characteristics resulting from the process such as the surface profile and texture are analyzed using a surface profiler and scanning electron microscopy. Detailed experimental investigation of the kerf measurement was performed to demonstrate minimization of material wastage during the slicing process using WEDM in combination with thin wire diameters. A series of timed etches using two different chemical etchants were performed on the machined surfaces to measure the thickness of the recast layer. Cleaning of germanium wafers along with its quality after slicing is demonstrated by using Raman spectroscopy.

2.2 OBJECTIVE OF THE PRESENT WORK:

From the research papers in this classification, it is observed that few works has been reported on wire EDM on the material Al-SiC, EN-19, SKH 57, AISI H13, AISI D3 tool steel, and various composite materials. Study on wire EDM of different material and different mathematical model can be used to validated the experimental results.

The objective of the present work is an attempt to finding the effect of parameter on machining of AISI D3 die steel through wire cut EDM. The machining parameters selected are wire feed rate, pulse on time and gap voltage and do regression analysis to optimize process parameter for best surface finish (SF).

CHAPTER – 3

EXPERIMENTAL SET-UP AND PROCESS PARAMETER SELECTION

3.1 MACHINE TOOL

The experiments were carried out on a wire-cut EDM machine (Ezeecut plus Wire EDM) of Electronica Machine Tools Ltd. installed at Advanced Manufacturing Laboratory of Mechanical Engineering Department of Delhi Technology University ,Delhi

The WEDM machine tool (Figure 1.1) has the following specifications:

Machine Tool	Ezeecut plus
Design	: Fixed column, moving table
Max. workpiece size	: 360 x 600 mm
Max. Z height	: 400 mm
Max. workpiece weight	: 300 kg
Main table traverse (X, Y)	: 320, 400 mm
Auxiliary table traverse (u, v)	: 25, 25 mm
Max. Taper cutting angle	: $0 \pm 3 / 100$ mm
Wire diameter	: 0.2 to 0.25 mm (Brass) : 0.12 to 0.25 mm (Molybdenum)
Display	: 15" VGA colour CRT
Min. input command	: 0.001 mm
Min. increment	: 0.001 mm

Interpolation function : Linear & Circular

Simultaneously controlled axes : X, Y, u, v

Min. resolution for X,Y,u, v : 0.001 mm

Data Input / Output : 1.44 MB floppy disc

Input power supply : 3 phase, 415 V AC, 50 Hz

Connected load : 1.5 kVA

Dielectric fluid : Tap water + Coolant oil (20:1)

Tank capacity : 40 Litres

Machine Floor Plan

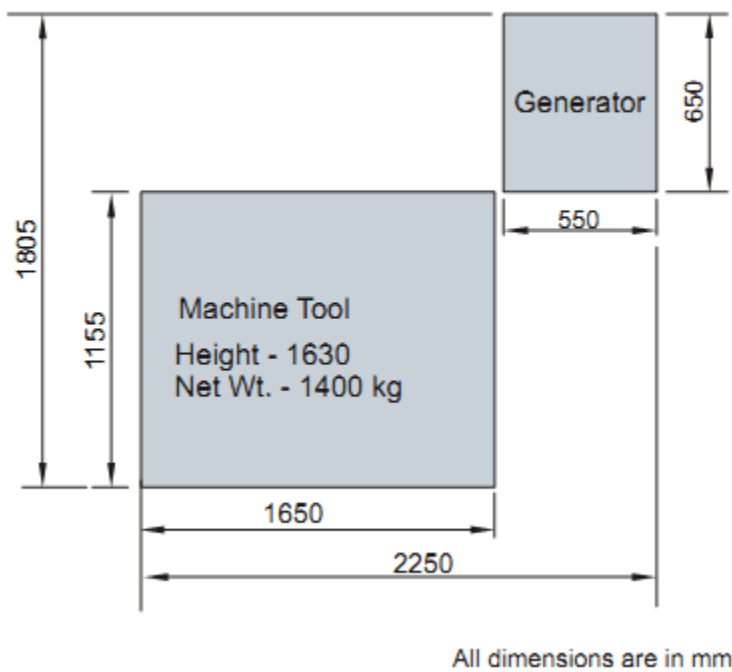

Figure 3.1: Machine Floor Plan

3.2. WORK PIECE MATERIAL

AISI D3 - High Carbon and High Chrome Tool Steel .D3 is a high carbon-high chromium steel developed for applications requiring high resistance to wear or to abrasion and for resistance to heavy pressure rather than to sudden shock. Because of these qualities and its non-deforming properties, D3 is unsurpassed for die work on long production runs. It is primarily oil-hardening steel, and it hardens to a great depth. The production from a die after each grind is consistently uniform. While the impact strength is comparatively low, by proper adjustment of tool design and heat treatment, this steel has been used successfully for punches and dies on quite heavy material.

APPLICATION of D3 is the following:

1. Blanking, stamping, and cold forming dies and punches for long runs; lamination dies
2. Bending, forming, and seaming rolls
3. Cold trimmer dies or rolls
4. Burnishing dies or rolls
5. Plug gages
6. Drawing dies for bars or wire
7. Slitting cutters
8. Lathe centers subject to severe wear

Description of workpiece material is as follows ...

workpiece material - AISI D3

Chemical Composition: The chemical composition of this material as Obtained by EDAX (Electro Dispersive X-ray Spectroscopy) test is given in Table 3.1

Table 3.1: Chemical Composition of the Material

Element	C	Mn	Si	Cr	Ni	W	V	Cu	P	S	Fe
Weight %	2.00-2.35	0.60	0.60	11.00-13.50	0.30	1.00	1.00	0.25	0.03	0.03	Rest

Mechanical Properties:-Properties at 25⁰C

Density ($\times 1000 \text{ kg/m}^3$)	- 7.7
Poisson's Ratio	- 0.27-0.30
Elastic Modulus (GPa)	- 190-210
Surface hardness	- 60 HRC

Workpiece size (L \times W \times T) -200 \times 50 \times 12 (in mm)

Description of electrode material is as fallows....

Electrode type	- wire electrode
Electrode material	- copper (35 wt%Zn)
Wire diameter	- 0.25 mm
Tension	- upto 15 kgf/mm ²

The wire-EDM machine used in this study was EZEECUT PLUS CNC WIRECUT EDM

After machining, the specimen was measured surface roughness of the EDMed surface along the cutting direction. The surface finish parameter employed to indicate the surface quality in this experiment was the arithmetic mean roughness (Ra).and it can be measured by Taylor and Hobson instrument (shown in figure 3.2). The Scan length and cut-off length of the measurement were 10 and 25 mm, respectively.



Figure 3.2: Taylor Hobson instrument

3.3 PREPARATION OF SPECIMENS

The AISI D3 die steel plate of 200mm×50mm×12mm size is mounted on the EZEECUT PLUS WIRECUT EDM machine tool (Figure 1.1) and specimens of 12mm×5mm×25mm size are cut. The close up view of plate blank used for cutting the specimens is shown mounted on the WEDM machine (Figure 3.3). A set of cut specimens is shown in Figures 3.4 and 3.5.



Figure 3.3: Specimens is shown mounted on the WEDM machine

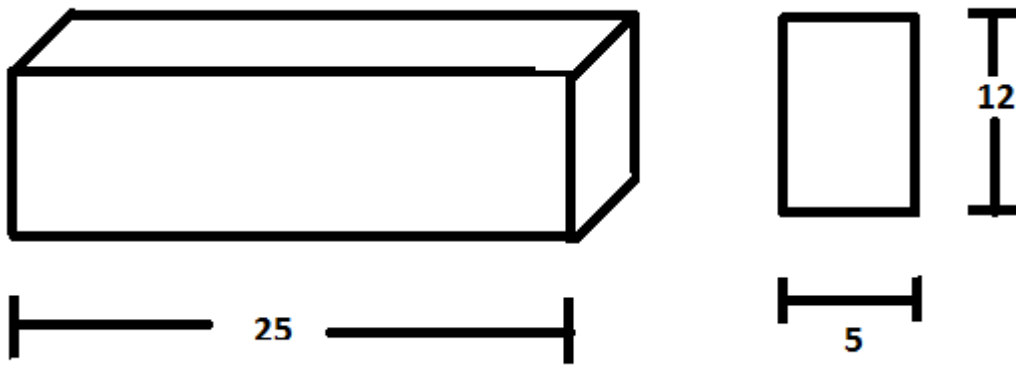

Figures 3.4: Cutting Specimen dimension in mm



Figures 3.5: View of cutting specimen

3.4 EXPERIMENTATION

The experiments were accomplished on an Ezeecut plus Wire EDM machine.

Following steps were followed in the cutting operation:

1. The wire was made vertical with the help of verticality block.
2. The work piece was mounted and clamped on the work table.
3. A reference point on the workpiece was set for setting work co-ordinate system (WCS). The programming was done with the reference to the WCS. The reference point was defined by the ground edges of the work piece.
4. The program was made for cutting operation of the work piece and a profile of 12mmx5mmx25mm was cut.

While performing various experiments, the following precautionary measures were taken:

1. To reduce error due to experimental set up, each experiment was repeated three times in each of the trial conditions.
2. The order and replication of experiment was randomized to avoid bias, if any, in the results.
3. Each set of experiments was performed at room temperature in a narrow temperature range ($32\pm 2^{\circ}$ C).
4. Before taking measurements of surface roughness, the workpiece was cleaned with acetone.
Taylor Hobson instrument is used in this study to measure Ra value.

3.5 SELECTION OF PROCESS PARAMETERS

3.5.1 Pulse on Time

The pulse on time is referred as T_{on} and it represents the duration of time in micro seconds, μs , for which the current is flowing in each cycle (Figure 3.9). During this time the voltage, VP, is applied across the electrodes. The T_{on} setting time range available on the machine tool is 1-99

which is applied in steps of 1 unit. The single pulse discharge energy increases with increasing Ton period, resulting in higher cutting rate. With higher values of Ton, however, surface roughness tends to be higher. The higher value of discharge energy may also cause wire breakage

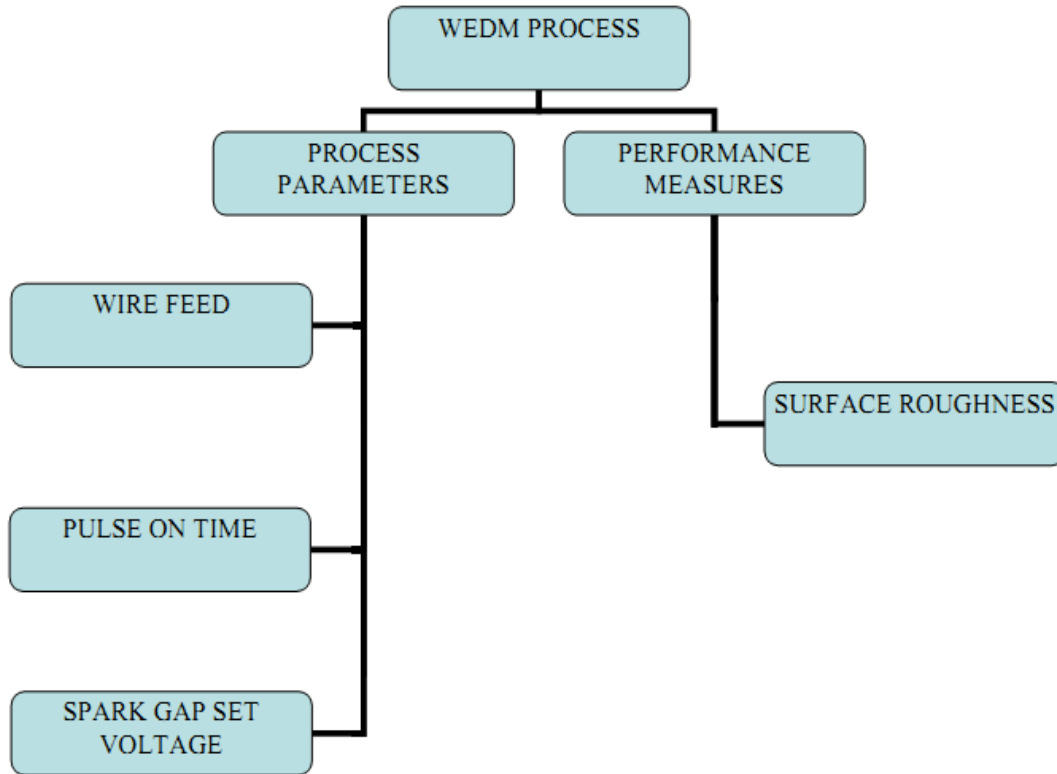

Figures 3.6: Process Parameters and Performance Measures of WEDM

3.5.2 Pulse off Time

The pulse off time is referred as Toff and it represents the duration of time in micro seconds, μs , between the two simultaneous sparks (Figure 3.7). The voltage is absent during this part of the cycle. The Toff setting time range available on the machine tool is 00 - 15 which is applied in steps of 1 unit. With a lower value of Toff, there is more number of discharges in a given time, resulting in increase in the sparking efficiency. As a result, the cutting rate also increases. Using very low values of Toff period, however, may cause wire breakage which in turn reduces the cutting efficiency. As and when the discharge

conditions become unstable, one can increase the Toff period. This will allow lower pulse duty factor and will reduce the average gap current. It kept fixed 15 μ s for all experiment.

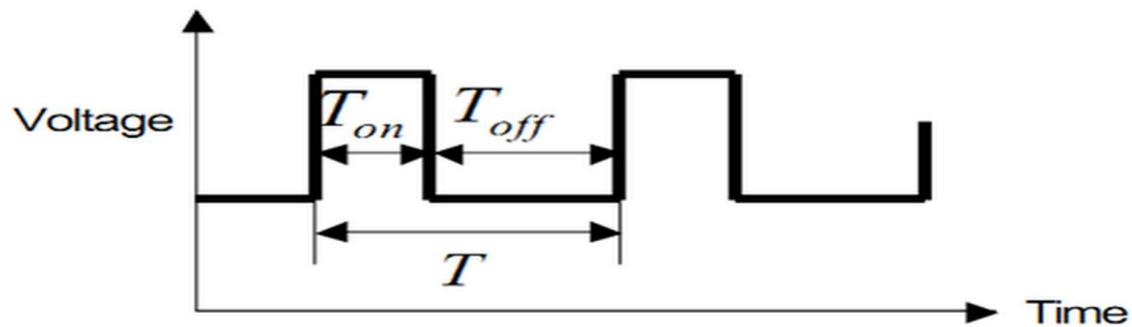

Figures 3.7: Series of Electrical Pulses at the Inter Electrode Gap

3.5.3 Peak Current

The peak current is represented by I_p and it is the maximum value of the current passing through the electrodes for the given pulse. The I_p setting current range available on the present WEDM machine is 0-4 unit which is applied in steps of 1 unit. Increase in the I_p value will increase the pulse discharge energy which in turn can improve the cutting rate further. For higher value of I_p , gap conditions may become unstable with improper combination of T_{on} , T_{off} , V_g & SF settings. As and when the discharge conditions become unstable one must reduce the I_p value. It kept fixed 4 for all experiment.

3.5.4 Spark Gap Set Voltage

The spark gap set voltage is a reference voltage for the actual gap between the workpiece and the wire used for cutting. The SV voltage range available on the present machine is 00 - 99 volt and is applied in steps of 1 volt.

3.5.5 Wire Feed

Wire feed is the rate at which the wire-electrode travels along the wire guide path and is fed continuously for sparking. The wire feed range available on the present WEDM machine is 0-100 unit in steps of 1 unit. It is always desirable to set the wire feed to maximum. This will result in less wire breakage, better machining stability and slightly more cutting speed.

CHAPTER 4

DESIGN OF EXPERIMENT:

In general usage, design of experiments (DOE) or experimental design is the design of any information-gathering exercises where variation is present, whether under the full control of the experimenter or not. However, in statistics, these terms are usually used for controlled experiments. Other types of study, and their design, are discussed in the articles on opinion polls and statistical surveys (which are types of observational study), natural experiments and quasi-experiments (for example, quasi-experimental design). See Experiment for the distinction between these types of experiments or studies.

In the design of experiments, the experimenter is often interested in the effect of some process or intervention (the "treatment") on some objects (the "experimental units"), which may be people, parts of people, groups of people, plants, animals, materials, etc. Design of experiments is thus a discipline that has very broad application across all the natural and social sciences.

4.1 INTRODUCTION TO FACTORIAL EXPERIMENT:

In statistics, a full factorial experiment is an experiment whose design consists of two or more factors, each with discrete possible values or "levels", and whose experimental units take on all possible combinations of these levels across all such factors. A full factorial design may also be called a fully crossed design. Such an experiment allows studying the effect of each factor on the response variable, as well as the effects of interactions between factors on the response variable.

For the vast majority of factorial experiments, each factor has only two levels. With two factors each taking two levels, a factorial experiment would have four treatment combinations in total, and is usually called a 2×2 factorial design.

If the number of combinations in a full factorial design is too high to be logistically feasible, a fractional factorial design may be done, in which some of the possible combinations (usually at least half) are omitted.

4.1 HISTORY OF METHODOLOGY:

Factorial designs were used in the 19th century by John Bennet Lawes and Joseph Henry Gilbert of the Station. Ronald argued in 1926 that "complex" designs (such as factorial designs) were more efficient than studying one factor at a time.

Fisher wrote,

"No aphorism is more frequently repeated in connection with field trials, than that we must ask Nature few questions, or, ideally, one question, at a time. The writer is convinced that this view is wholly mistaken."

Nature, he suggests, will best respond to a logical and carefully thought out questionnaire". A factorial design allows the effect of several factors and even interactions between them to be determined with the same number of trials as are necessary to determine any one of the effects by itself with the same degree of accuracy.

Frank Yates made significant contributions, particularly in the analysis of designs, by the Yates analysis.

The term "factorial" may not have been used in print before 1935, when Fisher used it in his book *The Design of Experiments*.

4.2 EXAMPLE:

The simplest factorial experiment contains two levels for each of two factors. Suppose an engineer wishes to study the total power used by each of two different motors, A and B, running at each of two different speeds, 2000 or 3000 RPM. The factorial experiment would consist of four experimental units: motor A at 2000 RPM, motor B at 2000 RPM, motor A at 3000 RPM, and motor B at 3000 RPM. Each combination of a single level selected from every factor is present once.

This experiment is an example of a 2^2 (or 2×2) factorial experiment, so named because it considers two levels (the base) for each of two factors (the power or superscript), or $\text{\#levels}^{\text{\#factors}}$, producing $2^2=4$ factorial points.

Designs can involve many independent variables. As a further example, the effects of three input variables can be evaluated in eight experimental conditions shown as the corners of a cube.

This can be conducted with or without replication, depending on its intended purpose and available resources. It will provide the effects of the three independent variables on the dependent variable and possible interactions.

4.3 IMPLEMENTATION:

For more than two factors, a 2^k factorial experiment can be usually recursively designed from a 2^{k-1} factorial experiment by replicating the 2^{k-1} experiment, assigning the first replicate to the first (or low) level of the new factor, and the second replicate to the second (or high) level. This framework can be generalized to, *e.g.*, designing three replicates for three level factors, *etc.*

A factorial experiment allows for estimation of experimental error in two ways. The experiment can be replicated, or the sparsity-of-effects principle can often be exploited. Replication is more common for small experiments and is a very reliable way of assessing experimental error. When the number of factors is large (typically more than about 5 factors, but this does vary by application), replication of the design can become operationally difficult. In these cases, it is common to only run a single replicate of the design, and to assume that factor interactions of more than a certain order (say, between three or more factors) are negligible. Under this assumption, estimates of such high order interactions are estimates of an exact zero, thus really an estimate of experimental error.

When there are many factors, many experimental runs will be necessary, even without replication. For example, experimenting with 10 factors at two levels each produces $2^{10}=1024$ combinations. At some point this becomes infeasible due to high cost or insufficient resources. In this case, fractional factorial designs may be used.

As with any statistical experiment, the experimental runs in a factorial experiment should be randomized to reduce the impact that bias could have on the experimental results. In practice, this can be a large operational challenge.

Factorial experiments can be used when there are more than two levels of each factor. However, the number of experimental runs required for three-level (or more) factorial designs will be considerably greater than for their two-level counterparts.

4.4 ANALYSIS:

A factorial experiment can be analyzed using ANOVA or regression analysis. It is relatively easy to estimate the main effect for a factor. To compute the main effect of a factor "A", subtract the average response of all experimental runs for which A was at its low (or first) level from the average response of all experimental runs for which A was at its high (or second) level.

The experiment performed in this study was a screening experiment. The experimental strategy used in this experiment was full factorial design.

If we select all possible experiment, total no. of experiment = m^n

Where m = no. of reading for each variable or no. of levels

n = no. of variable or no. of factor

Here we take three variable i.e. wire feed rate, pulse on time, and gap voltage. And take three reading for each variable, hence

$m = 3$ & $n = 3$

Total no. of experiment = $3^3 = 27$

As per above discussion this experiment has **3 factor at 3 level each produces $3^3=27$** combinations.

Table 4.1 for variable and respective reading is given below.

Variable		Reading for each variable		
		Level 1	Level 2	Level 3
Factor 1	Wire feed rate(F) in m/min	25	50	75
Factor 2	Pulse ON time(Ton) in μ s	25	50	75
Factor 3	Gap voltage(Vg) in volt	25	50	75

CHAPTER 5 DATA COLLECTION

5.1 INTRODUCTION:

As per above discussion, here we have three parameter whose variation is checked on surface roughness of machined surface .variable and their respective no. of reading shown in table 5.1.

Table 5.1: Variable and respective no. of reading

Variable	Reading for each variable		
Wire feed rate(F) in m/min	25	50	75
Pulse ON time(Ton) in μ s	25	50	75
Gap voltage(Vg) in volt	25	50	75

Experiment Table:

As per above mentioned variable and readings there are following no. of combination are shown in table 5.2

Table 5.2: Set of experiment with their Ra value.

Experiment no.	Wire feed rate(F) in m/min	Pulse ON time(Ton) in μ s	Gap voltage(Vg) in volt	Ra(μ m)
1.	25	25	25	7.22
2.	25	25	50	4.5
3.	25	25	75	4.22
4.	25	50	25	8.6
5.	25	50	50	5.22
6.	25	50	75	4.51
7.	25	75	25	9.2
8.	25	75	50	5.76
9.	25	75	75	4.63

10.	50	25	25	5.73
11.	50	25	50	4.06
12.	50	25	75	3.42
13.	50	50	25	5.84
14.	50	50	50	3.6
15.	50	50	75	3.26
16.	50	75	25	5.94
17.	50	75	50	3.92
18.	50	75	75	3.8
19.	75	25	25	5.46
20.	75	25	50	4.26
21.	75	25	75	4.92
22.	75	50	25	5.8
23.	75	50	50	3.76
24.	75	50	75	3.6
25.	75	75	25	5.99
26.	75	75	50	3.26
27.	75	75	75	3.1

EXPERIMENTAL DESIGN METHODOLOGY:

A scientific approach to plan the experiments is a necessity for efficient conduct of experiments. By the statistical design of experiments the process of planning the experiment is carried out, so that appropriate data will be collected and analyzed by statistical methods resulting in valid and objective conclusions. Here we take all possible experiment as per in table 5.2 and made an equation of second order in respect of surface roughness by use of software named **Engineering Equation Solver (EES)**.

For forming equation through EES, first we have to decide dependent and independent variables which are given as follows

Dependent variable: Surface roughness (Ra)

Independent variable: 1. Wire feed rate (F)

2. Pulse on time (Ton)

3. Spark gap Voltage (Vg)

Polynomial order = 2

Equation formed by EES...

$$\text{Column4} = 1.53496296\text{E}+01 - 1.62644444\text{E}-01 * \text{Column1} + 1.32177777\text{E}-03 * \text{Column1}^2 - 4.95555556\text{E}-03 * \text{Column2} + 8.97777778\text{E}-05 * \text{Column2}^2 - 2.19022222\text{E}-01 * \text{Column3} + 1.64977778\text{E}-03 * \text{Column3}^2 \quad \dots\dots\dots \text{(Equation 5.1)}$$

Where,

Column4= Surface Roughness (Ra)

Column1= Wire feed rate (WFR)

Column2= Pulse on time (Ton)

Column3= Spark gap Voltage (Vg).

Hence, formed equation (5.1) also written as

$$\text{Ra} = 1.53496296\text{E}+01 - 1.62644444\text{E}-01 * \text{WFR} + 1.32177777\text{E}-03 * \text{WFR}^2 - 4.95555556\text{E}-03 * \text{Ton} + 8.97777778\text{E}-05 * \text{Ton}^2 - 2.19022222\text{E}-01 * \text{Vg} + 1.64977778\text{E}-03 * \text{Vg}^2 \quad \dots\dots\dots \text{(Equation 5.2)}$$

On the basis of equation (5.2) analysis is made to check the effect of selected variable on surface roughness which is discussed in next chapter.

CHAPTER 6

RESULT AND DISCUSSION

6.1 INTRODUCTION:

This chapter is related about the effect of selected variable i.e. Wire feed rate, pulse on time and spark gap voltage on surface roughness of workpiece with help of nonlinear equation (equation 5.2) as mentioned above.

6.2 EFFECT OF WIRE FEED RATE ON SURFACE ROUGHNESS:

The wire feed is varied from 10 unit to 90 unit in the steps of 10unit values of the other parameters are kept constant and their values are given as $T_{off} = 15 \mu s$; $IP = 4$ unit; group pulse = 5unit ; $SEN = 10$. At different value of WFR, the value of arithmetic mean roughness (R_a) can be finding by following equation by keeping other value (like T_{on} and V_g) constant.

So there is three graph between R_a and WFR at three different value of V_g (i.e. 25,50 & 75) and every graph has three curve at three different value of T_{on} (i.e.25,75 & 125).

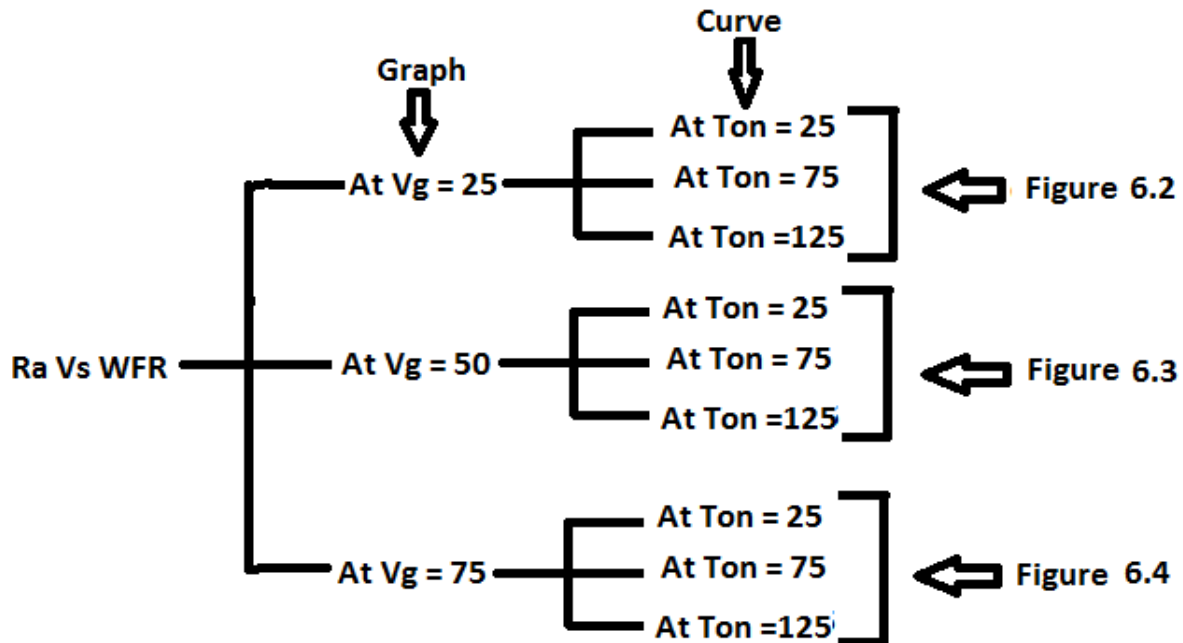

Figure 6.1 Reading tree for 3 graphs with each have 3 curves.

As per above discussion we find value of wire feed rate at which best surface finish can be achieved. The experimentally observed data for the performance measures for different values of wire feed is given in Table 6.1

Table 6.1: Performance Measures for Wire Feed Rate at $V_g=25$ volt

WFR(m/min)	Ton=25 (μ s)	Vg(V)=25	Ra(μ m)	Ton=75 μ s	Ra(μ m)	Ton=100 μ s	Ra(μ m)
10	25	25	9.343141	75	9.544252	125	10.19425
20	25	25	8.11323	75	8.314341	125	8.964341
30	25	25	7.147674	75	7.348785	125	7.998785
40	25	25	6.446474	75	6.647585	125	7.297585
50	25	25	6.00963	75	6.210741	125	6.860741
60	25	25	5.837141	75	6.038252	125	6.688252
70	25	25	5.929007	75	6.130118	125	6.780118
80	25	25	6.28523	75	6.486341	125	7.136341
90	25	25	6.905807	75	7.106918	125	7.756918

***Bold** value gives lowest surface roughness.

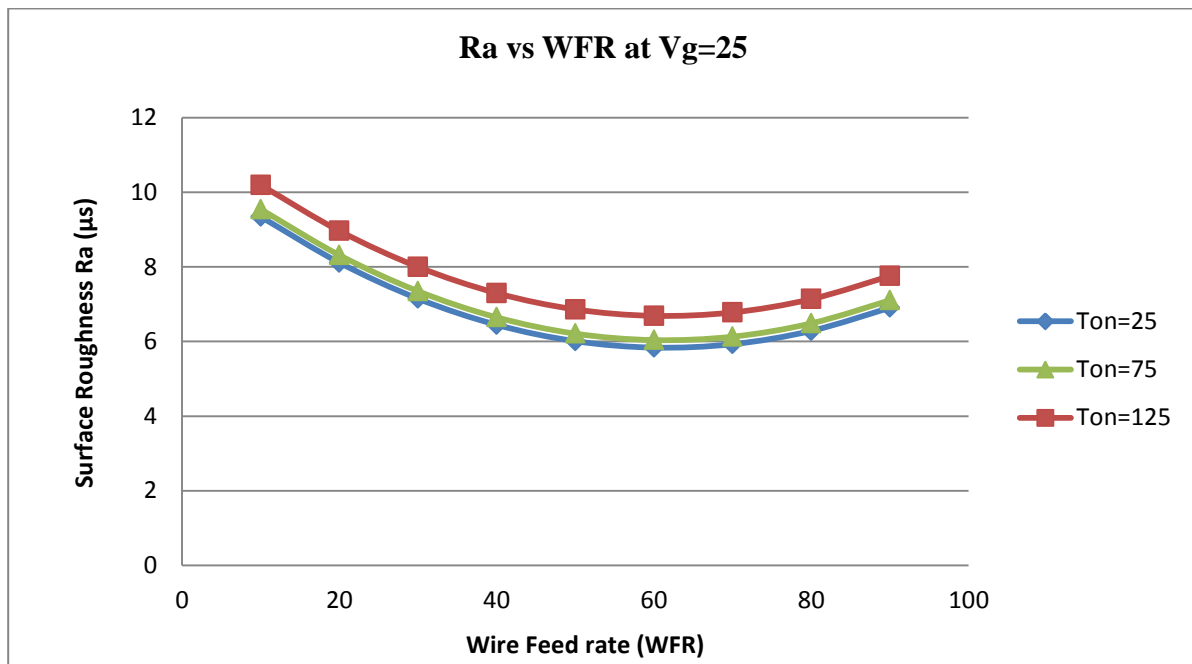

Figure 6.2: Effect of wire feed rate on surface roughness.

Table 6.2: Performance Measures for Wire Feed at $V_g=50$ volt

WFR(m/min)	Ton(μ s)=25	Vg(V)=50	Ra(μ m)	Ton(μ s)=75	Ra(μ m)	Ton(μ s)=125	Ra(μ m)
10	25	50	7.046548	75	6.702104	125	6.50877
20	25	50	5.820637	75	5.476193	125	5.282859
30	25	50	4.862637	75	4.518193	125	4.324859
40	25	50	4.172548	75	3.828104	125	3.63477
50	25	50	3.75037	75	3.405926	125	3.212593
60	25	50	3.596104	75	3.251659	125	3.058326
70	25	50	3.709748	75	3.365304	125	3.17197
80	25	50	4.091304	75	3.746859	125	3.553526
90	25	50	4.74077	75	4.396326	125	4.202992

***Bold** value gives lowest surface roughness

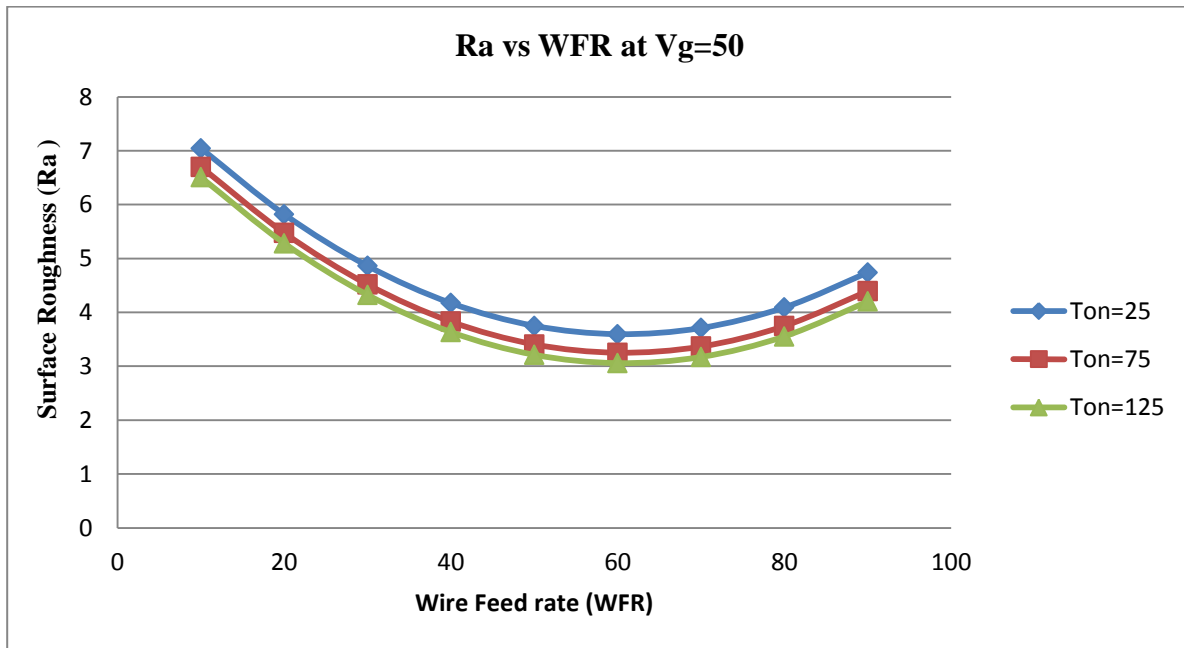

Figure 6.3: Effect of wire feed rate on surface roughness.

Table 6.3: Performance Measures for Wire Feed at $V_g=75$ volt

WFR(m/min)	Ton(μ s)=25	Vg(V)=75	Ra(μ m)	Ton(μ s)=75	Ra(μ m)	Ton(μ s)=125	Ra(μ m)
10	25	75	6.874326	75	6.529881	125	6.336548
20	25	75	5.648415	75	5.30397	125	5.110637
30	25	75	4.690415	75	4.34597	125	4.152637
40	25	75	4.000326	75	3.655881	125	3.462548
50	25	75	3.578148	75	3.233704	125	3.04037
60	25	75	3.423881	75	3.079437	125	2.886104
70	25	75	3.537526	75	3.193081	125	2.999748
80	25	75	3.919081	75	3.574637	125	3.381304
90	25	75	4.568548	75	4.224104	125	4.03077

***Bold** value gives lowest surface roughness

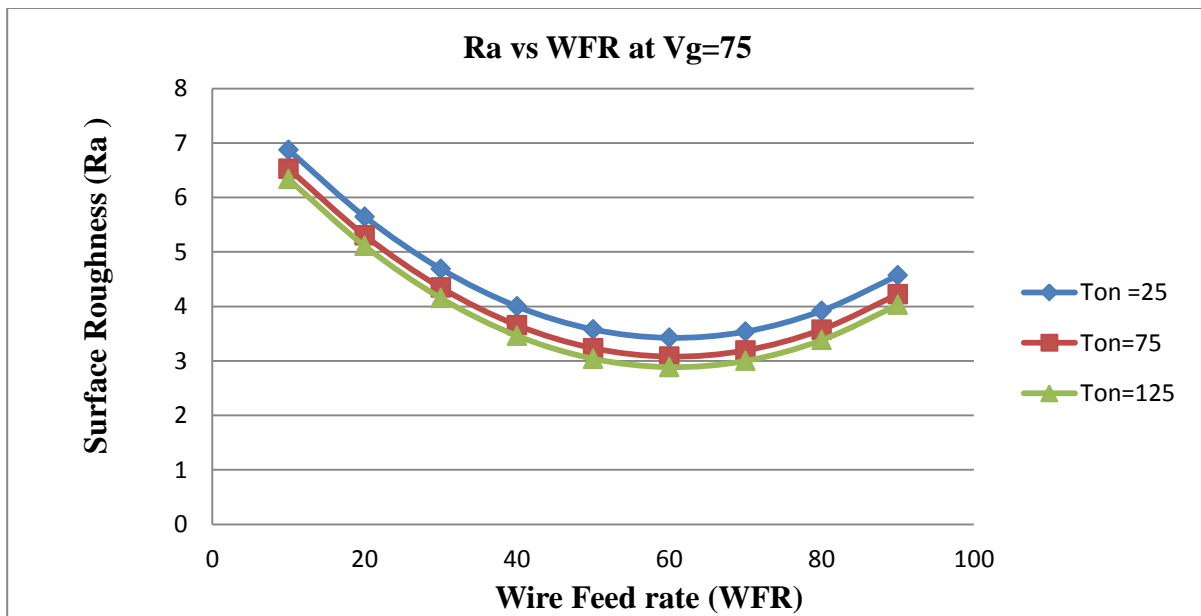

Figure 6.4: Effect of wire feed rate on surface roughness.

Figure 6.2, Figure 6.3 and Figure 6.4 shows the scatter plots of wire feed versus surface roughness characteristics. The pulse on time and gap voltage remains constant with the increase in wire feed, surface roughness first decreases then increases.

Best surface Finish can be obtained at wire feed rate of 60 units (approx.)

6.3 EFFECT OF PULSE ON TIME ON SURFACE ROUGHNESS:

The pulse on time (T_{on}) is varied from 10 units to 100 units in steps of 10 units. Since from above observation best surface finish can be obtained at $WFR=60$ hence this WFR is fixed in further analysis. The values of the other parameters are kept constant and their values are given as $T_{off} = 15$ unit; $I_p = 4$ unit; group pulse = 5unit; $SEN = 10$.

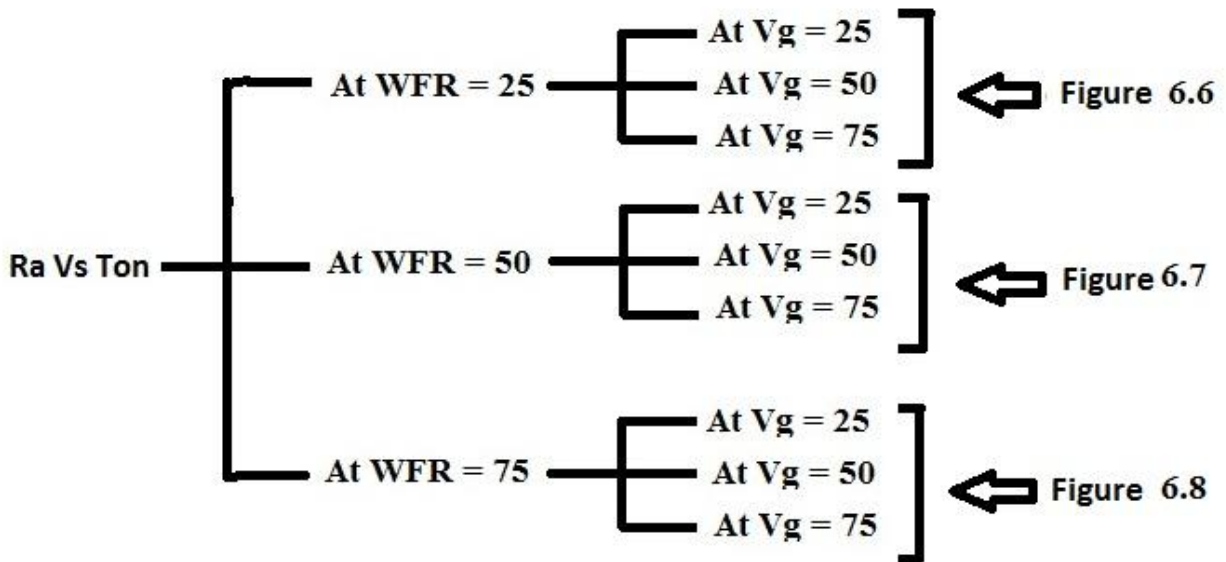

Figure 6.5: Reading tree for 1 graph with each have 3 curves

The experimentally observed data for the surface roughness for different values of pulse on time is given in Table 6.4. Figure 6.6 shows the scatter plots of pulse on time versus response characteristics.

The value of surface roughness though increases with increase in pulse on time is shown in following figures.

Table 6.4: Performance Measures for Pulse on Time at WFR=25 units

Ton(μ s)	WFR(m/min)	Vg (V)	Ra(μ m)	Vg (V)	Ra(μ m)	Vg (V)	Ra(μ m)
10	25	25	7.624607	50	5.242385	75	4.922385
20	25	25	7.601985	50	5.219763	75	4.899763
30	25	25	7.597319	50	5.215096	75	4.895096
40	25	25	7.610607	50	5.228385	75	4.908385
50	25	25	7.641852	50	5.25963	75	4.93963
60	25	25	7.691052	50	5.30883	75	4.98883
70	25	25	7.758207	50	5.375985	75	5.055985
80	25	25	7.843319	50	5.461096	75	5.141096
90	25	25	7.946385	50	5.564163	75	5.244163
100	25	25	8.067407	50	5.685185	75	5.365185

***Bold** value gives lowest surface roughness

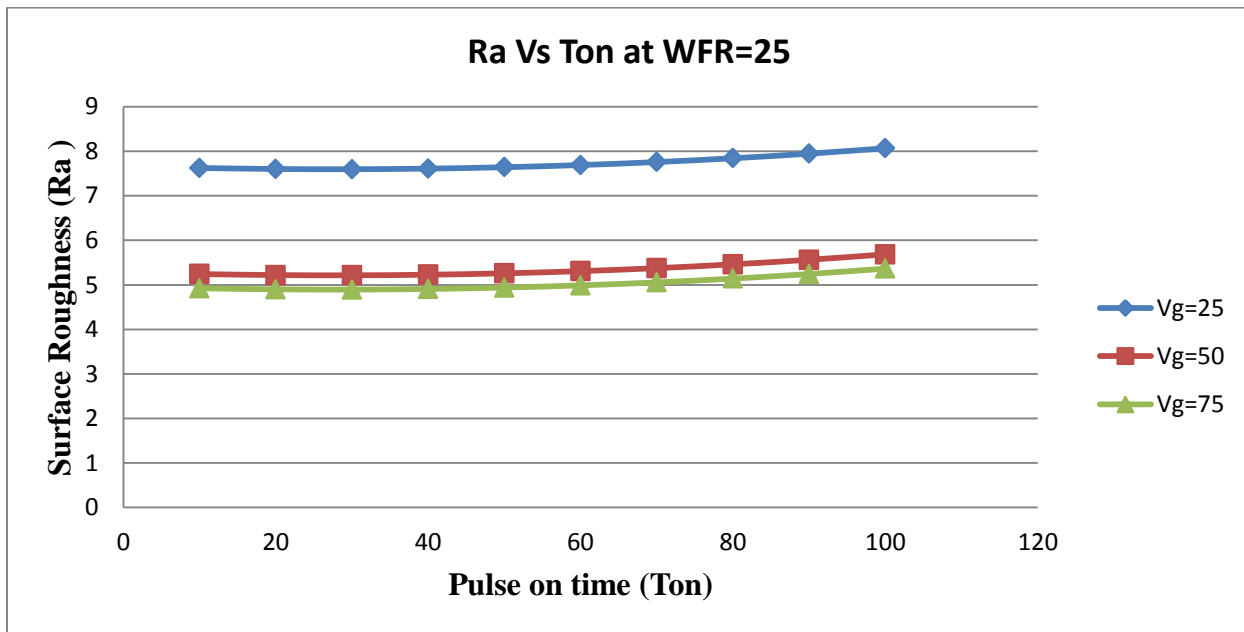

Figure 6.6: Effect of Pulse on Time on surface roughness.

Keep WFR=50

Table 6.5: Performance Measures for Pulse on Time at WFR=50 units

Ton	WFR	Vg	Ra(μm)	Vg	Ra(μm)	Vg	Ra(μm)
10	50	25	6.03683	50	3.654607	75	3.334607
20	50	25	6.014207	50	3.631985	75	3.311985
30	50	25	6.009541	50	3.627319	75	3.307319
40	50	25	6.02283	50	3.640607	75	3.320607
50	50	25	6.054074	50	3.671852	75	3.351852
60	50	25	6.103274	50	3.721052	75	3.401052
70	50	25	6.17043	50	3.788207	75	3.468207
80	50	25	6.255541	50	3.873319	75	3.553319
90	50	25	6.358607	50	3.976385	75	3.656385
100	50	25	6.47963	50	4.097407	75	3.777407

***Bold** value gives lowest surface roughness

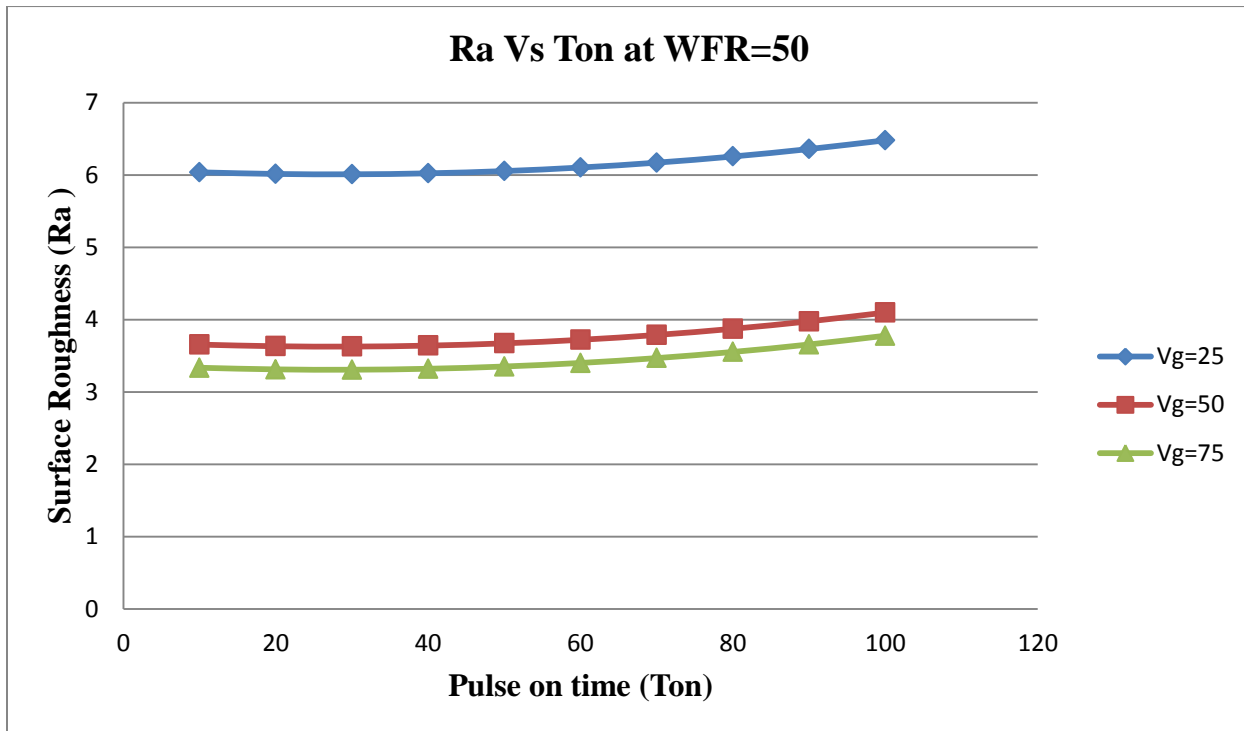

Figure 6.7: Effect of Pulse on Time on surface roughness

Table 6.6: Performance Measures for Pulse on Time at WFR=75 units

Ton	WFR	Vg	Ra(μm)	Vg	Ra(μm)	Vg	Ra(μm)
10	75	25	6.101274	50	3.719052	75	3.399052
20	75	25	6.078652	50	3.69643	75	3.37643
30	75	25	6.073985	50	3.691763	75	3.371763
40	75	25	6.087274	50	3.705052	75	3.385052
50	75	25	6.118518	50	3.736296	75	3.416296
60	75	25	6.167718	50	3.785496	75	3.465496
70	75	25	6.234874	50	3.852652	75	3.532652
80	75	25	6.319985	50	3.937763	75	3.617763
90	75	25	6.423052	50	4.04083	75	3.72083
100	75	25	6.544074	50	4.161852	75	3.841852

***Bold** value gives lowest surface roughness

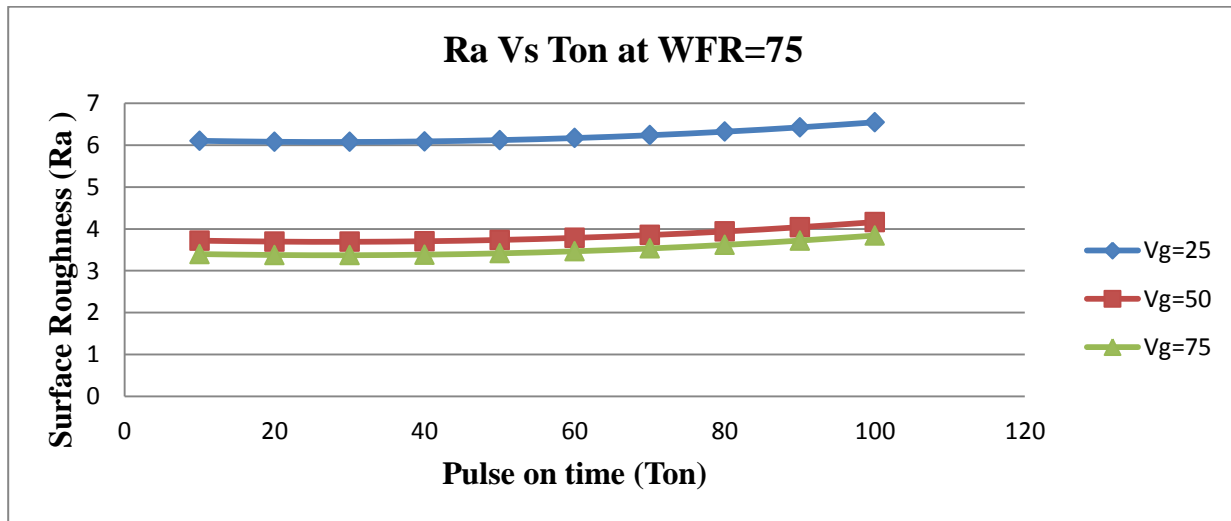

Figure 6.8: Effect of Pulse on Time on surface roughness.

The effect of pulse duration on surface finish is shown in figure 6.6, figure 6.7, & figure 6.8. In the machining range from 25 to 75 V, the surface roughness increases with pulse duration. The increase becomes more gradual after 30 μs pulse duration for all gap voltage settings.

The reason for larger roughness values with higher pulse duration can be explained by the generation of large craters due to large amounts of energy. Therefore, good surface Finish quality can only be achieved with low pulse duration.

There is usually a pulse duration at which best surface finish obtained is 30 μs .

6.4 EFFECT OF SPARK GAP VOLTAGE ON SURFACE ROUGHNESS:

The pulse on time (T_{on}) is varied from 10 units to 80 units in steps of 10 units. The values of the other parameters are kept constant and their values are given as $T_{off} = 15$ unit; $I_p = 4$ unit; group pulse = 5unit; SEN = 10; wire feed rate=60 unit; $T_{on}=30\mu s$.

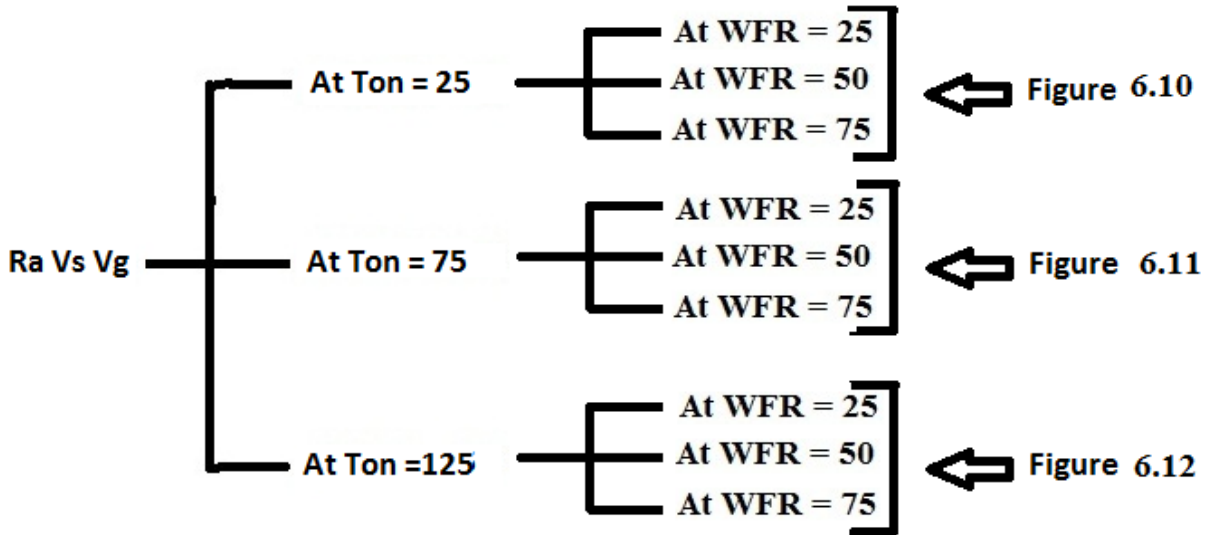

Figure 6.9 Reading tree for 3 graph each have 3 curve

The experimentally observed data for the surface roughness for different values of spark gap voltage is given in Table 6.7, 6.8 & 6.9. And figure 6.10, 6.11& 6.12 shows the scatter plots of pulse on time versus response characteristics.

Table 6.7: Performance Measures for Spark Gap Set Voltage

Vg	WFR	Ton	Ra(μm)	Ton	Ra(μm)	Ton	Ra(μm)
10	25	25	10.01661	50	8.42883	75	8.493274
20	25	25	8.321319	50	6.733541	75	6.797985
30	25	25	6.955985	50	5.368207	75	5.432652
40	25	25	5.920607	50	4.33283	75	4.397274
50	25	25	5.215185	50	3.627407	75	3.691852
60	25	25	4.839719	50	3.251941	75	3.316385
70	25	25	4.794207	50	3.20643	75	3.270874
80	25	25	5.078652	50	3.490874	75	3.555319

***Bold** value gives lowest surface roughness

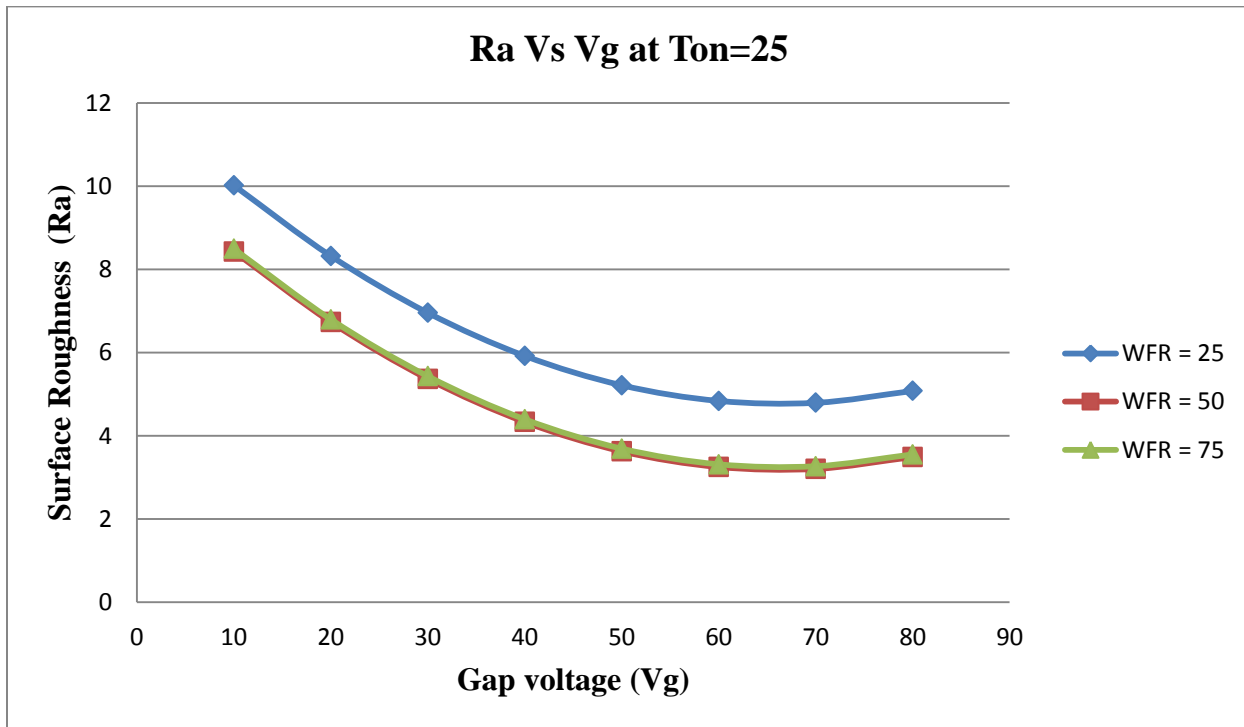

Figure 6.10: Effect of gap voltage on surface roughness

Table 6.8: Performance Measures for Spark Gap Set Voltage

Vg	WFR	Ton	Ra(μm)	Ton	Ra(μm)	Ton	Ra(μm)
10	50	25	10.06105	50	8.473274	75	8.537718
20	50	25	8.365763	50	6.777985	75	6.84243
30	50	25	7.00043	50	5.412652	75	5.477096
40	50	25	5.965052	50	4.377274	75	4.441718
50	50	25	5.25963	50	3.671852	75	3.736296
60	50	25	4.884163	50	3.296385	75	3.36083
70	50	25	4.838652	50	3.250874	75	3.315319
80	50	25	5.123096	50	3.535319	75	3.599763

***Bold** value gives lowest surface roughness

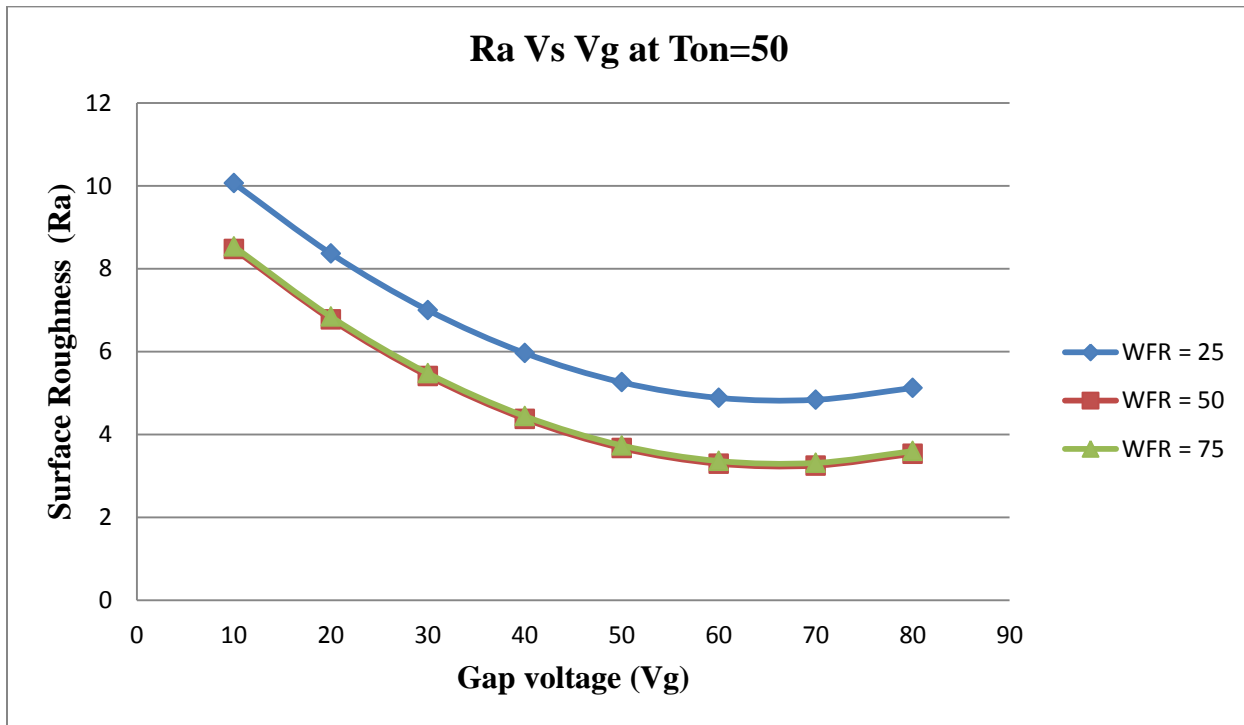

Figure 6.11: Effect of gap voltage on surface roughness

Table 6.9: Performance Measures for Spark Gap Set Voltage

Vg	WFR	Ton	Ra(μm)	Ton	Ra(μm)	Ton	Ra(μm)
10	75	25	10.21772	50	8.629941	75	8.694385
20	75	25	8.52243	50	6.934652	75	6.999096
30	75	25	7.157096	50	5.569319	75	5.633763
40	75	25	6.121719	50	4.533941	75	4.598385
50	75	25	5.416296	50	3.828519	75	3.892963
60	75	25	5.04083	50	3.453052	75	3.517496
70	75	25	4.995319	50	3.407541	75	3.471985
80	75	25	5.279763	50	3.691985	75	3.75643

***Bold** value gives lowest surface roughness

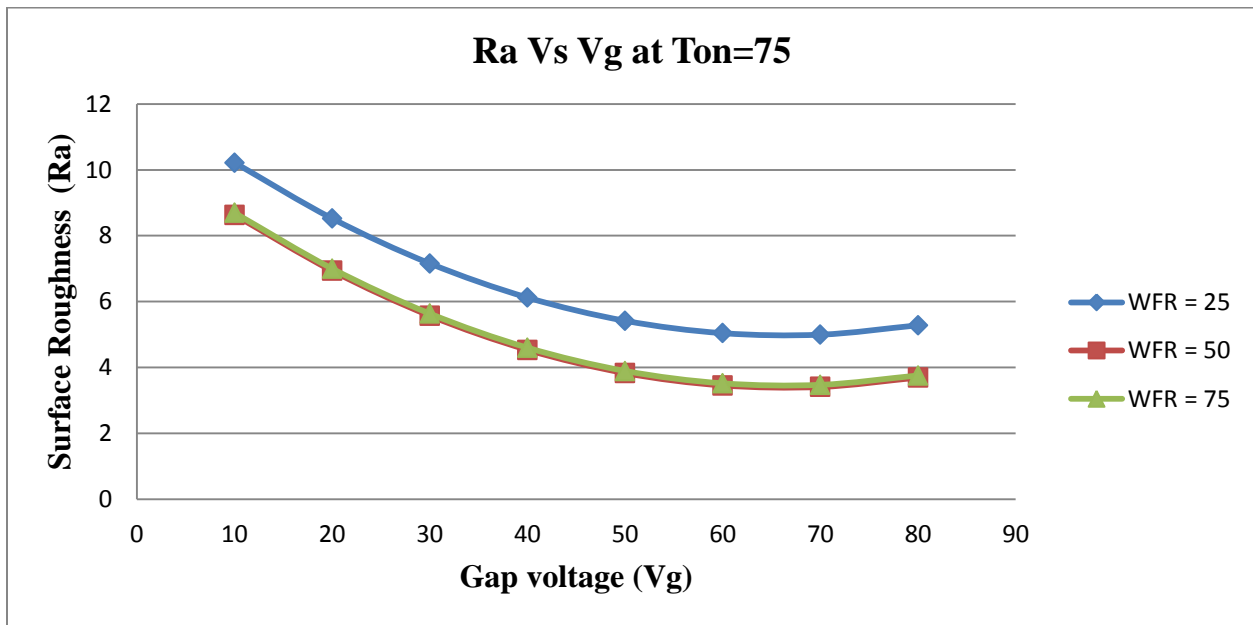

Figure 6.12: Effect of gap voltage on surface roughness

There is decrease in surface roughness with increase in gap voltage. Reason behind this, It is generally thought that as the voltage increases (the discharge energy increases), the machining rate will also increase at constant current and constant pulse-on/off time. However, too high a voltage will cause an unfavorable concentrated discharge due to insufficient cooling of the work material. Then the material removal rate will decrease that is why surface roughness will decrease.

6.5 EFFECT OF SPARK GAP VOLTAGE OVER WIRE FEED RATE:

Here first find the second order polynomial nonlinear equation then we check nature of wire feed rate on variation of other parameter like pulse on time and gap voltage at different fixed surface roughness value.

Here three graph are drawn at three different value pulse on time (i.e. 25, 50, 75) and every graph have three curve at three different value of surface roughness (i.e. 2,4,6). For this equation 5.2 used in which two variable kept constant. In this type we see the behavior of wire feed rate on variation in gap voltage.

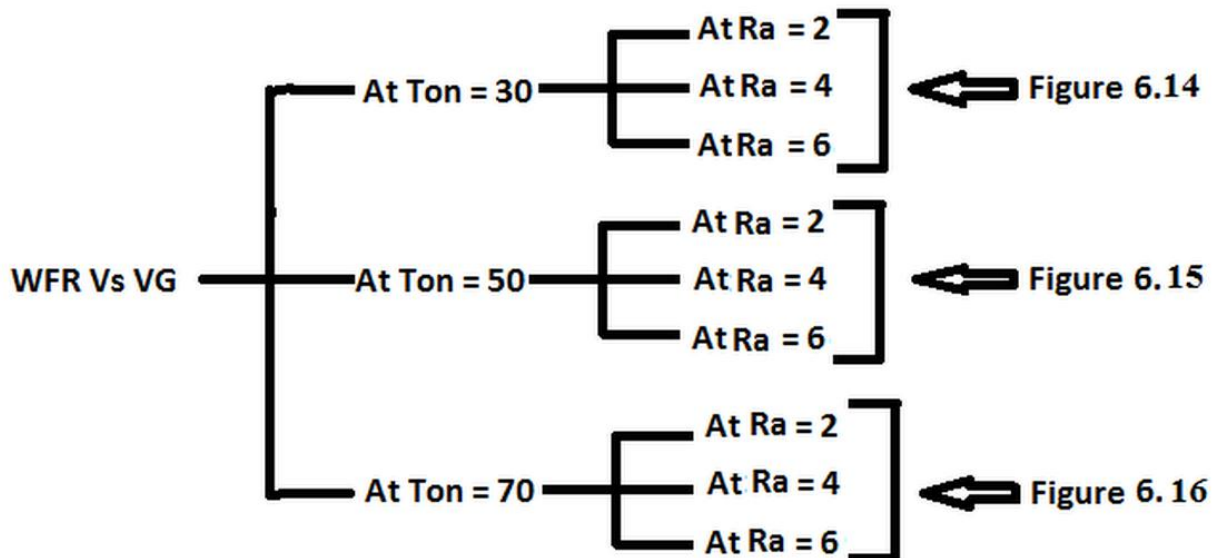

Figure 6.13 Reading tree for 3 graphs with each have 3 curves

Keep Ton =30 Constant

Table 6.10: Variation in feed at different surface roughness when gap voltage changes.

Vg (V)	Ton(μ s)	Ra(μ m)	WFR(m/min)	Ra(μ m)	WFR(m/min)	Ra(μ m)	WFR(m/min)
10	30	2	171.6252	4	128.7946	6	94.46687
20	30	2	145.3236	4	102.493	6	68.16531
30	30	2	124.0616	4	81.23105	6	46.90331
40	30	2	107.8392	4	65.00864	6	30.6809
50	30	2	96.65639	4	53.8258	6	19.49806
60	30	2	90.51313	4	47.68253	6	13.35479
70	30	2	89.40944	4	46.57884	6	12.2511
80	30	2	93.34532	4	50.51473	6	16.18699
90	30	2	102.3208	4	59.49019	6	25.16245

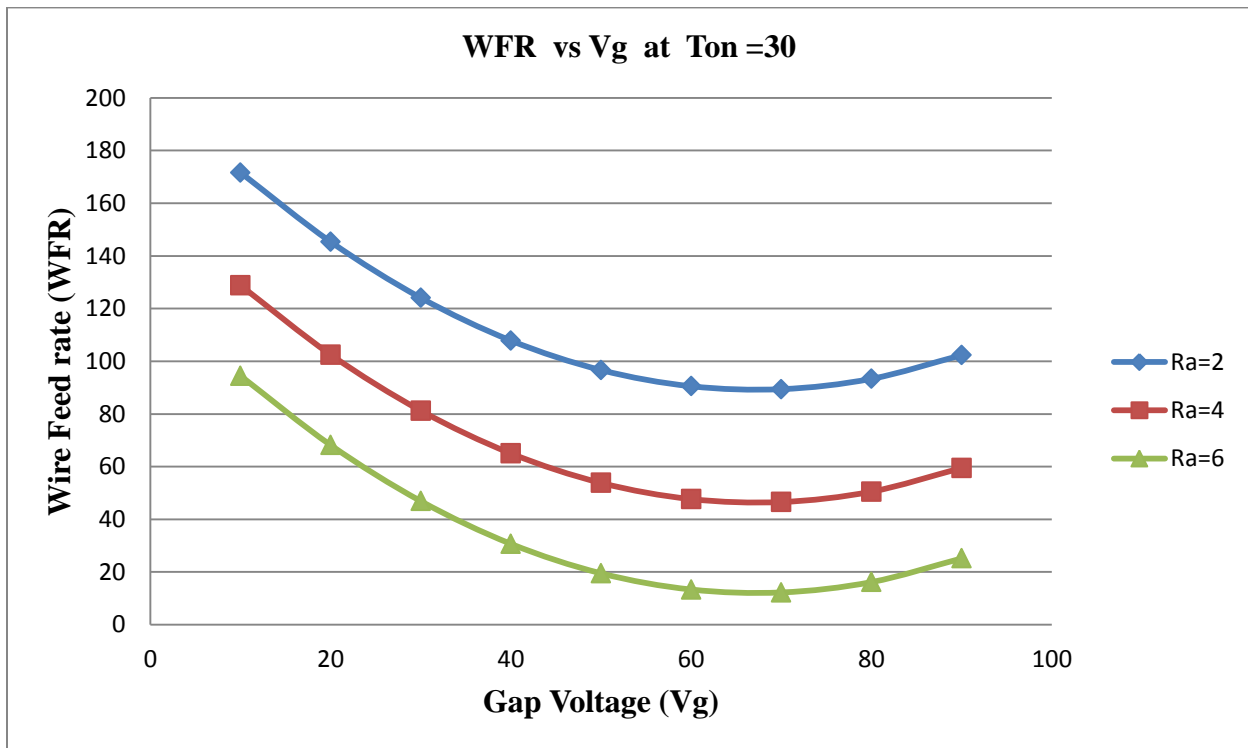

Figure 6.14: Effect of gap voltage over wire feed rate at Ton =30

Keep Ton =50 (Constant)

Table 6.11: Variation in feed at different surface roughness when gap voltage changes

Vg (V)	Ton(μ s)	Ra(μ m)	WFR(m/min)	Ra(μ m)	WFR(m/min)	Ra(μ m)	WFR(m/min)
10	50	2	171.2567	4	128.4261	6	94.09838
20	50	2	144.9552	4	102.1246	6	67.79682
30	50	2	123.6932	4	80.86257	6	46.53483
40	50	2	107.4707	4	64.64015	6	30.31241
50	50	2	96.2879	4	53.45731	6	19.12957
60	50	2	90.14464	4	47.31404	6	12.9863
70	50	2	89.04095	4	46.21035	6	11.88261
80	50	2	92.97683	4	50.14624	6	15.8185
90	50	2	101.9523	4	59.1217	6	24.79396

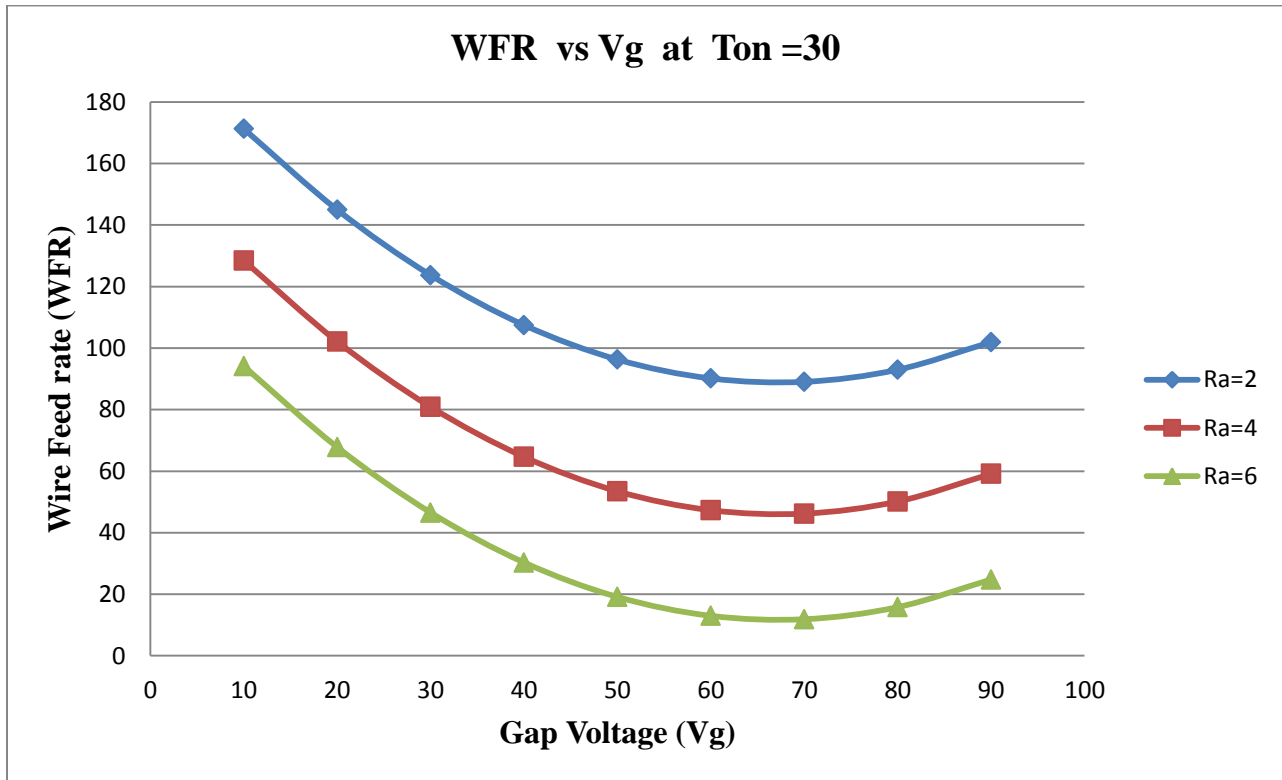

Figure 6.15: Effect of gap voltage over wire feed rate at Ton =50

Keep Ton =70 (Constant)

Table 6.12: variation in feed at different surface roughness when gap voltage changes

Vg (V)	Ton(μ s)	Ra(μ m)	WFR(m/min)	Ra(μ m)	WFR(m/min)	Ra(μ m)	WFR(m/min)
10	70	2	172.5919	4	129.7613	6	95.43359
20	70	2	146.2904	4	103.4598	6	69.13203
30	70	2	125.0284	4	82.19778	6	47.87004
40	70	2	108.806	4	65.97536	6	31.64762
50	70	2	97.62311	4	54.79252	6	20.46478
60	70	2	91.47985	4	48.64925	6	14.32151
70	70	2	90.37616	4	47.54556	6	13.21782
80	70	2	94.31204	4	51.48145	6	17.15371
90	70	2	103.2875	4	60.45691	6	26.12917

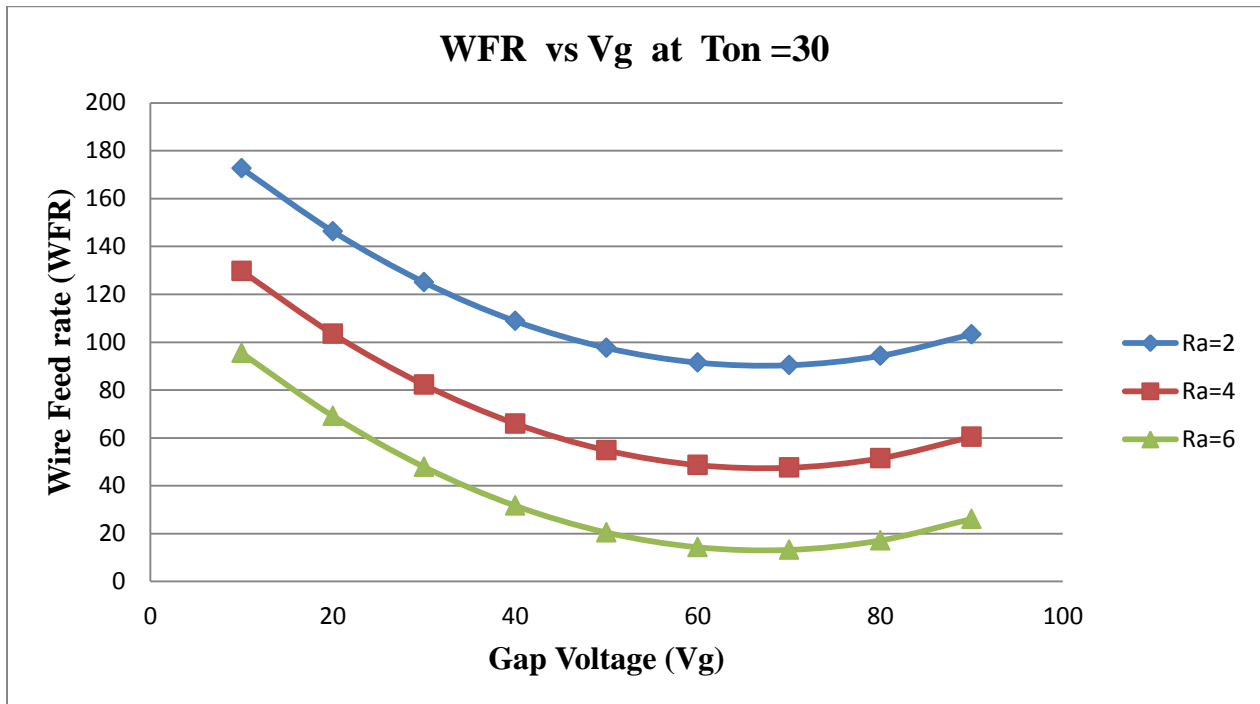

Figure 6.16: Effect of gap voltage over wire feed rate at Ton =70

As per above mentioned graph it is seen that for a fixed value of surface roughness, on increase in gap voltage wire feed rate first decreases up to 65 volt (approx.) after that increases. And on increase in surface roughness wire feed rate goes on decreasing for a fixed value of gap voltage.

6.6 EFFECT OF PULSE ON TIME OVER WIRE FEED RATE:

Here three graph are drawn at three different value gap voltage (i.e. 25, 50, 75) and every graph have three curve at three different value of surface roughness (i.e. 2,4,6) . For this equation 5.2 used in which two variable kept constant. In this type we see the behavior of wire feed rate on variation in pulse on time.

This is shown in fallowing tree diagram.

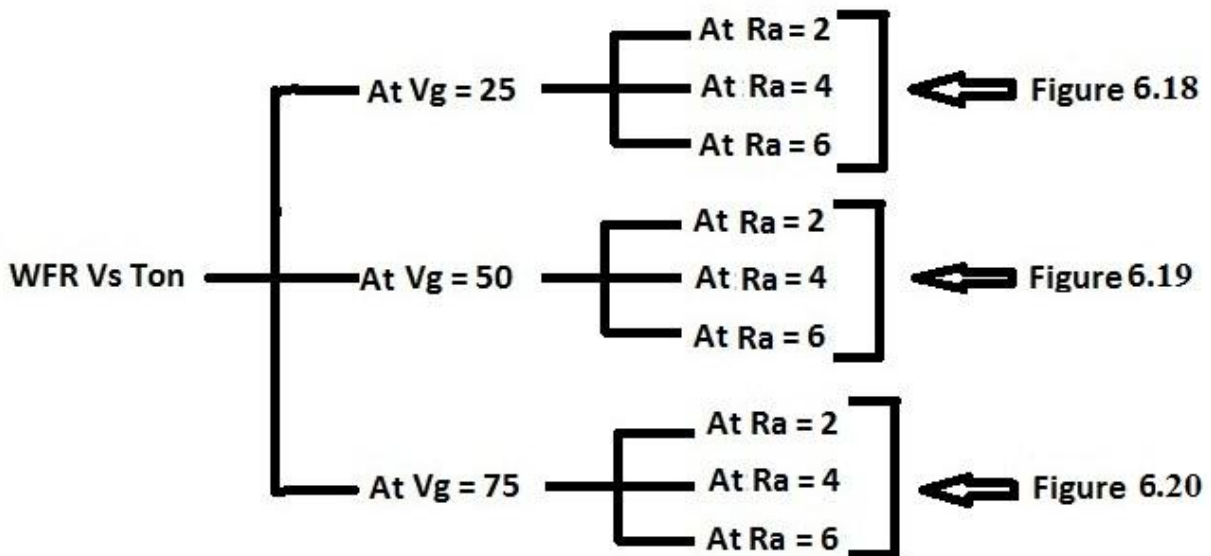

Figure 6.17: Reading tree for 3 graphs with each have 3 curves

Keep $V_g=25$ (Constant)

Table 6.13: Variation in feed at different surface roughness when pulse on time changes.

Ton(μ s)	Vg (V)	Ra(μ m)	WFR(m/min)	Ra(μ m)	WFR(m/min)	Ra(μ m)	WFR(m/min)
10	25	2	136.1349	4	93.30429	6	58.97655
20	25	2	134.8858	4	92.05524	6	57.72749
30	25	2	134.0627	4	91.2321	6	56.90436
40	25	2	133.6655	4	90.8349	6	56.50716
50	25	2	133.6942	4	90.86361	6	56.53587
60	25	2	134.1489	4	91.31826	6	56.99052
70	25	2	135.0294	4	92.19883	6	57.87108
80	25	2	136.3359	4	93.50532	6	59.17758
90	25	2	138.0683	4	95.23774	6	60.91

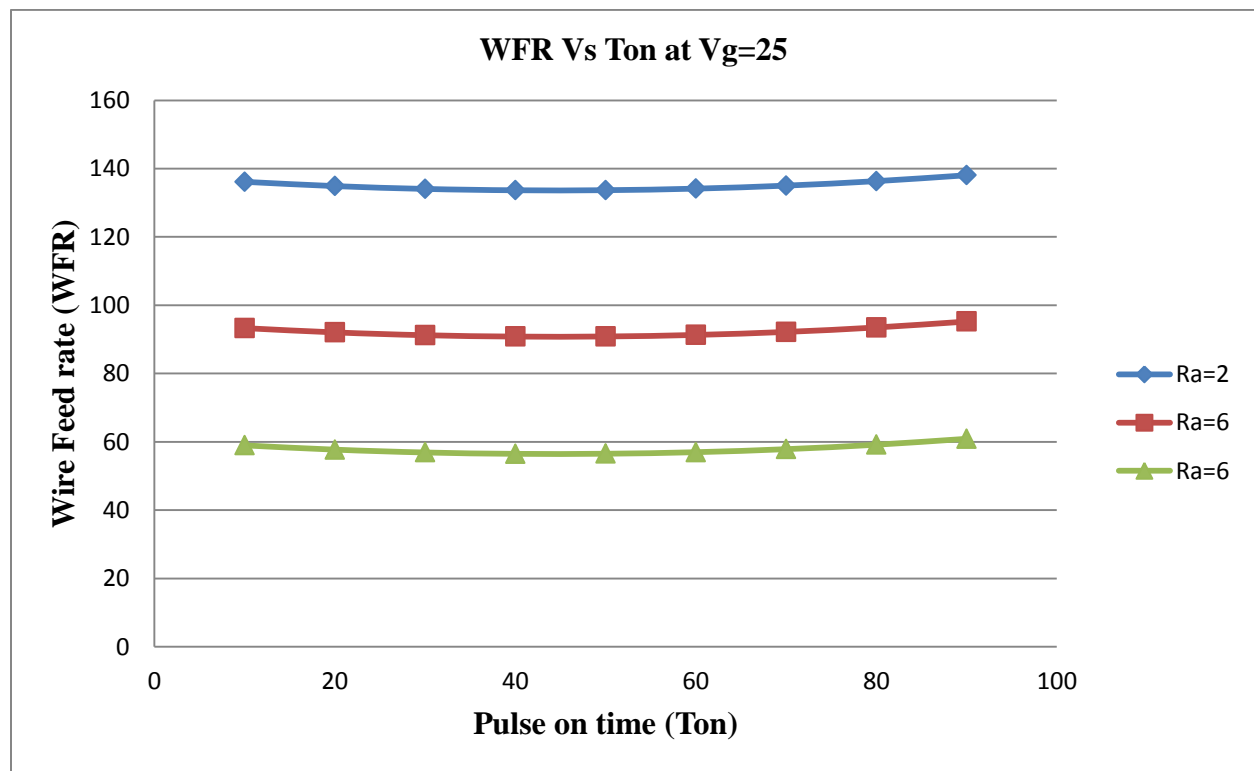

Figure 6.18: Effect of gap voltage over wire feed rate at $V_g=25$

Keep $V_g=50$ (Constant)

Table 6.14: Variation in feed at different surface roughness when pulse on time changes.

Ton(μ s)	Vg (V)	Ra(μ m)	WFR(m/min)	Ra(μ m)	WFR(m/min)	Ra(μ m)	WFR(m/min)
10	50	2	98.72858	4	55.89799	6	21.57025
20	50	2	97.47952	4	54.64893	6	20.32119
30	50	2	96.65639	4	53.8258	6	19.49806
40	50	2	96.25919	4	53.42859	6	19.10085
50	50	2	96.2879	4	53.45731	6	19.12957
60	50	2	96.74255	4	53.91195	6	19.58421
70	50	2	97.62311	4	54.79252	6	20.46478
80	50	2	98.92961	4	56.09901	6	21.77127
90	50	2	100.662	4	57.83143	6	23.50369

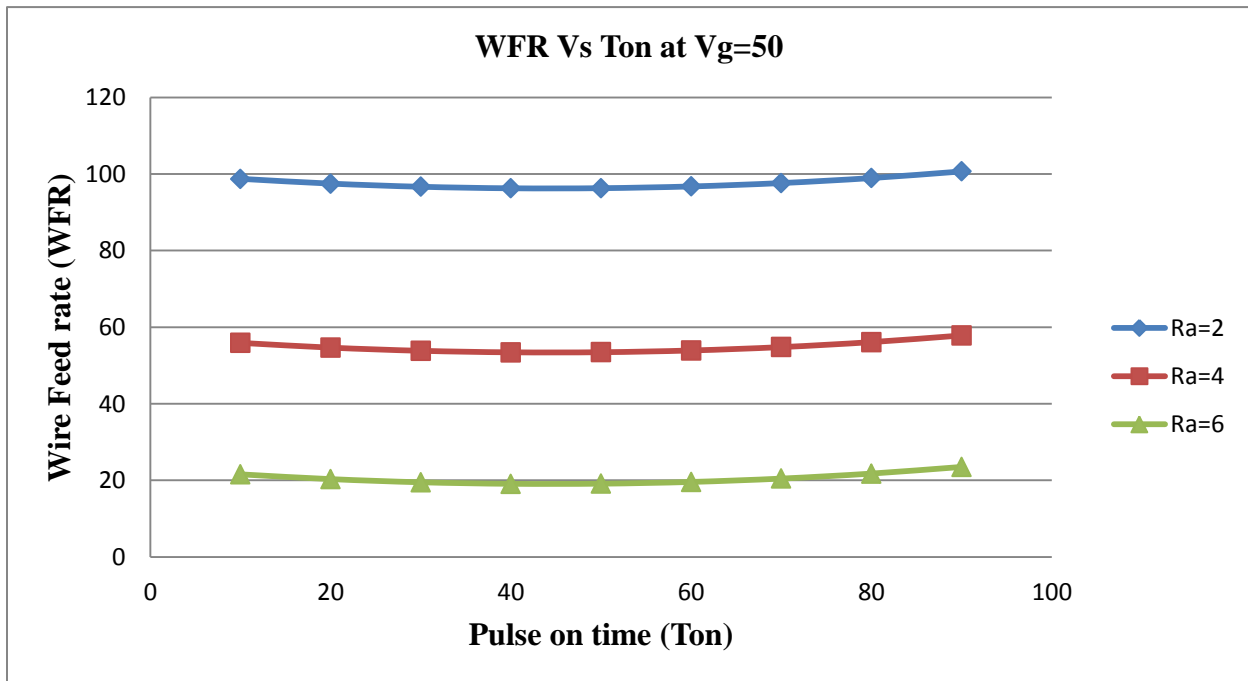

Figure 6.19: Effect of gap voltage over wire feed rate at $V_g=50$

Keep $V_g=75$ (Constant)

Table 6.15: Variation in feed at different surface roughness when pulse on time changes.

Ton(μ s)	Vg (V)	Ra(μ m)	WFR(m/min)	Ra(μ m)	WFR(m/min)	Ra(μ m)	WFR(m/min)
10	75	2	92.81962	4	49.98903	6	15.66129
20	75	2	91.57056	4	48.73997	6	14.41223
30	75	2	90.74743	4	47.91684	6	13.5891
40	75	2	90.35023	4	47.51963	6	13.19189
50	75	2	90.37894	4	47.54835	6	13.22061
60	75	2	90.83359	4	48.00299	6	13.67525
70	75	2	91.71415	4	48.88356	6	14.55582
80	75	2	93.02065	4	50.19005	6	15.86231
90	75	2	94.75306	4	51.92247	6	17.59473

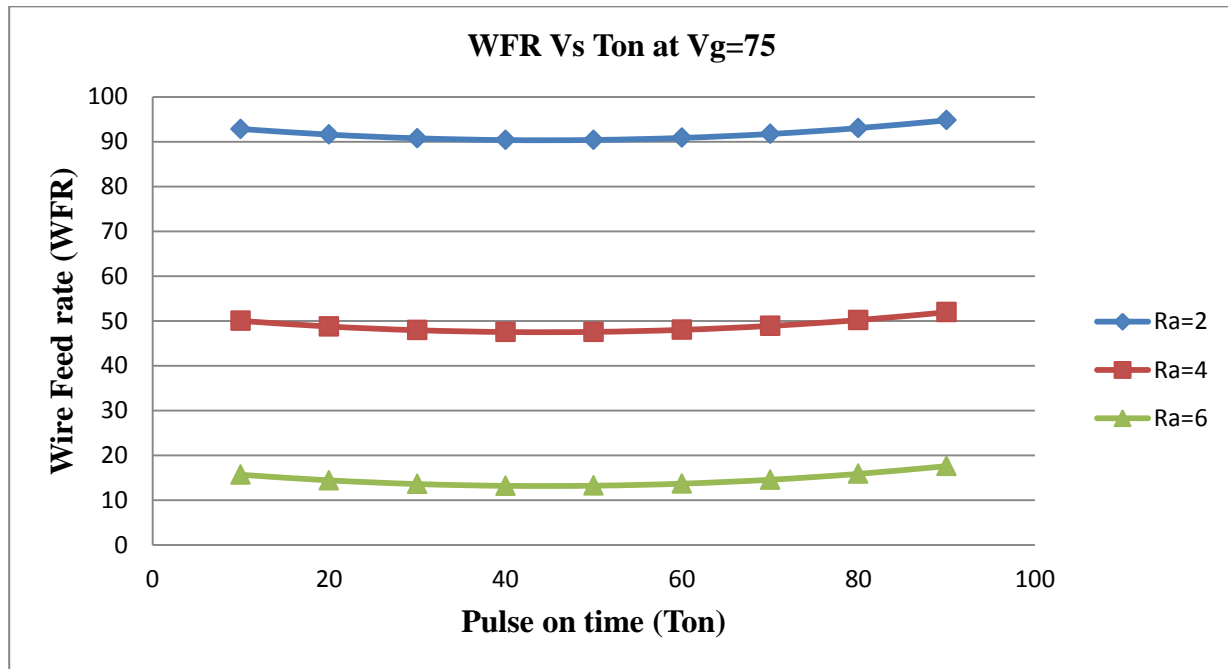

Figure 6.20: Effect of gap voltage over wire feed rate at $V_g=75$

From figure 6.18, figure 6.19 and figure 6.20, it can be observed that for a fixed value of surface roughness, on increase in pulse on time wire feed rate first slowly decreases then increases with faster rate. And on increase in surface roughness wire feed rate decreases for a fixed value of pulse on time.

6.7 EFFECT OF PULSE ON TIME ON GAP VOLTAGE:

Again find the second order polynomial nonlinear equation V_g in term of WFR, Ton & Ra then fix the two variables i.e. WFR and SR. And in this type we see the behaviour of gap voltage on variation in pulse on time.

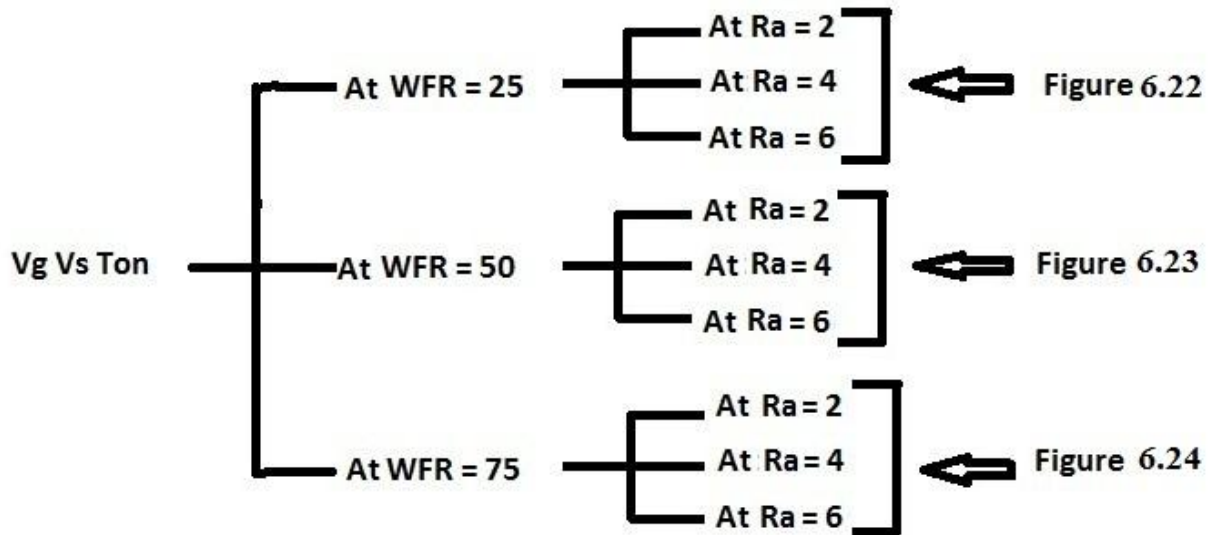

Figure 6.21: Reading tree for 3 graphs with each have 3 curves

Keep WFR=25 (Constant)

Table 6.16: Variation in Pulse on time at different surface roughness when gap voltage changes

Ton(μ s)	WFR(m/min)	Ra(μ m)	Vg (V)	Ra(μ m)	Vg (V)	Ra(μ m)	Vg (V)
10	25	2	119.9793	4	77.82223	6	47.72203
20	25	2	118.4183	4	76.2612	6	46.161
30	25	2	117.2944	4	75.13736	6	45.03716
40	25	2	116.6078	4	74.4507	6	44.3505
50	25	2	116.3583	4	74.20123	6	44.10103
60	25	2	116.546	4	74.38894	6	44.28874
70	25	2	117.1709	4	75.01383	6	44.91363
80	25	2	118.233	4	76.07591	6	45.97571
90	25	2	119.7322	4	77.57516	6	47.47496

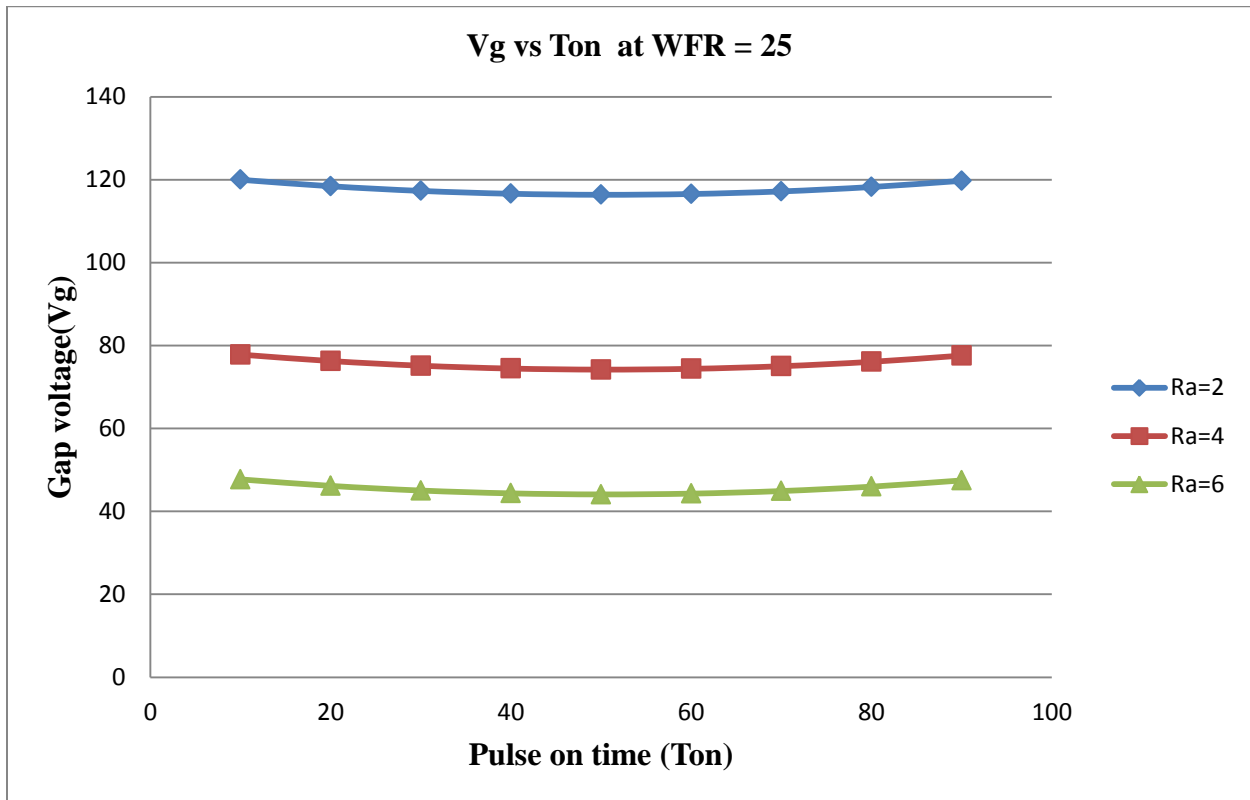

Figure 6.22: Effect of pulse on time over gap voltage at WFR=25

Keep WFR=50 (Constant)

Table 6.17: Variation in Pulse on time at different surface roughness when gap voltage changes

Ton(μ s)	WFR(m/min)	Ra(μ m)	Vg (V)	Ra(μ m)	Vg (V)	Ra(μ m)	Vg (V)
10	50	2	100.1512	4	57.99415	6	27.89395
20	50	2	98.5902	4	56.43313	6	26.33293
30	50	2	97.46636	4	55.30929	6	25.20909
40	50	2	96.7797	4	54.62263	6	24.52243
50	50	2	96.53023	4	54.37316	6	24.27296
60	50	2	96.71794	4	54.56086	6	24.46066
70	50	2	97.34283	4	55.18576	6	25.08556
80	50	2	98.4049	4	56.24783	6	26.14763
90	50	2	99.90416	4	57.74709	6	27.64689

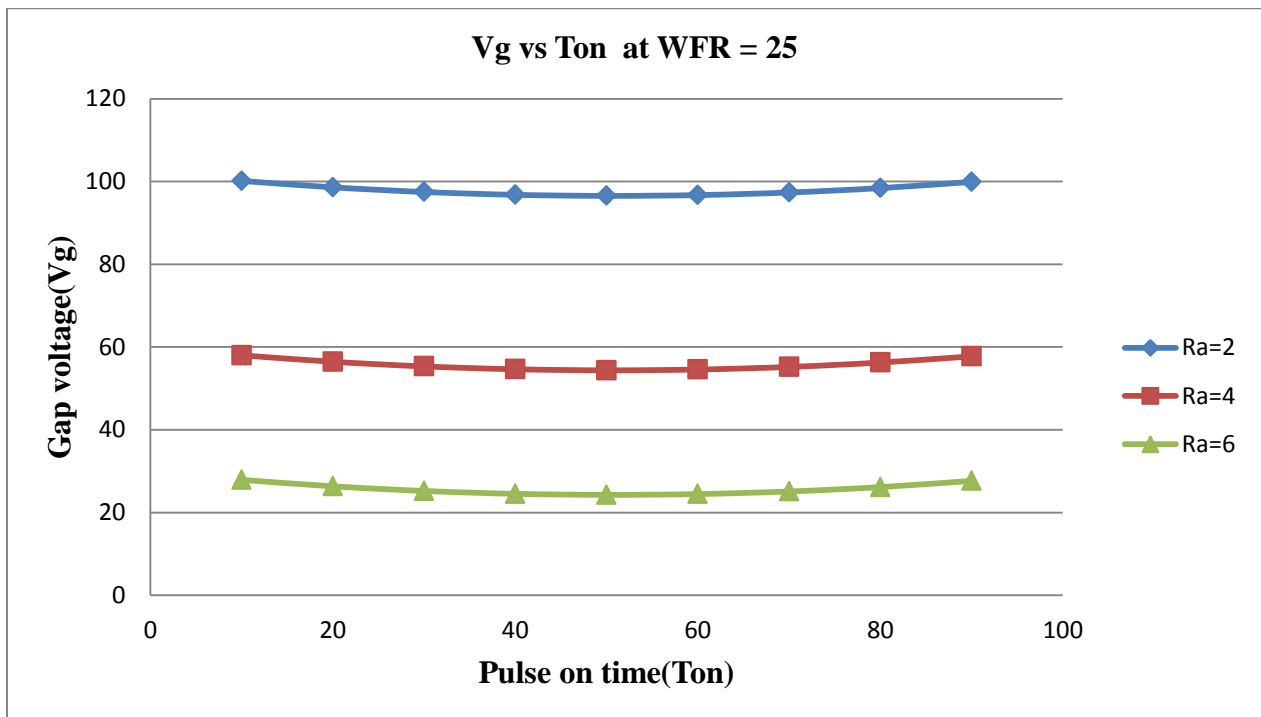

Figure 6.23: Effect of pulse on time over gap voltage at WFR=50

Keep WFR=75 (Constant)

Table 6.18: Variation in Pulse on time at different surface roughness when gap voltage changes

Ton(μ s)	WFR(m/min)	Ra(μ m)	Vg (V)	Ra(μ m)	Vg (V)	Ra(μ m)	Vg (V)
10	75	2	101.2174	4	59.06037	6	28.96017
20	75	2	99.65642	4	57.49934	6	27.39914
30	75	2	98.53258	4	56.3755	6	26.2753
40	75	2	97.84592	4	55.68885	6	25.58865
50	75	2	97.59644	4	55.43937	6	25.33917
60	75	2	97.78415	4	55.62708	6	25.52688
70	75	2	98.40904	4	56.25197	6	26.15177
80	75	2	99.47112	4	57.31405	6	27.21385
90	75	2	100.9704	4	58.81331	6	28.71311

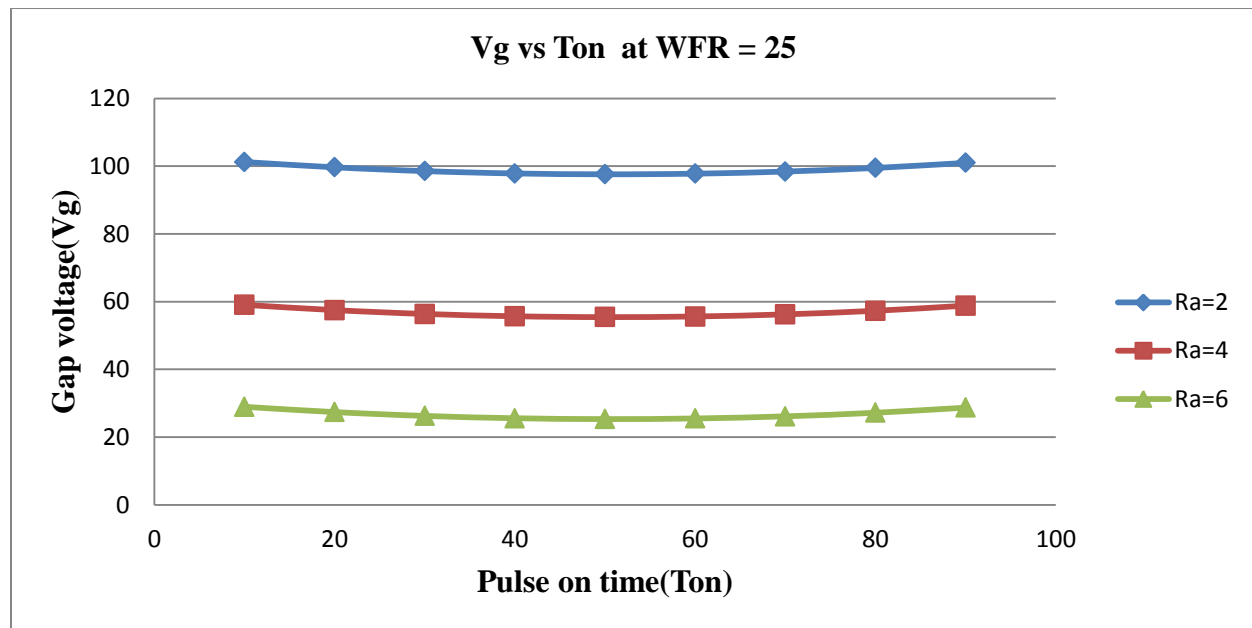

Figure 6.24: Effect of pulse on time over gap voltage at WFR=75

From figure 6.22, figure 6.23 & figure 6.24, it is seen that for a fixed value surface roughness on increase in pulse on time, gap voltage first slowly decreases then slowly increases. And for a fixed value of pulse on time, gap voltage should be higher for better surface finish.

CHAPTER 7

CONCLUSION

In this experimental study, the effect of WEDM parameters such as open circuit voltage, wire feed rate, pulse duration and spark gap voltage on machining characteristics of AISI D3 steel was investigated. Summarizing the main features of the results, the following conclusions may be drawn:

1. There is decrease in surface roughness with increase in wire feed rate because of formation of small crater over machined surface. This is because of less time available for spark concentration.
2. There is increase in material removal rate with pulse duration at all gap voltage settings. The machined workpiece surface roughness increases steadily with increasing pulse duration.
3. On increase in pulse on time, gap voltage first slowly decreases then slowly increases. And for a fixed value of pulse on time, gap voltage should be higher for better surface finish.

REFERNCES

- [1] Y.F. Luo, “An energy-distribution strategy in fast-cutting wire EDM”, *Journal of Materials Processing Technology*, vol.55, (1995), pp. 380-390.
- [2] Ivano Belranfi et al. “A simplified post process for wire cut EDM” ,*Journal of Materials Processing Technology*, vol. 58, (1996), pp. 385-389.
- [3] Y.K. LOK, T. C. LEE,” Processing of Advanced Ceramics Using the Wire-Cut EDM process”, *Journal of Materials Processing Technology*, vol. 63, (1997), pp. 839-843.
- [4] Brian K. Rhoney, Albert J. Shih, et al.” Wear mechanism of metal bond diamond wheels trued by wire electrical discharge machining”, *Wear* vol. 252, (2002), pp. 644–653.
- [5] Y.S. Liao , J.T. Huang , Y.H. Chen(2004), “A study to achieve a fine surface finish in Wire-EDM “,*Journal of Materials Processing Technology*, vol. 149, (2004), pp. 165–171.
- [6] Mu-Tian Yan , Pin-Hsum Huang, “Accuracy improvement of wire-EDM by real-time wire tension control”, *International Journal of Machine Tools & Manufacture*, vol.44, (2004) pp. 807–814.
- [7] Ahmet Hascalyk , Ulas Cayda, “Experimental study of wire electrical discharge machining of AISI D5 tool steel”, *Journal of Materials Processing Technology*, vol.148, (2004), pp. 362–367.
- [8] K.H. Ho, S.T. Newman, et al., “State of the art in wire electrical discharge machining (WEDM)”, *International Journal of Machine Tools & Manufacture* 44 (2004) 1247–1259.
- [9] Jerzy Kozak , et al.” Machining of low electrical conductive materials by wire electrical discharge machining (WEDM)”,*Journal of Materials Processing Technology*, vol. 149, (2004), pp. 266–271.
- [10] Hideo Takino a, et al.” Cutting of polished single-crystal silicon by wire electrical discharge machining”, *Precision Engineering*, vol. 28, (2004), pp. 314–319.
- [11] Hideo Takino et al.” High-quality cutting of polished single-crystal silicon by wire electrical discharge machining” ,*Precision Engineering*, vol. 29, (2005) pp. 423–430.

- [12] S. Sarkar, S. Mitra, B. Bhattacharyya ,”Parametric analysis and optimization of wire electrical discharge machining of γ -titanium aluminide alloy”, Journal of Materials Processing Technology, vol. 159, (2005), pp. 286–294.
- [13] S. Sarkar, S. Mitra ,B. Bhattacharyya, “Parametric optimisation of wire electrical discharge machining of γ -titanium aluminide alloy through an artificial neural network model”, Int J Adv Manuf Technol, vol. 27, (2006), pp. 501–508.
- [14] Bert Lauwers, Weidong Liu, and Wesley Eeraerts ,”Influence of the Composition of WC-Based Cermets on Manufacturability by Wire-EDM”, Journal of Manufacturing Processes, Vol.8/No.2 (2006), pp. 83-89.
- [15] K. Kanlayasiri, S. Boonmung, “An investigation on effects of wire-EDM machining parameters on surface roughness of newly developed DC53 die steel”, Journal of Materials Processing Technology, vol.187 (2007), pp. 26–29.
- [16] K. Kanlayasiri, S. Boonmung, “Effects of wire-EDM machining variables on surface roughness of newly developed DC 53 die steel: Design of experiments and regression model” , Journal of Materials Processing Technology, vol.192 (2007), pp. 459–464.
- [17] Spiros Zinelis,” Surface and elemental alterations of dental alloys induced by electro discharge machining (EDM)”, Dental materials, vol. 23 (2007), pp. 601–607.
- [18] Mu-Tian Yan, Yi-Peng Lai,” Surface quality improvement of wire-EDM using a fine-finish power supply” ,International Journal of Machine Tools & Manufacture, vol. 47 (2007), pp. 1686–1694.
- [19] Mohammad Jafar Haddada, Alireza Fadaei Tehrani , “Investigation of cylindrical wire electrical discharge turning (CWEDT) of AISI D3 tool steel based on statistical analysis”, journal of materials processing technology, vol. 198, (2008), pp. 77–85.
- [20] I.Cabanesa, E. Portilloa , M. Marcos , J.A. Sanchez ,” On-line prevention of wire breakage in wire electro-discharge machining”, Robotics and Computer-Integrated Manufacturing, vol. 24 (2008), pp.287–298.

- [21] Probir Saha & Abhijit Singha & Surjya K. Pal & Partha Saha, “Soft computing models based prediction of cutting speed and surface roughness in wire electro-discharge machining of tungsten carbide cobalt composite”, *Int J Adv Manuf Technol*, vol.39, (2008), pp. 74–84.
- [22] Thomas R. Newton, etal. “Investigation of the effect of process parameters on the formation and characteristics of recast layer in wire-EDM of Inconel 718”, *Materials Science and Engineering*, vol. A 513 (2009), pp.208–215.
- [23] Mu-Tian Yan , Yi-Ting Liu , “Design, analysis and experimental study of a high-frequency power supply for finish cut of wire-EDM”, *International Journal of Machine Tools & Manufacture*, vol. 49, (2009), pp. 793–796.
- [24] Dinesh Rakwal, Eberhard Bamberg, “Slicing, cleaning and kerf analysis of germanium wafers machined by wire electrical discharge machining”, *journal of materials processing technology*, vol. 209, (2009), pp. 3740–3751.