

**Thermodynamic Analysis of Combined Cycle Gas Turbine for Improving Its
Thermal Performance**

A major thesis submitted in the partial fulfillment of the requirement
for the award of the degree of
Master of Technology
In
Thermal Engineering



Submitted by

AMIT SINGH

ROLL NO. 2K15/THE/01

SESSION 2015-17

Under the Guidance of

Dr. R. S. MISHRA

Professor

(Head of Department)

Department of Mechanical, Production & Industrial Engineering
DELHI TECHNOLOGICAL UNIVERSITY, Shahbad Daulatpur,
Main Bawana Road, Delhi – 110042

CANDIDATE'S DECLARATION

I hereby declare that the project entitled “**Thermodynamic Analysis of Combined Cycle Gas Turbine for Improving Its Thermal Performance**” being submitted by me is an authentic work carried out under the supervision of **Dr. R.S. Mishra**, Professor and HOD Mechanical Engineering Department, Delhi Technological University, New Delhi.

The matter embodied in this dissertation report has not been submitted by me for the award of any other degree or diploma.

AMIT SINGH

(2K15/THE/01)

CERTIFICATE

This is to certify that the report entitled “**Thermodynamic Analysis of Combined Cycle Gas Turbine for Improving Its Thermal Performance**” submitted by **AMIT SINGH (2K15/THE/01)** in partial fulfilment for the award of Master of Technology in Thermal Engineering, is an authentic record of student’s own work carried out under my guidance and supervision.

(Dr. R. S. MISHRA)

Professor, HOD Mechanical Engineering

Delhi Technology University, Delhi-110042

ACKNOWLEDGEMENT

It is a great pleasure to have the opportunity to express my heartiest felt gratitude to everybody who helped me throughout the course of this dissertation.

The feeling of acknowledgement and its expression in words are entirely different. It is a matter of profound privilege and pleasure to express my deep sense of gratitude and indebtedness to my guide **Dr. R.S. Mishra**, Professor in the Department of Mechanical engineering, Department of Mechanical Engineering, Delhi Technological University (Formerly Delhi College of Engineering), for there invaluable guidance, encouragement and patient review. Their continuous inspiration only has made me complete this project.

I would also like to take this opportunity to present my sincere regards to all my teachers for their kind support and encouragement.

Last, but not the least, I would like to mention that all the blessing and affection of my parents, my colleagues and my seniors encouraged me to always work hard.

AMIT SINGH

(2K15/THE/01)

CONTENTS

	Title	Page No.
CHAPTER 1	INTRODUCTION	1-8
1.1	Combined Cycle Gas Turbine Technology	1
1.2	Combined-Cycle Gas Turbine Features	2-3
1.3	Thermodynamic description	3-8
1.4	Motivation of the Present Research Work	8
1.5	Organization of the Report	8
CHAPTER 2	LITERATURE REVIEW	9-16
2.1	Summary of Literature Review	10-15
2.2	Conclusions of Literature Review	15-16
2.3	Objectives of the Present Research Work	16
CHAPTER 3	THERMODYNAMIC ANALYSIS AND FORMULATION OF COMBINED GAS TURBINE	17-27
3.1	Combined Cycle Gas Turbine Description	17-20
3.2	Mathematical Formulation	20-27
3.2.1	Low Pressure Compressor	21
3.2.2	Intercooler	21
3.2.3	High Pressure Compressor	22
3.2.4	Combustion Chamber	22
3.2.5	High Pressure Gas Turbine	23
3.2.6	Duct Burner	23
3.2.7	Low Pressure Gas Turbine	24
3.2.8	Heat Recovery Steam Generator	24
3.2.9	High Pressure Steam Turbine	25
3.2.10	Low Pressure Steam Turbine	25
3.2.11	Condenser	26
3.2.11	Pump	27
CHAPTER 4	SIMULATION STUDIES AND RESULTS	28-46
4.1	Solution Methodology	28
4.2	Model Validation	28-34
4.3	Parametric Studies	35-46
CHAPTER 5	CONCLUSION AND RECOMMENDATION	47-48
	REFERENCES	49-51

LIST OF TABLES

3.1	description of different states corresponding to figure 3.1	18
3.2	description of different states corresponding to figure 3.2	19-20
4.1	Input data for analysis of simple combined cycle gas turbine system	29-30
4.2	Results obtained from analysis of simple combined cycle system	30
4.3	Input data for analysis of modified combined cycle System	31
4.4	results obtained from modified combined cycle system	32-33

LIST OF FIGURES

SI. NO	TITLE	PAGE
1.1	A closed cycle gas turbine	3
1.2	T-s diagram of Brayton cycle	3
1.3	open regenerative Brayton cycle	4
1.4	T-s diagram of open regenerative Brayton cycle	4
1.5	open Brayton cycle with intercooling	5
1.6	T-s diagram of open Brayton cycle with intercooling, reheating and regeneration	5
1.7	simple Rankine cycle	6
3.1	Simple combined cycle gas turbine	17
3.2	combined cycle gas turbine (in present analysis)	19
4.1	Simple combined cycle gas turbine	29
4.2	modified combined cycle system	31
4.3	% Exergy destruction of total Exergy destruction in different components	34
4.4	Exergy destruction rate in different components	34
4.5	Variation of first law efficiency with overall pressure ratio in gas turbine	38
4.6	Variation of second law efficiency with overall pressure ratio in gas turbine	39
4.7	effect of pressure ratio in low pressure compressor on first law efficiency	39
4.8	effect of pressure ratio in low pressure compressor on second	40

	law efficiency	
4.9	effect of pressure ratio in high pressure gas turbine on first law efficiency	40
4.10	effect of pressure ratio in high pressure gas turbine on second law efficiency	41
4.11	effect of gas turbine inlet temperature on first law efficiency	41
4.12	effect of gas turbine inlet temperature on second law efficiency	42
4.13	effect of steam turbine pressure on first law efficiency	42
4.14	effect of steam turbine pressure on second law efficiency	43
4.15	effect of pressure ratio of high pressure steam turbine on first law efficiency	43
4.16	effect of pressure ratio of high pressure steam turbine on second law efficiency	44
4.17	effect of steam turbine inlet temperature on first law efficiency	44
4.18	effect of steam turbine inlet temperature on second law efficiency	45
4.19	effect of compressor inlet air temperature on first law efficiency	45
4.20	effect of compressor inlet air temperature on second law efficiency	46

ABSTRACT

The objective of the presented work is to develop a Thermodynamic optimization method in order to optimize the efficiency of a combined cycle gas turbine (CCGT) power plant and suggest ways of improving the efficiency.

The Thermodynamic analysis provides a complete diagnosis of the performance of the combined cycle power plant, both in energetic and in exergetic terms. The system considered in this thesis is a combined cycle power plant which couples the two power cycles, Brayton cycle (gas turbine), Rankine cycle (steam turbine). There are various ways in which the efficiency of both cycle individually can be improved. But when couple together optimization is different thing because improving efficiency of one cycle can adversely affect the efficiency of other cycle and of combined cycle gas turbine. By using thermodynamic analysis, parametric study is done in this work to find the optimum parameter at which efficiency of system is maximum.

A program of numerical code is established using EES (Engineering Equation Solver) software to perform the calculations required for the thermodynamic analysis considering real variation ranges of the main operating parameters such as pressure, temperature, pressure ratio. The effects of theses parameters on the system performances are investigated. Parametric study has been performed using combined first and second law approach to investigate the effects of compressor air inlet temperature and pressure of steam on first and second law efficiency, power-to-heat ratio, exergy destruction in the system components.

Key Words: Combined Cycle Gas Turbine, Exergy, Heat Recovery Steam Generator, Exergy Destruction, Optimization, Efficiency

CHAPTER 1

INTRODUCTION

The drastic change in living standards of people in the last sixty years, has resulted in huge demand for electricity (power). Though there is high growth in power output, but there is always a gap in the demand and supply. Optimization of energy conversion systems becomes more important due to limits of fossil fuels and the environmental impact during their use. To achieve above we need an innovative technology which has higher efficiency than the present one and also environment friendly. Conventional power engines have lower efficiencies. To improve the efficiency, one innovative technology “combined cycle gas turbine” is used nowadays.

1.1 Combined Cycle Gas Turbine Technology

The continuous effort to increase thermal efficiencies of power plants have resulted in innovative modification to existed power plants. One such modification is combined gas-vapor cycle. A combined cycle power plant unites 2 power cycles such that the heat rejected (waste energy) by heat transfer from top cycle can be utilize as the input source for the bottom cycle. This discharged energy is utilized in many ways such as cogeneration, organic Rankine cycle, kalinin cycle etc. Popular combined cycle system is gas-vapor power cycle.

Brayton cycle typically works at high temperatures than Rankine cycle. The steam temperature at turbine entry can be about 600°C for steam turbine but it is over 1450°C for gas turbine. Due to recent advance technologies such as recent innovation in cooling turbine blades and high temperature resistant coating of the blades. To obtain higher thermal efficiency, heat is supplied at high temperature. However, gas turbine cycle has one drawback: the exhaust gas has high temperature usually above 520°C , which is a waste energy for gas turbine power plant. It makes engineering sense to utilize this energy as the input source for steam cycle. The energy is utilized from flue gases to generate steam in HRSG which serve as boiler.

1.2 Combined-Cycle Gas Turbine Features ^[1]

The gas turbine uses high temperature gas at entry and discharges thermal energy at sufficient high temperature which is generally used as the input source for the bottom steam Cycle. Combined cycle systems is used in practical application because of:

1. High first law efficiency
2. Heat rejection from topping cycle at a sufficient high temperature
3. Working fluids are easily available.

Combined cycle systems have attractive features such as,

1. **High Thermal Efficiency** –thermal efficiency of Combined cycle system is higher than any other existing power systems.
2. **Low installation cost**- Combined cycle equipment are available in market. so installation time and cost are low comparatively.
3. **Environmental compatibility**- Innovation in combustion process also means that the harmful effect of exhaust gases can be controlled effectively. Carbon dioxide and nitric oxide discharge can be minimized when plants are fired with methane.
4. **Fuel flexibility**- A wide variety of fuel such as natural gas, methane, distillate oil fuel can be utilized efficiently in combined cycle power plants.
5. **Rapid start-up**- it allows rapid start-up, short shut-down time, and fast and efficient adjustment to varying load condition.
6. **Short construction time**-The top cycle (gas turbine) allows combined cycle power plant to be compact, which minimizes the construction period about two-years.
7. **Less staff and space requirement**- Combined cycle gas turbine plants are developed on a modular basis, which requires comparatively lesser staff.
8. **High Reliability/Availability** - High reliability operation results are possible due to innovative design and development of components of power plants.

1.3 Thermodynamic description

A combined cycle system couples 2 power cycles, gas turbine and steam turbine. It has three main parts:

- a. Brayton cycle (topping cycle)
- b. HRSG (heat exchanger)
- c. Rankine cycle (bottoming cycle)

1.3.1 Brayton cycle (Topping Cycle) [2]: Brayton cycle is used in gas turbine.

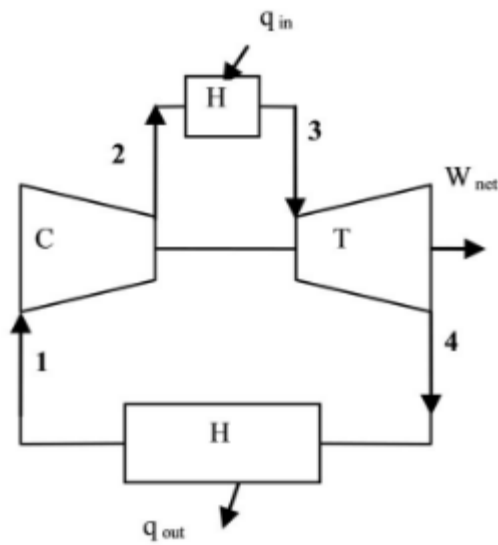

Fig.1.1 A closed cycle gas turbine [2]

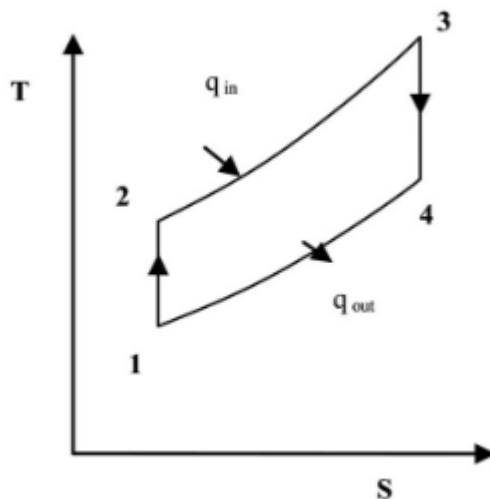

Fig.1.2 T-s diagram of Brayton cycle [2]

The following efforts are made to improve the Brayton cycle efficiency:

1. **Increasing the turbine inlet temperature:** This method is in practice to improve efficiency. But we can only increase temperature to a certain point. The turbine inlet temperature has increased from 500 °C (in 1940's) to 1400 °C. This increase was possible by innovative techniques and new material (high temperature resistant). Steam injection method allowed an increase in TIT by 100 °C.
2. **Increasing the efficiency of component:** The improved efficiency of turbine and compressor resulted in increase in the first law efficiency.
3. **improvise to the basic cycle:** Simple cycle efficiency can be practically increase (doubled) by incorporating modification such as intercooling, regeneration and reheating.

a. Regeneration (Brayton cycle)

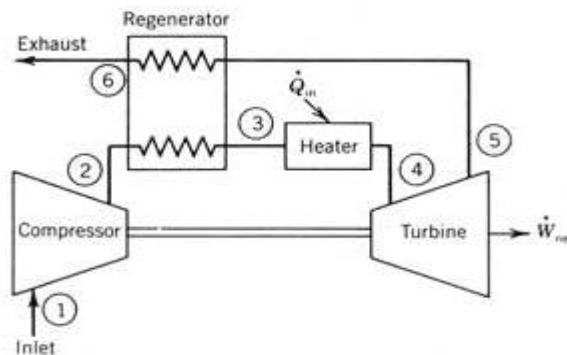

Fig.1.3 open regenerative Brayton cycle [2]

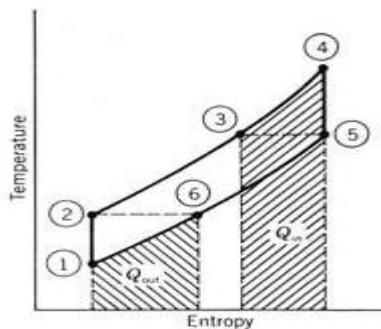

Fig. 1.4 T-s diagram of open regenerative Brayton cycle [2]

In this modification, high temperature flue gases of Brayton cycle are utilized to heat the high pressure air from compressor by transferring heat in a heat exchanger (regenerator). By utilizing energy of exhaust gas which is normally wasted to environment is now utilized to preheat the air.

b. Brayton cycle with intercooling

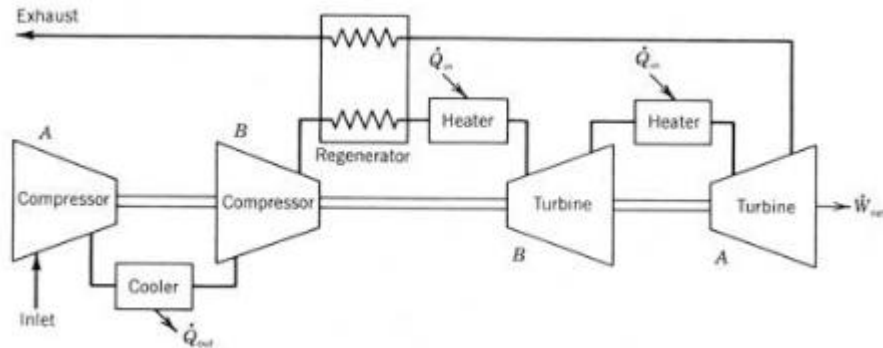

Fig. 1.5 open Brayton cycle with intercooling [2]

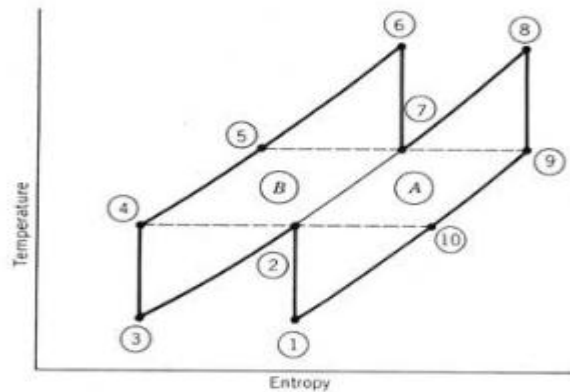

Fig.1.6 T-s diagram of open Brayton cycle with intercooling, reheat and regeneration [2]

The work output of can be improved(increase) by decreasing the work consumed by compressor. By using multistage compressor with intercooler, compressor work can be decreased. work output of gas turbine can be improved (increase) by reheat. This idea is based on simple principal that the work in flow process is proportional to specific volume of gas so this should be minimum as possible in case of compressor and high as in case of turbine.

1.3.2 Rankine Cycle (Bottoming Cycle) [2]:

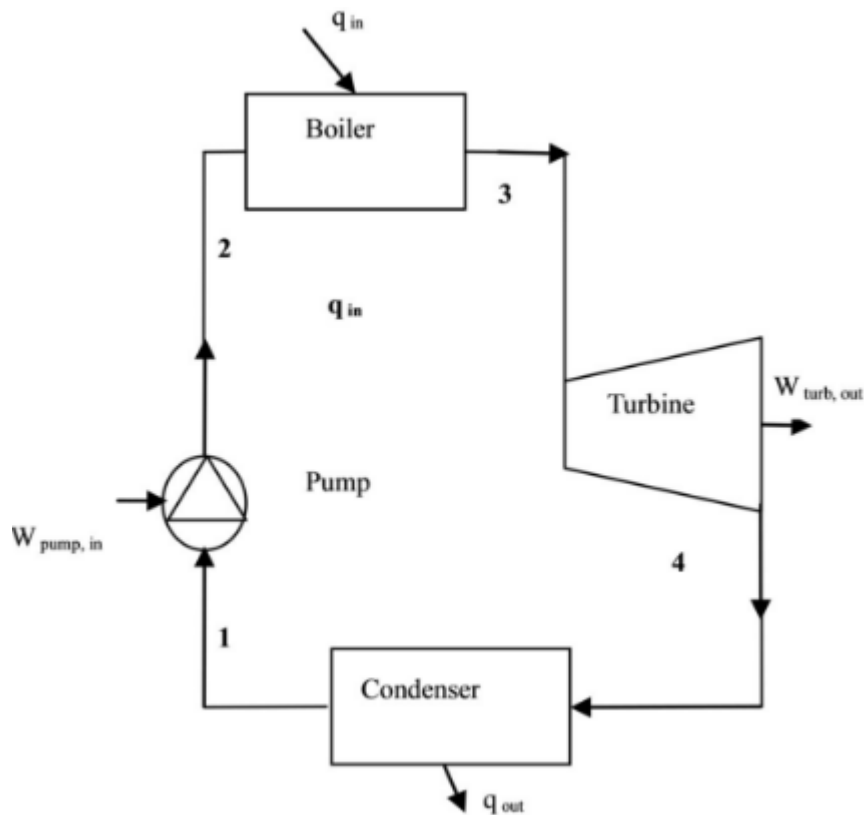

Fig. 1.7 simple Rankine cycle [2]

Steam power plants (Rankine cycle) generate the huge power in India even a minute improvement in plant efficiency can be beneficial (less fuel consumption).

The following methods are used to improve the Rankine cycle efficiency:

1. Lowering the condenser pressure: Before entering the condenser, working fluid is in mix state (steam and water). By lowering the condenser pressure automatically decreases temperature for heat rejection.
2. Superheating the steam (constant pressure) to high temperature: mean temperature of heat addition is increased by this method without increasing the boiler pressure.
3. increasing pressure (in boiler): by increasing the working pressure of steam, average temperature of heat addition can be increased.

4. Regenerative Rankine cycle: ideal regeneration is not practical. A practical process is achieved in plants by extracting working fluid from turbine at various points. By regeneration average temperature of heat addition can be increased.

1.3.3 Heat recovery steam generator (HRSG)

HRSG provides thermodynamic bridge between topping (gas turbine) and bottoming (steam turbine) in combined cycle gas turbine. Exhaust gases of gas turbine carry huge energy. HRSG is used to utilize this energy. HRSG is heat exchanger and used to generate steam.

1.3 Motivation of the Present Research Work

Combined cycle gas turbine systems are used extensively now a day's all around the world. Combined cycle technology is lucrative because of its high efficiency. There are various methods by which the efficiency of gas turbine or steam turbine individually can be increased. But the optimization of combined cycle is different thing. It may be possible that, by increasing the efficiency of any one of turbine may affect the efficiency of combined cycle adversely. So it is necessary to optimize both the cycles in such a way that efficiency of cycle can be improved. By exergy analysis, we can find the points and components where the exergy destruction is high so that effective measures can be taken to increase the efficiency of that component.

1.5 Organization of the Report

Chapter 1 expresses the introduction of combined cycle gas turbine, its history and development. A brief explanation about features and applications of combined cycle gas turbine. Thermodynamics of individual parts. Motivation of research work

Chapter 2 shows literature review section in which various research related to energy and exergy analysis of combined cycle gas system. Also conclusion of the study has been expressed in this chapter.

Chapter 3 describes formulation of combined cycle gas turbine. Also the assumptions made in mathematical formulation, detailed explanation of formulation of system components has been carried out.

Chapter 4 covers results obtained from computer program and discussion of results. Various graphs are plotted. In the first phase, computer program algorithm has been developed for the system. In the second phase, program validation was carried out by supplying various input parameters to the program.

Chapter 5 describes the general conclusions and recommendations for future work of present study.

CHAPTER 2

LITERATURE REVIEW

Combined cycle Gas turbine cogeneration is an extensive area of research, in which several researchers have already made some mark and several others are indulging themselves in this direction. Furthermore, the optimization can be analyzed from a thermodynamic point of view, according to the first and/or second law analysis (Ahmadi and Dincer ^[3], Boyano et al ^[4] and Petrakopoulou et al ^[5]). From the point of view of optimization methodology, there are many types of analyses. In this work, the review will highlight most common methodology: the exergy destruction method. Literature survey for the project is enlisted below.

2.1 Review of Analysis of Gas turbine

2.1.1 Thermodynamic Analysis and Optimization

The gas turbine operating parameters which influence the combined cycle gas turbine performance are; ambient conditions, compressor pressure ratio, and turbine inlet temperature.

One of the factors that affect gas turbine performance is the ambient conditions, mainly ambient temperature, atmospheric pressure, and the relative humidity of air. These parameters affect the generated electric power and the heat-rate during operation. The location of power plant plays a major role on its performance. The atmospheric air, which enters the compressor, becomes hotter after compression and it is directed to a combustion chamber. Several authors reported the effect of ambient temperature: Arora and Rai ^[6], Ibrahim et al ^[7], Ameri and Hejazi ^[8], Boonnasa et al ^[9] and Hosseini et al ^[10].

Arora and Rai ^[6] shows The plant consists of a compressor, combustor, gas turbine, waste heat recovery boiler, steam turbine, and generator(s). The input temperature to a steam turbine is about 540°C and the exhaust can be maintained at the atmospheric pressure, due to design consideration the input temperature is limited and the efficiency of the about 40%. The input temperature of the gas turbine can be as high as 1100°C but the exhaust temperature can be lowered to about 500-600°C, the efficiency of a gas

turbine is about 33%. It can be seen that to obtain higher efficiencies the exhaust of the gas turbine can be used to drive the steam turbine giving efficiency up to 60%.

Ameri and Hejazi [8] observed that the variation in the ambient temperature causes a loss of 20% of the rated capacity of the 170 gas turbine units in Iran. They studied five gas turbines, where the difference between the ambient temperature and the ISO conditions was on average 11.8 °C. They found that for each 1 °C increase in ambient temperature, the power output was decreased by 0.74%, and they suggested cooling the compressor's intake-air temperature to improve the gas turbine cycle efficiency.

Hosseini et al [10] indicated that the gas turbine compressor is designed for constant air volume flow, which makes the electric power output dependent on the ambient temperature through the specific mass flow rate. They added that the increase in the ambient temperature also decreases the compressor's output pressure, which reduces the gas turbine cycle efficiency, while the increase in the air density reduces the gas turbine's heat rate and increases its specific fuel consumption. They stated that for each 1°C increase in the ambient air temperature, the electric power output of the gas turbine decreases by 0.5% to 0.9%, and by 0.27% for a combined cycle.

2.1.1.2 Effect of Compressor Pressure Ratio

The properties of air entering combustion chamber depend upon the compressor pressure ratio studied by: Ibrahim et al [7], Ibrahim and Rahman [11], and Khaliq and Kaushik [12].

Ibrahim and Rahman [11] performed a parametric thermodynamic analysis of a combined cycle gas turbine. They investigated the effect of operating parameters, compression ratio, gas-turbine peak temperature ratio, isentropic compressor and efficiency and air fuel ratio on the overall plant performance. Their results show that the compression ratios, air to fuel ratio as well as the isentropic efficiencies are strongly influenced by the overall thermal efficiency of the combined cycle gas turbine power plant. The overall thermal efficiency increases with compression ratio. However, the variation of overall thermal efficiency is minor at the lower compression ratio while it is very significant at the higher compression ratio for both isentropic compressor and turbine efficiency. The overall efficiencies for combined cycle gas turbine are much higher than the efficiencies of gas

turbine plants. Efficiency quoted range is about 61%. In addition, the overall thermal efficiency increases and total power output decreases linearly with the increase of the compression ratio with constant turbine inlet temperature. The peak overall efficiency occurs at the higher compression ratio with the higher cycle peak temperature ratio as well as higher isentropic compressor and turbine efficiencies.

2.1.1.3 Effect of Turbine Inlet Temperature

The turbine inlet temperature (TIT) plays an important role on the performance of combined cycle. The maximum value of TIT is fixed due to the metallurgical problem of turbine blade cooling. Research in this area was done by:

Sanjay ^[13] observed that the parameter that affects cycle performance most is the turbine inlet temperature (TIT). The TIT should be kept on the higher side, because at lower values, the exergy destruction is higher.

Khaliq and Kaushik ^[12] and **Khaliq** ^[14] reported in their detailed analyses that the exergy destruction in the combustion chamber increases with the cycle temperature ratio, and the second-law efficiency of the primary combustor behaves in reverse from the second-law analysis. Increasing the maximum cycle temperature gives a significant improvement in both efficiency and specific work-output. The study also concludes that the efficiency reduces rapidly with a reduction in the TIT.

2.1.2 Review of Analysis and Optimization of Bottoming Cycle

2.1.2.1 Thermodynamic Analysis and Optimization

The efficiency of steam power plants can be improved by increasing the live steam and reheat-steam parameters, and by introducing high-efficiency, low-loss turbine blade geometries. The first goal, to increase the steam parameters, is primarily achieved by choosing appropriate materials for the components operating under live-steam and reheat-steam conditions while retaining the proven designs. Collaborative European programs have led to the development and qualification of steels with much improved creep properties at temperatures of up to 600 °C, appropriate for the manufacture of key components. At the same time, optimization of the blade profiles and geometries allowed further major improvements in operating efficiency. The achievable

improvements in efficiency is about 0.5% per 10 °C live steam and reheat (RH) temperature increase, and 0.2 % per 10 bar pressure increase. Second important part of the bottoming cycle is the heat recovery steam turbine (HRSG), its design and optimization affects to a large extent influence the efficiency and the cost of the whole plant.

Mohagheghi and Shayegan ^[16] performed the thermodynamic optimization of design variables and heat exchangers layout in a heat recovery steam generator HRSG for combined cycle gas turbine CCGT using a genetic algorithm. Their method was introduced for modelling the steam cycle in advanced combined cycles by organizing the non-linear equations and their simultaneous used solutions with numerical methods. In addition to the optimization of design variables of the recovery boiler, they performed the distribution of heat exchangers among different sections and optimized their layouts in HRSGs. A standard gas turbine was assumed, and then outlet gas stream conditions (mass flow rate, temperature, and chemical composition of gas stream) were considered as the inlet parameters for the recovery boiler model. From the optimization process maximum output power from a steam cycle for different HRSGs was then analyzed.

Bracco and Silvia ^[17] studied a combined cycle power plant with a single level heat recovery steam generator HRSG. They developed a mathematical model to determine the optimal steam pressure values in the HRSG according to different objective functions (in the HRSG for a given gas turbine). Their work reports numerical results for the combined cycle power plant considering four different gas turbines. The optimization approach was focused on the study of the heat transfer between the steam and the exhaust gas in the HRSG, based on an exergetic analysis. They present the comparison among different objective functions that refer to the HRSG specifically or to the whole bottoming cycle. In their mathematical model, they considered the presence of specific constraints for the operating parameters of the power plant, the most important constraints that were considered refer to the steam quality at the turbine outlet, the HRSG outlet exhaust gas temperature and the steam turbine blade height. In their work, a parametric analysis was also performed to evaluate the influence of the

gas temperature at the HRSG inlet and the pinch point temperature difference on the considered objective functions.

Woudstra et al ^[18] performed the thermodynamic evaluation of combined cycle plants with the same gas turbine and different steam bottoming cycles. The evaluation showed that the increasing the number of pressure levels of steam generation will reduce the losses due to heat transfer in the HRSG, but also the exergy loss due to the exhaust of flue gas to the stack. Among the investigated configurations for bottoming cycle, triple pressure reheat was the best option from exergy point of view.

Mansouri et al ^[19] investigated the effect of pressure levels of steam generation at heat recovery steam generator HRSG on the energetic and exergetic efficiency of HRSG, bottoming cycle and combined cycle power plants, as well as the effect of HRSG (heat recovery steam generator) pressure levels on exergy destruction at HRSG and other main components of the bottoming cycle. Their result show that an increase in pressure levels of steam generation at HRSG leads to an increase in the exergy efficiency of HRSG and CCGT increase respectively. In addition, an increase in pressure levels at HRSG decreases the exergy destruction due to heat transfer in HRSG: the exergetic efficiency of HRSG increases with an increase in pressure levels of steam generation and adding reheat to the cycle.

Tyagi and Khan ^[20] studied the effects of gas turbine exhaust temperature, stack temperature and ambient temperature on the overall efficiency of combine cycle power plant keeping the gas turbine efficiency as well as steam turbine efficiency constant. They concluded that the stack temperature should be minimum and gas turbine exhaust temperature should be maximum. Out of these three variables i.e. turbine exhaust temperature, stack temperature and ambient temperature, the dominating factor of increasing the overall efficiency of the combine cycle power plant is the stack temperature.

Valdés et al ^[21] showed a possible way to achieve a thermoeconomic optimization of combined cycle gas turbine power plants. The optimization was done by using a genetic algorithm, tuned by applying it to a single pressure CCGT power plant. Once tuned, the optimization algorithm was used to evaluate more complex plants, with two and three pressure levels in the heat recovery steam generator. The variables considered for the

optimization were the thermodynamic parameters that established the configuration of the HRSG. Two different objective functions were proposed: one minimizes the cost of production per unit of output and the other maximizes the annual cash flow. The results obtained with both functions were compared in order to find the better optimization strategy. The results show that it is possible to find an optimum for each design parameter. This optimum depends on the selected optimization strategy.

Bassily ^[22] presented the effects of varying the inlet temperature of the gas turbine and PP on the performance of a dual pressure reheat combined cycle. He also modeled some feasible techniques to reduce the irreversibility of the HRSG of both cycles, and showed that optimizing or reducing the irreversibility of these cycles could increase their efficiencies by 2–3%. Applying gas reheat increases the generated power and average temperature at which heat is supplied, whereas applying gas recuperation takes advantage of the increased gas temperature at the outlet of the GT to enhance cycle efficiency. For gas-reheat gas-recuperated combined cycles, recuperated heat exchangers fabricated from stainless steel have to be used to withstand these conditions. He compared the optimized results with the regularly designed triple pressure reheat combined cycle.

Boonnasa et al ^[23] studied the performance improvement of an existing combined cycle power plant located in Bangkok that consisted of two gas turbines (110.76MW each), and one 115.14MW steam turbine in ISO conditions. The plant used an absorption chiller to cool one of the two gas turbine's intake-air to 15°C, in addition to having a thermal energy storage tank that stored the sensible heat of the chilled water to meet the varying daily cooling load. Low-pressure steam from a heat recovery steam generator was used to drive the absorption chiller needed to meet a maximum load of 7049.58kW with the help of the thermal heat storage. As a result, the power output of the cooled gas turbine increased by 10%, improving the CCPP total power output by 6.24%. Economically, the study found that due to the low initial investment cost of retrofitting the absorption chiller the internal rate of return was 40%, and the payback period was just 3.81 years. However, the authors also reported a reduction by 2.85% in the steam turbine power output, which was due to powering the absorption chiller directly from the HRSG unit steam that was powering the steam turbine. This reduction in the steam turbine power output could have

been avoided if they had used a boiler that utilized the waste heat energy from the stack after the HRSG unit.

Ahmet Cihan et al^[24] studied the energy and exergy fluxes at the inlet and the exit of the devices in one of the power plant main units and calculate the energy and exergy losses. He found out that highest energy loss occurs at chimney. In addition, energy losses of 18.94 and 18.98% take place at the condenser and the cooling tower, respectively.

2.2 Conclusions of Literature Review

The researchers in the field of combined cycle gas turbine system have already delivered a vast variety of work. However, the possibility of improving the domain of work is still there by combining different methods and methodologies for enhancing the performance of the system. The main conclusions from the Literature review are pointed below-

- Exergy analysis of combined cycle gas turbine system has been performed by various researchers based on first and second law of thermodynamics in which exergy destruction in each and every component of the system has been calculated when it is operated at part and full load conditions. Opportunities are available to analyze different combined cycle gas turbine system viz. simple cycle, combined cycle gas turbine system with alternative bottoming cycle, combined cycle gas turbine system with VARS based on the same input parameters, to analyze the superiority of any particular method in power generation, economy and environmental issues.
- Simulation and dynamic modelling of combined cycle gas turbine-based plants consisting of a gas turbine, heat recovery steam generator and steam turbine has been worked out.
- The concept of reheat has been applied in evaluating thermodynamic performance of combustion gas turbine cogeneration system.

- Individual effect of reheat and intercooling after system modification has been studied by the simulation of the power generation system.
- First and Second law analysis have been performed by various researcher.

2.3 Objectives of the Present Research Work

- To analyze and design combined cycle gas turbine system integrated with reheat and intercooling in topping cycle and reheat in bottom cycle.
- To develop formulation of various components of combined cycle gas turbine system by combined first and second law analysis.
- To develop a computer based design methodology for a modified combined cycle gas turbine system.
- To perform a parametric study for wide range of variables such as compressor air inlet temperature, compressor pressure ratio, turbine inlet temperature, regenerator effectiveness etc. The effect of these parameters on first law efficiency or fuel utilization efficiency, second law efficiency or exergetic efficiency, specific fuel consumption, power to heat ratio etc. has been studied. Exergy destruction in each and every component of gas turbine and steam turbine system has been calculated.

THERMODYNAMIC ANALYSIS AND FORMULATION OF COMBINED CYCLE GAS TURBINE

3.1 Combined Cycle Gas Turbine System Description

A simple combined cycle gas turbine is shown. This consist all basic components. Air at atmospheric condition is passed through compressor where the air is compressed to high pressure. After compressor it enters to combustor where the fuel is supplied and combustion starts. Due to combustion temperature of the mixture increases. Hot gases from combustion chamber is then passed through gas turbine where energy from hot gases is extracted by turbine. Flue gases from gas turbine is then passed through heat exchanger where energy from hot gases is supplied to water. Generated steam is passed through steam turbine where they expand and produce the work output (alternator to generate electricity). After steam turbine steam is passed through condenser where steam loses its heat and gets converted into water.

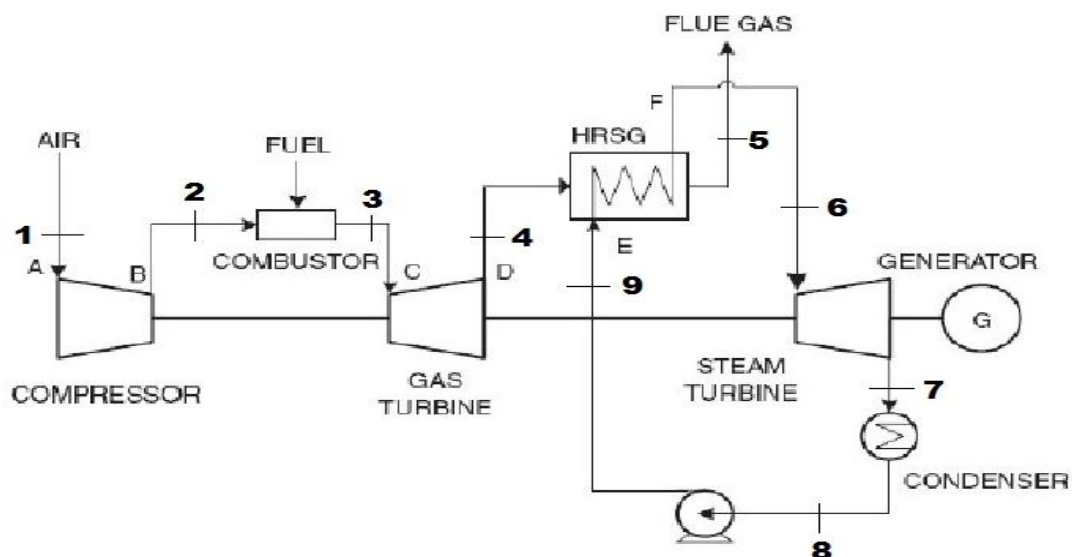

Fig.3.1 Simple combined cycle gas turbine

TABLE 3.1 description of different states corresponding to figure 3.1

Points	Description
1	Entry to compressor
2	Compressor exit
3	gas turbine inlet
4	gas turbine outlet or inlet HRSG
5	HRSG outlet(mixture)
6	HRSG outlet(steam) or steam turbine inlet
7	steam turbine exit
8	condenser outlet or pump inlet
9	pump inlet or inlet HRSG(water)

In this research work, modified combined cycle gas turbine is analyzed which is shown in figure. System consist intercooled and reheat gas turbine with dual pressure HRSG and reheat steam turbine.

Table 3.2 description of points corresponding to figure 3.2

State points	Description
	Gas turbine
1	Compressor(A) entry
2	Compressor(A) exit
3	Compressor(B) inlet or intercooler outlet

4	Compressor(B) outlet or combustion chamber inlet
5	Gas turbine(A) inlet or combustion chamber outlet
6	Gas turbine(A) outlet or reheater inlet
7	Gas turbine(B) inlet or reheater outlet
8	Gas turbine(B) outlet or HRSG inlet
9	HRSG outlet
	Steam turbine
10	Steam turbine(A) inlet

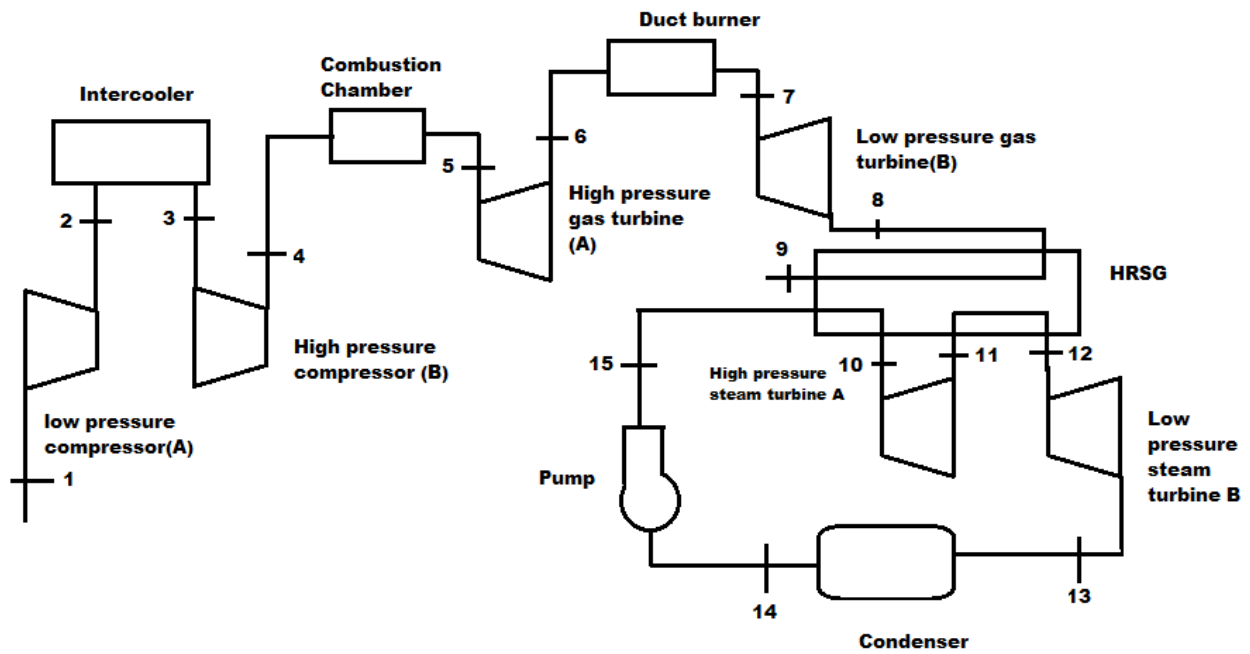

Fig.3.2 combined cycle gas turbine (in present analysis)

11	Steam turbine(A) outlet
----	-------------------------

12	Steam turbine(B) inlet
13	Condenser inlet
14	Pump inlet
15	HRSG inlet

3.2 Mathematical Formulation

The mathematical formulation of present analysis of CCGT is based on following assumptions:

1. Combined cycle gas turbine operates at steady state.
2. Ideal gas laws are applied to the air and the combustion products.
3. The fuel is taken as methane and taken as an ideal gas.
4. The combustion process in the CC (combustion chamber) is complete and N₂ is assumed as inert gas.
5. Pressure drop in various component is neglected.
6. HRSG taken is dual pressure.

The thermodynamic analysis of the proposed combined cycle system has been carried out using equation of mass energy and exergy balance.

For a particular component, a set of governing equations are as follows:

-

Mass rate balance

$$\sum_k \dot{m}_{i,k} = \sum_e \dot{m}_{e,k}$$

Energy rate balance

$$\dot{Q}_{cv,k} - \dot{W}_{cv,k} = \sum_e \dot{m}_{e,k} h_{e,k} + \sum_i \dot{m}_{i,k} h_{i,k}$$

Exergy rate balance

$$\dot{E}_{D,k} = \sum \dot{E}_{q,k} - \dot{W}_{cv,k} + \sum_i \dot{E}_{i,k} - \sum_e \dot{E}_{e,k}$$

3.2.1 Thermodynamic Analysis of Low Pressure Compressor A

Air enters the compressor at point 1. Point 1 represents inlet of compressor A. In compressor air is compressed to point 2. Work done in compressor is given by,

$$\dot{W}_{c,A} = \dot{m}_a(h_2-h_1)$$

Where \dot{m}_a is mass flow rate of air and (h_2-h_1) specific enthalpy difference between states 1 and 2. The value of specific enthalpy h_2 can be evaluated using the compression isentropic efficiency. Solving the expression for compression for compressor isentropic efficiency

$$\eta_c = \frac{h_{2s}-h_1}{h_2-h_1}$$

Where is η_c isentropic efficiency of compressor, h_1 and h_2 are enthalpies of air at state 1 and 2. h_{2s} is the isentropic enthalpy at compressor exit.

Physical Exergy at point 1,

$$\dot{E}_{x,1} = \dot{m}_a * ((h_1-h_0) - T_0 * (s_1-s_0))$$

Physical Exergy at point 2,

$$\dot{E}_{x,2} = \dot{m}_a * ((h_2-h_0) - T_0 * (s_2-s_0))$$

Exergy destruction rate in low pressure compressor can be given by

$$\dot{E}_{D,compressorA} = (\dot{E}_{x,1} - \dot{E}_{x,2}) + \dot{W}_{c,A}$$

Where $\dot{E}_{D,k}$ represents the exergy destruction rate in k component.

3.2.2 Thermodynamic analysis of Intercooler,

Intercooler is type of heat exchanger. Purpose of intercooler is to cool the hot compressed air from low pressure compressor before sending it to high pressure

compressor. So that work consumed by high pressure compressor can be reduced.

Heat is transferred from hot compressed air to cooling water.

Hot compressed air from compressor A is cooled to point 3 in intercooler.

From energy balance,

$$\dot{m}_a(h_2-h_3) = \dot{m}_{w,ic}(h_{w,out}-h_{w,in})$$

where $\dot{m}_{w,ic}$ represents the mass flow rate and $h_{w,out}$ and $h_{w,in}$ represents the specific enthalpy.

Exergy at point 3,

$$\dot{E}_{x,3} = \dot{m}_a((h_3-h_0)-T_0^*(s_3-s_0))$$

Exergy at cooling water inlet,

$$\dot{E}_{x,w,in} = \dot{m}_{w,ic}((h_{w,in}-h_0)-T_0^*(s_{w,in}-s_0))$$

Exergy rate at cooling water outlet,

$$\dot{E}_{x,w,out} = \dot{m}_{w,ic}((h_{w,out}-h_0)-T_0^*(s_{w,out}-s_0))$$

Exergy destruction in intercooler can be given by,

$$\dot{E}_{D,intercooler} = (\dot{E}_{x,1} - \dot{E}_{x,2}) + (\dot{E}_{x,w,in} - \dot{E}_{x,w,out})$$

3.2.3 Thermodynamic analysis of high pressure Compressor B

High pressure compressor is used to increase the overall pressure ratio. Work done in high pressure compressor is given by

$$\dot{W}_{c,B} = \dot{m}_a(h_4-h_3)$$

value of h_4 can be evaluated from isentropic formula. Isentropic efficiency of compressor

$$\eta_c = \frac{h_{4s} - h_3}{h_4 - h_3}$$

Physical exergy at point 4,

$$\dot{E}_{x,4} = \dot{m}_a((h_4-h_0)-T_0^*(s_4-s_0))$$

Exergy destruction in high pressure compressor is given by,

$$\dot{E}_{D,compressorB} = (\dot{E}_{x,3} - \dot{E}_{x,4}) + \dot{W}_{c,B}$$

3.2.4 Thermodynamic analysis of Combustion chamber

Compressed air from compressor B (at point 4) enters into combustion chamber. Fuel is added into chamber and after combustion, temperature and enthalpy of air-fuel mixture rises.

From energy balance,

$$\dot{m}_a * h_4 + \dot{m}_{fcc} * LHV * \eta_{cc} = (\dot{m}_a + \dot{m}_{fcc}) * h_5$$

where \dot{m}_{fcc} represents the mass flow rate of fuel in cc, LHV represents the lower heating value of fuel and η_{cc} represents the efficiency of combustion chamber.

Exergy at point 5,

$$\dot{E}_{x,5} = (\dot{m}_a + \dot{m}_{fcc}) * ((h_5 - h_0) - T_0 * (s_5 - s_0))$$

For gaseous fuel with composition C_xH_y , the following correlation is used for calculating exergy of fuel,

$$\zeta = \frac{\dot{E}_{x,f}}{LHV}$$

and

$$\zeta = 1.033 + 0.0169 \frac{y}{x} - \frac{0.0698}{x}$$

where $\dot{E}_{x,f}$ represent the exergy of fuel.

Exergy destruction is given by,

$$\dot{E}_{D, \text{combustion chamber}} = (\dot{E}_{x,4} - \dot{E}_{x,5}) + \dot{E}_{x,fcc}$$

3.2.5 Thermodynamic analysis of high pressure Gas Turbine A,

Hot compressed air from combustion chamber is expanded in high pressure gas turbine. Turbine extracts the energy from hot gases and converts it to mechanical energy.

Work done by gas turbine is given by,

$$\dot{W}_{GT,A} = (\dot{m}_a + \dot{m}_{fcc}) * (h_5 - h_6)$$

Isentropic efficiency of turbine,

$$\eta_T = \frac{h_5 - h_6}{h_5 - h_{6s}}$$

Physical exergy at point 6,

$$\dot{E}_{x,6} = (\dot{m}_{a+} \dot{m}_{fcc}) * ((h_6 - h_0) - T_0 * (s_6 - s_0))$$

Exergy destruction in high pressure gas turbine is given by,

$$\dot{E}_{D,gasturbineA} = (\dot{E}_{x,5} - \dot{E}_{x,6}) - \dot{W}_{GT,A}$$

3.2.6 Thermodynamic analysis of Duct Burner

After expansion from high pressure gas turbine A, low temperature combustion gases enter into reheater (duct burner) where fuel is added into chamber and after combustion hot combustion gases exit at point 7.

From energy balance,

$$(\dot{m}_{a+} \dot{m}_{fcc}) * h_6 + \dot{m}_{fdb} * LHV * \eta_{rh} = (\dot{m}_{a+} \dot{m}_{fcc} + \dot{m}_{fdb}) * h_7$$

Where \dot{m}_{fdb} represents the mass flow rate in duct burner.

Physical exergy at point 7,

$$\dot{E}_{x,7} = (\dot{m}_{a+} \dot{m}_{fcc} + \dot{m}_{fdb}) * ((h_7 - h_0) - T_0 * (s_7 - s_0))$$

Exergy destruction in duct burner is given by,

$$\dot{E}_{D,ductburner} = (\dot{E}_{x,6} - \dot{E}_{x,7}) + \dot{E}_{x,fdb}$$

3.2.7 Thermodynamic analysis of low pressure Gas turbine B,

After duct burner (point 7), hot flue gases expand through gas turbine B where energy is extracted by turbine and flue gases exit at point 8.

Work done by gas turbine is given by:

$$\dot{W}_{GT,B} = (\dot{m}_{a+} \dot{m}_{fcc} + \dot{m}_{frh}) * (h_7 - h_8)$$

Isentropic efficiency of turbine,

$$\eta_T = \frac{h_7 - h_8}{h_7 - h_{8s}}$$

Physical Exergy at point 8,

$$\dot{E}_{x,8} = (\dot{m}_{a+} \dot{m}_{fcc} + \dot{m}_{frh}) * ((h_8 - h_0) - T_0 * (s_8 - s_0))$$

Where \dot{m}_{frh} represent the mass flow rate of fuel in duct burner.

Exergy destruction in low pressure gas turbine B,

$$\dot{E}_{D,gasturbineB} = (\dot{E}_{x,7} - \dot{E}_{x,8}) - \dot{W}_{GT,B}$$

3.2.8 Heat Recovery Steam Generator

From energy balance,

$$(\dot{m}_{a+} + \dot{m}_{fcc} + \dot{m}_{frh}) * (h_8 - h_9) = \dot{m}_v * (h_{10} - h_{15} + h_{12} - h_{11})$$

Where \dot{m}_v represents the mass flow rate of steam.

Physical Exergy at point 9,

$$\dot{E}_{x,9} = (\dot{m}_{a+} + \dot{m}_{fcc} + \dot{m}_{frh}) * ((h_9 - h_0) - T_0 * (s_9 - s_0))$$

Exergy destruction in heat recovery steam generator is given by,

$$\dot{E}_{D,HRSG} = \dot{E}_{x,8} + \dot{E}_{x,15} + \dot{E}_{x,11} - \dot{E}_{x,9} - \dot{E}_{x,10} - \dot{E}_{x,12}$$

3.2.9 Thermodynamic analysis of high pressure Steam Turbine A

High pressure and pressure steam is expanded through high pressure steam turbine A where turbine extracts the energy from steam and produces mechanical work. Work done by turbine is given by,

$$\dot{W}_{ST,A} = (\dot{m}_v) * (h_{10} - h_{11})$$

Isentropic efficiency of turbine is given by,

$$\eta_T = \frac{h_{10} - h_{11}}{h_{10} - h_{11s}}$$

Physical exergy at point 10,

$$\dot{E}_{x,10} = (\dot{m}_v) * ((h_{10} - h_0) - T_0 * (s_{10} - s_0))$$

Physical exergy at point 11,

$$\dot{E}_{x,11} = (\dot{m}_v) * ((h_{11} - h_0) - T_0 * (s_{11} - s_0))$$

Exergy destruction in high pressure turbine is given by,

$$\dot{E}_{D,steamturbineA} = (\dot{E}_{x,10} - \dot{E}_{x,11}) - \dot{W}_{ST,A}$$

3.2.10 Thermodynamic analysis of low pressure Steam Turbine B

Low temperature steam from exhaust of high pressure steam turbine is reheated in heat recovery steam generator to high temperature. This high temperature steam is expanded in low pressure steam turbine. Work done in steam turbine is given by,

$$\dot{W}_{ST,B} = (\dot{m}_v) * (h_{12} - h_{13})$$

Isentropic efficiency of turbine is given by,

$$\eta_T = \frac{h_{12} - h_{13}}{h_{12} - h_{13s}}$$

Physical exergy at point 12,

$$\dot{E}_{x,12} = (\dot{m}_v) * ((h_{12} - h_0) - T_0 * (s_{12} - s_0))$$

Physical exergy at point 13,

$$\dot{E}_{x,13} = (\dot{m}_v) * ((h_{13} - h_0) - T_0 * (s_{13} - s_0))$$

Exergy destruction in low pressure steam turbine,

$$\dot{E}_{D, \text{steam turbine B}} = (\dot{E}_{x,12} - \dot{E}_{x,13}) - \dot{W}_{ST,B}$$

3.2.11 Thermodynamic analysis of Condenser

Condenser is a type of heat exchanger. After expansion, steam is passed through condenser where heat is transferred from steam to cooling water which flows around condenser and steam is condensed to water.

From energy balance.

$$(\dot{m}_v) * (h_{13} - h_{14}) = \dot{m}_{w, \text{cond}} * (h_{w, \text{out}} - h_{w, \text{in}})$$

Where $\dot{m}_{w, \text{cond}}$ represents the mass flow rate of cooling water around condenser.

Physical exergy at point 14,

$$\dot{E}_{x,14} = (\dot{m}_v) * ((h_{14} - h_0) - T_0 * (s_{14} - s_0))$$

Physical exergy at point of cooling water in,

$$\dot{E}_{x,w, \text{in}} = \dot{m}_{w, \text{cond}} * ((h_{w, \text{in}} - h_0) - T_0 * (s_{w, \text{in}} - s_0))$$

Physical exergy at point cooling water out,

$$\dot{E}_{x,w, \text{out}} = \dot{m}_{w, \text{cond}} * ((h_{w, \text{out}} - h_0) - T_0 * (s_{w, \text{out}} - s_0))$$

Exergy destruction in condenser,

$$\dot{E}_{D, \text{condenser}} = (\dot{E}_{x,13} - \dot{E}_{x,14}) + (\dot{E}_{x,w, \text{in}} - \dot{E}_{x,w, \text{out}})$$

3.2.12 Thermodynamic analysis of pump

Pump is used to pump condensed water from condenser to operating pressure. Work done in pump is given by,

$$\dot{W}_P = \dot{m}_v * (h_{15} - h_{14})$$

value of h_{15} can be evaluated from isentropic formula.

Isentropic efficiency of pump

$$\eta_p = \frac{h_{15s} - h_{14}}{h_{15} - h_{14}}$$

Physical exergy at point 15,

$$\dot{E}_{x,15} = (\dot{m}_v) * ((h_{15} - h_0) - T_0 * (s_{15} - s_0))$$

Exergy destruction in pump is given by,

$$\dot{E}_{D,pump} = (\dot{E}_{x,14} - \dot{E}_{x,15}) + \dot{W}_P$$

Net work output of combined cycle gas turbine is given by,

$$\dot{W}_{net} = \dot{W}_{GT,A} + \dot{W}_{GT,B} + \dot{W}_{ST,A} + \dot{W}_{ST,B} - \dot{W}_{C,A} - \dot{W}_{C,B} - \dot{W}_P$$

3.3 Performance Parameters

The relevant parameters required for the thermodynamic analysis of COMBINED CYCLE gas turbine cogeneration system are summarized below:

First law efficiency: By definition,

$$\eta_I = \frac{\dot{W}_{net}}{\text{(Total Heat Supplied By Fuel)}}$$

Second law efficiency: It is also called exergetic efficiency (effectiveness or rational efficiency). By definition,

$$\eta_{II} = \frac{\dot{W}_{net}}{\text{(Total Exergy Supplied By Fuel)}}$$

SIMULATION STUDIES AND RESULTS

This chapter describes the formulation of combined cycle gas turbine system. Based upon this formulation, solution methodology, model validation, comparison of results and discussions are given below.

4.1 Solution Methodology

The structure of computer program consists of different equations written in EES (Engineering Equation Solver) software to calculate wide range of output parameters required. These parameters have been used to perform energy and exergy analysis of different components of the system. Different properties (fuel, air, combustion products etc.) are inbuilt in EES software which has been used directly in calculation. One of the most interesting features of EES is that it can solve the problem iteratively in less time and the solution of required output parameters appears in the solution window. The main condition of solving any problem is that the number of equations should be equal to number of unknowns.

4.2 Model Validation

Initially, the computer program developed for cogeneration system has been validated with the system given in ref. The various components of the combined cycle gas turbine system are shown. In this system, there is no modification of in any of both cycle.

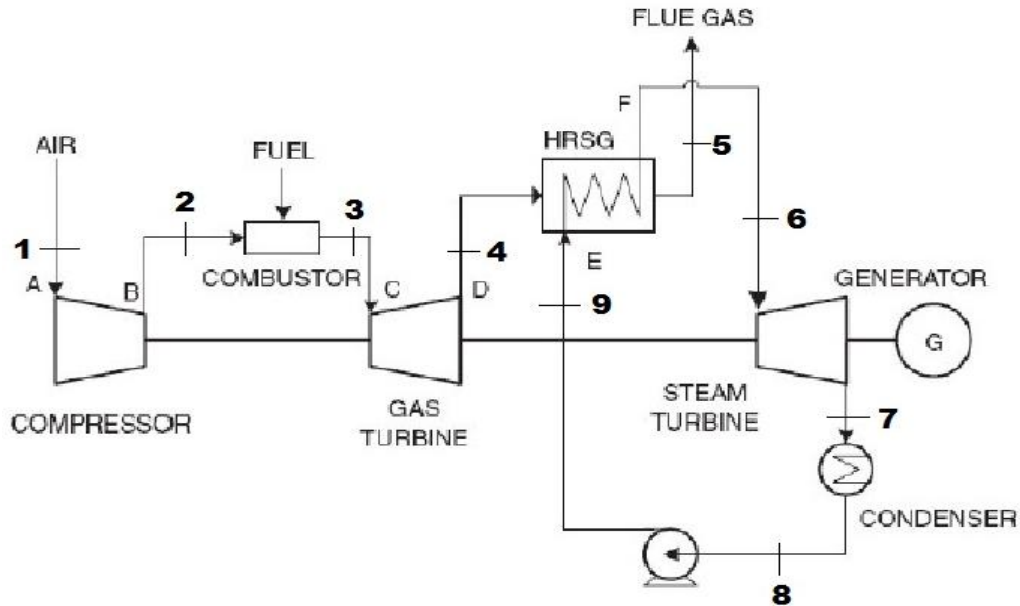

Fig. 4.1 Simple Combined Cycle Gas Turbine System

Table 4.1 Input data for analysis of simple combined cycle gas turbine system

Air inlet pressure to compressor (P_1), in bar	1.013
Air inlet temperature to compressor, (T_1) in K	300
Pressure ratio of compressor (r_p)	12:1
Isentropic efficiency of compressor (η_{sc}), in %	0.85
Turbine inlet temperature (TIT) or maximum cycle temperature (T_3), in K	1400
Isentropic efficiency of Turbine (η_{st}), in %	0.85
Exhaust pressure of combustion prod after HRSG (P_5), in bar	1.013
Mass flow rate of steam generated in HRSG (m_s) in kg/s	14
Pressure of steam generation (P_9) in bar	60
Pressure of condensate water at inlet of HRSG (P_9), in bar	60
Lower heating value of fuel (LHV), in kJ/kg	47140

Net power output of the plant (W_{net}), in MW	45
Injection pressure of fuel (methane) (P_f), in bar	14
Injection temperature of fuel (methane) (T_f), in K	300
Steam turbine inlet temperature in K	673
Condenser pressure in kPa	8

Table 4.2 Results obtained from analysis of simple combined cycle system

Compressor work in kJ	37706
Gas turbine work in kJ	65908
Steam turbine work in kJ	16930
Pump work in kJ	132.8
Mass flow rate of air(in kg/s)	103.5
Mass flow rate of steam(in kg/s)	17.61
Mass flow rate of fuel(in kg/s)	1.898
First law efficiency in(%)	50.28

To improve the efficiency of above system, some modifications are done, reheat and intercooling are introduced in topping cycle while reheat also introduced in bottom cycle. Above system is shown in figure.

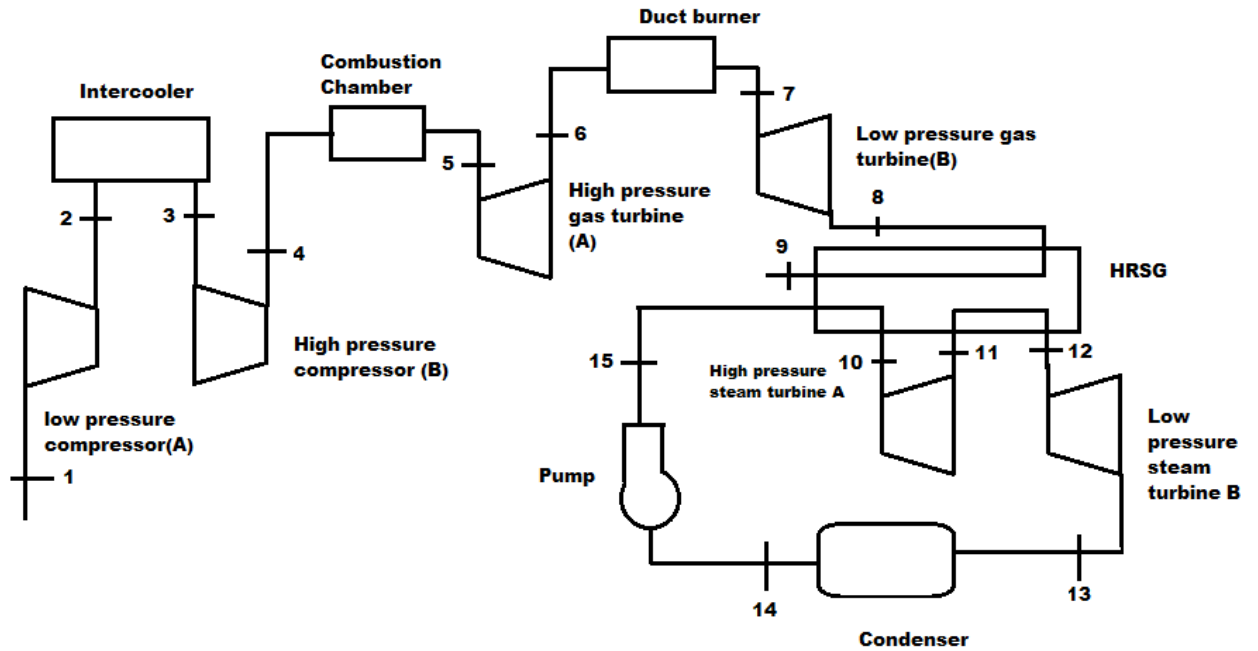

Fig. 4.2 modified combined cycle system

Initially a computer is developed to get starting result and later on parametric study is done to optimize the overall system

Table 4.3 Input data for analysis of modified combined cycle system

Air temperature at compressor(A) inlet in K	300
Pressure at compressor A inlet in bar	1.03
Pressure ratio in compressor (A)	8:1
Overall pressure ratio	60:1
Gas turbine inlet temperature in K (TIT)	1400
Gas reheat temperature in K	1400
Pressure ratio in gas turbine A	10:1

Pressure at exit of HRSG	1.03
Temperature of gas at exit of HRSG in K	370
Pressure of steam generated in HRSG in bar	120
Temperature of steam at steam turbine inlet in K	700
Steam reheat temperature in K	700
Pressure ratio in steam turbine A	10:1
Condenser pressure in bar	0.08

Table 4.4 results obtained from modified combined cycle system

First law efficiency in %	55.51
Second law efficiency in %	52.85
Mass flow rate of air in kg/s	46.85
Mass flow rate of steam in kg/s	8.37
Mass flow rate of fuel in combustion chamber in kg/s	1.005

Table 4.5 Exergy analysis of different components of modified combined cycle system

Component	Work in kJ/s	Exergy Destruction In kJ/s	% exergy destruction	Second law efficiency in %
Compressor A	13720	1202	2.763	91.24
Compressor B	14421	1205	2.771	91.65
Gas turbine A	33979	639.4	1.47	98.15
Gas turbine B	28243	342.2	0.6878	98.8
Steam turbine A	3728	425.2	0.97	89.76
Steam turbine B	7296	1219	2.84	85.68
Pump	105.3	0.64	0.01	95.27
Intercooler		4055	9.325	98.2
Combustion chamber		18302	42.09	77.15
Duct burner		11650	26.79	81.96
HRSG		2889	6.644	88.21
Condenser		934.8	2.15	98.5
Exhaust gas		407.8	0.9378	

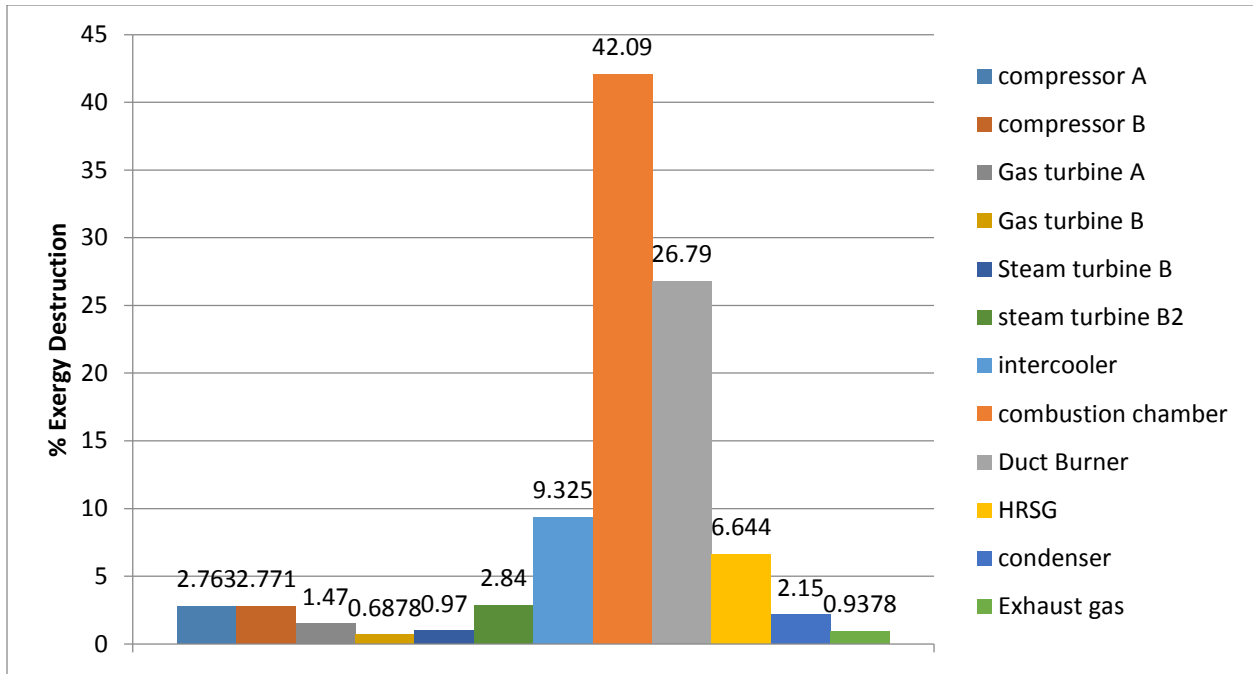

Fig. 4.3 % Exergy destruction of total Exergy destruction in different components

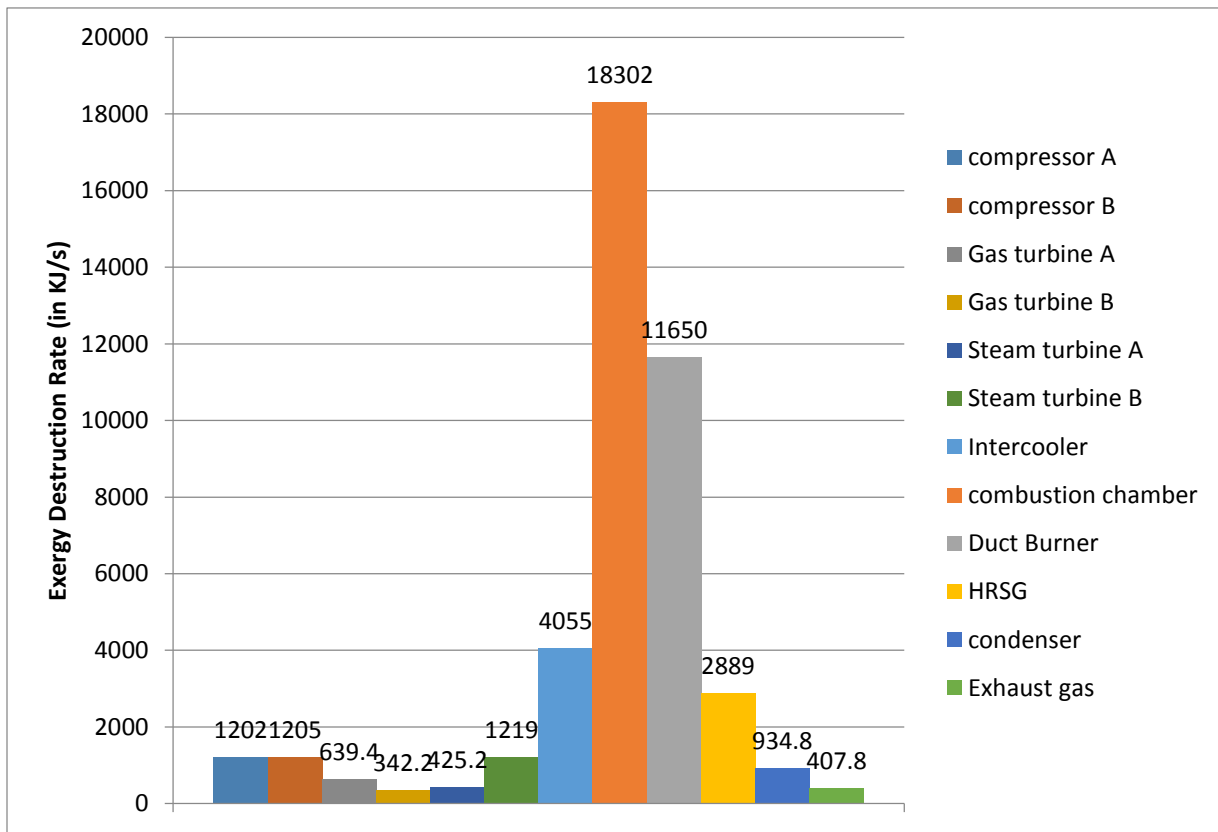

Fig 4.4 Exergy destruction rate in different components

4.3 Parametric Studies

Parametric studies are done to optimize the system in this case combined cycle gas turbine. Main purpose of this work is to improve thermal efficiency of combined cycle gas turbine system. The effects of various parameters on the thermal efficiency are described below,

4.3.1 Effect of overall pressure ratio in gas turbine (r_p) on first and second law efficiency

Figure 4.5 and 4.6 illustrates the efficiency of combined cycle gas turbine power plant as the function of overall pressure ratio at various gas turbine inlet temperature (TIT). Pressure ratio is varied from 60 to 100 in step of 5 while TIT is varied from 1600 K to 1800K. It is observed that as the overall pressure ratio increases both first and second law efficiency increase. But for particular value of pressure ratio both first and second law efficiency increases with increase in TIT. because at higher pressure ratio work done by gas turbine increases more rapidly than work consumed by compressor.

4.3.2 Effect of pressure ratio (r_{p1}) of low pressure compressor A on first and second law efficiency

Figure 4.7 and 4.8 shows the effect of pressure ratio of low pressure compressor on the first and second law efficiency at various gas turbine inlet temperature(TIT). Pressure ratio is varied from 2 to 50 while TIT is varied from 1600 K to 1800. It is observed from the figures that at constant TIT as pressure ratio increases both first and second law efficiency first increase attains maximum value and then decrease. This is because at high pressure ratio, work consumed by low pressure compressor increases rapidly while work done by gas turbine is constant. Both first and second law efficiency increases with the increase in TIT at constant pressure ratio.

4.3.3 Effect of pressure ratio (r_{p3}) of high pressure Gas Turbine A on first and second law efficiency

Figures 4.9 and 4.10 illustrate the effect of pressure ratio of high pressure gas turbine on the first and second law efficiency at various gas turbine inlet temperature (TIT).

Pressure ratio is varied from 2 to 50 while TIT is varied from 1600 K to 1800. It is observed from the figures that at constant TIT as pressure ratio increases both first and second law efficiency first increase then attain maximum value and then decrease. This is because as pressure ratio in high pressure gas turbine increases the temperature of exhaust gas decreases and more fuel is required in duct burner to raise the temperature of gas. Though work done by high pressure gas turbine increases but energy consumption is more and work done in low pressure gas turbine also decreases hence the efficiencies decrease.

4.3.4 Effect of Gas Turbine Inlet Temperature (TIT) on First and Second Law Efficiency

Figures 4.11 and 4.12 describe the effect of gas turbine inlet temperature (TIT) on the first and second law efficiency at various overall gas turbine pressure ratio. TIT is varied from 1500 K to 1800 K in step of 10 while pressure ratio is varied from 60 to 100. Both first and second law efficiency increase with the increase in TIT at constant pressure ratio. As the TIT increases, more fuel is required to raise the temperature of the compressed air but the work done by both high and low pressure gas turbines also increase and at the same time temperature of exhaust gases also increase so more steam is generated and work done by steam turbines also increase. At constant TIT, both first and second law efficiency increase with increase in overall pressure ratio.

4.3.5 Effect of Steam Turbine Pressure on First and second Law Efficiency

Figures 4.13 and 4.14 demonstrate the effect of steam turbine pressure on the first and second law efficiency at various gas turbine inlet temperature(TIT). Steam turbine pressure is varied from 120 bar to 180 bar in steps of 10 while TIT is varied from 1600 K to 1800 K. It is observed from figures that both first and second law efficiency increase with increase in steam turbine pressure at constant TIT. As the steam pressure increases, work done by both high pressure and low pressure steam turbine also increases but this increase, fuel consumption also decreases and at the same time work done by both high and low pressure gas turbines also decreases hence this has very little effect on the first

and second law efficiency. At constant steam pressure, both first and second law efficiency increase with increase in TIT.

4.3.6 Effect of Pressure Ratio of high pressure Steam Turbine on First and Second Law Efficiency

Figures 4.15 and 4.16 describe the effect of pressure ratio of high pressure steam turbine on first and second law efficiency at various gas turbine inlet (TIT) temperatures. Pressure ratio is varied from 2 to 50 in step of 2 while TIT is varied from 1600 K to 1800 K. It is observed from the figure that, as the pressure ratio increases, both first and second law efficiency first increase then attains maximum value and decrease. This is because at high pressure ratio work done by high pressure steam turbine increases but work done by low pressure steam turbine decreases rapidly and fuel consumption also increases. At constant pressure ratio both first and second law efficiency increase with increase in TIT.

4.3.7 Effect of steam turbine inlet temperature on First and second Law Efficiency

Figures 4.17 and 4.18 describe effect of steam turbine inlet temperature on first and second law efficiency of combined cycle gas turbine at various gas turbine inlet (TIT) temperature. Steam turbine inlet temperature is varied from 600 K to 800 K in step of 10 units while TIT is varied from 1600 K to 1800K. Both first and second law efficiency increase with the increase in steam turbine inlet temperature. This is because, work done by both high pressure and low pressure gas turbines increases and fuel consumption decreases with increases in steam turbine inlet temperature. At constant steam turbine inlet temperature both first and second law efficiency increase with increase in TIT

4.3.8 Effect of Temperature of Air at low pressure Compressor Inlet on First and second Law Efficiency

Figures 4.15 and 4.16 tell the effect of inlet air temperature on first and second law efficiency of combined cycle gas turbine at various gas turbine inlet temperatures. Temperature of inlet air is varied from 285 K to 305 K while TIT is varied from 1600 K to 1800 K. From figures it can be seen that both first and second law efficiency decrease with increase in inlet air temperature at constant TIT. As inlet air temperature increases

work done by both high and low pressure gas turbine increases but work consumed in both high pressure and low pressure compressor increases rapidly and fuel consumption also increases. at constant inlet air temperature both first and second law efficiency increase with increase in TIT.

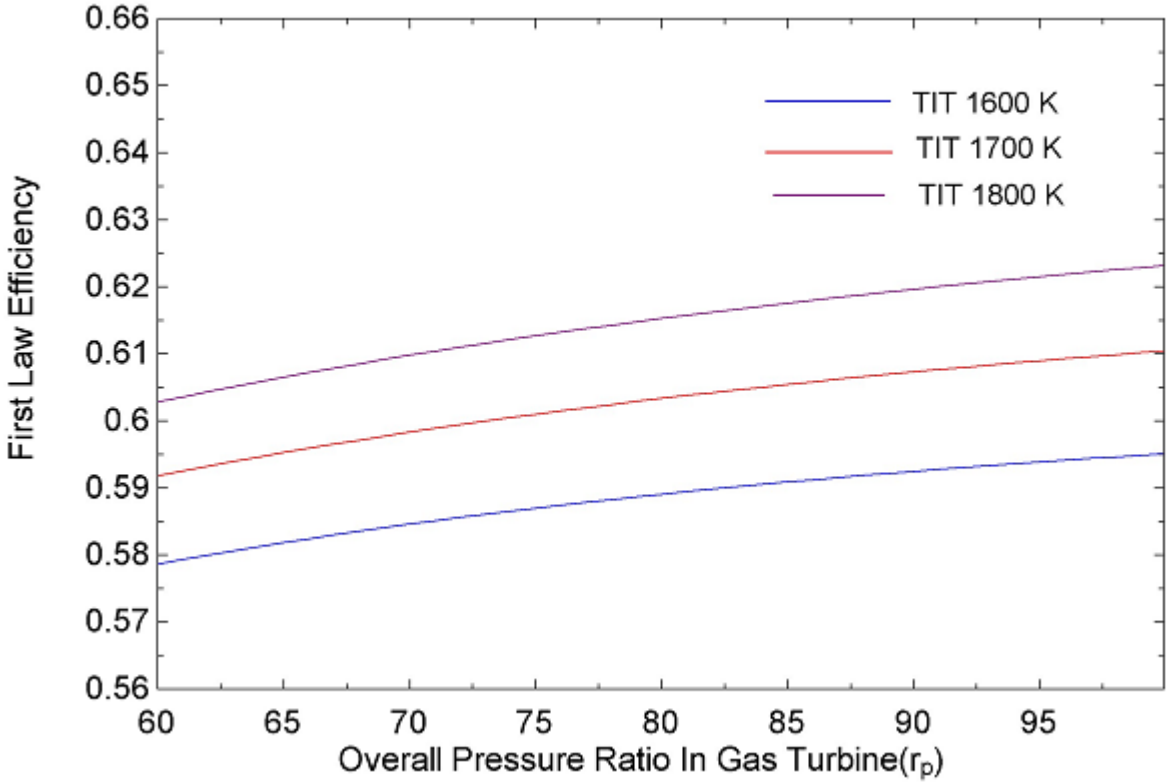

Fig 4.5 Variation of first law efficiency with overall pressure ratio in gas turbine

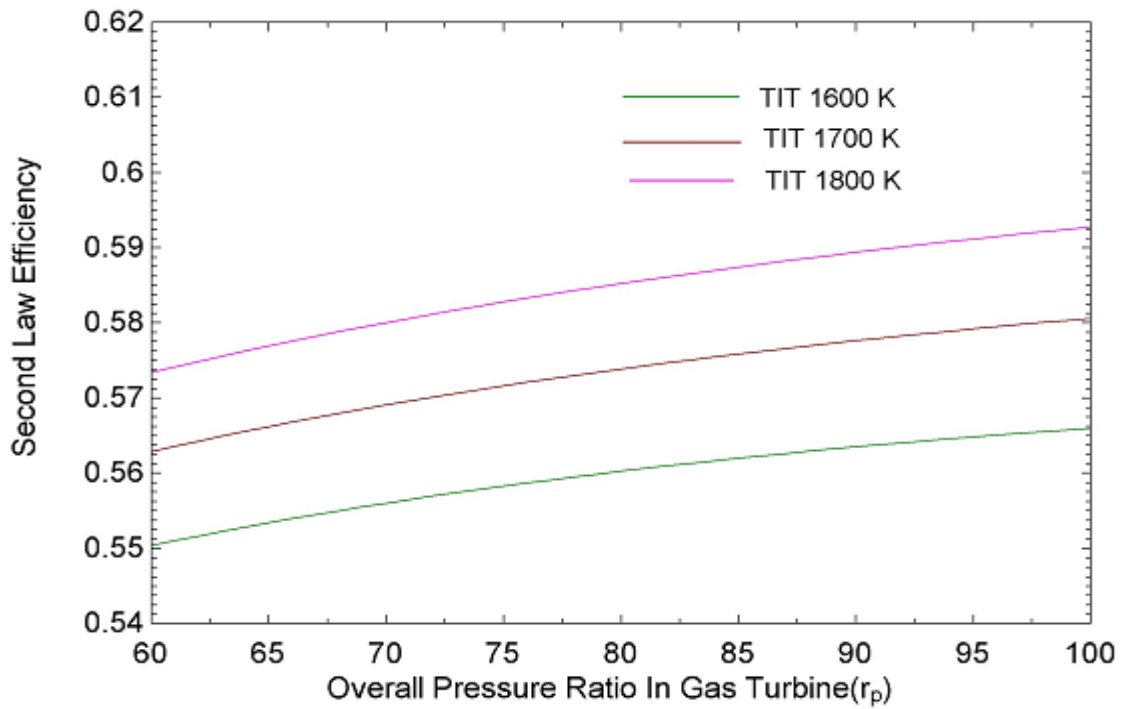

Fig 4.6 Variation of second law efficiency with overall pressure ratio in gas turbine

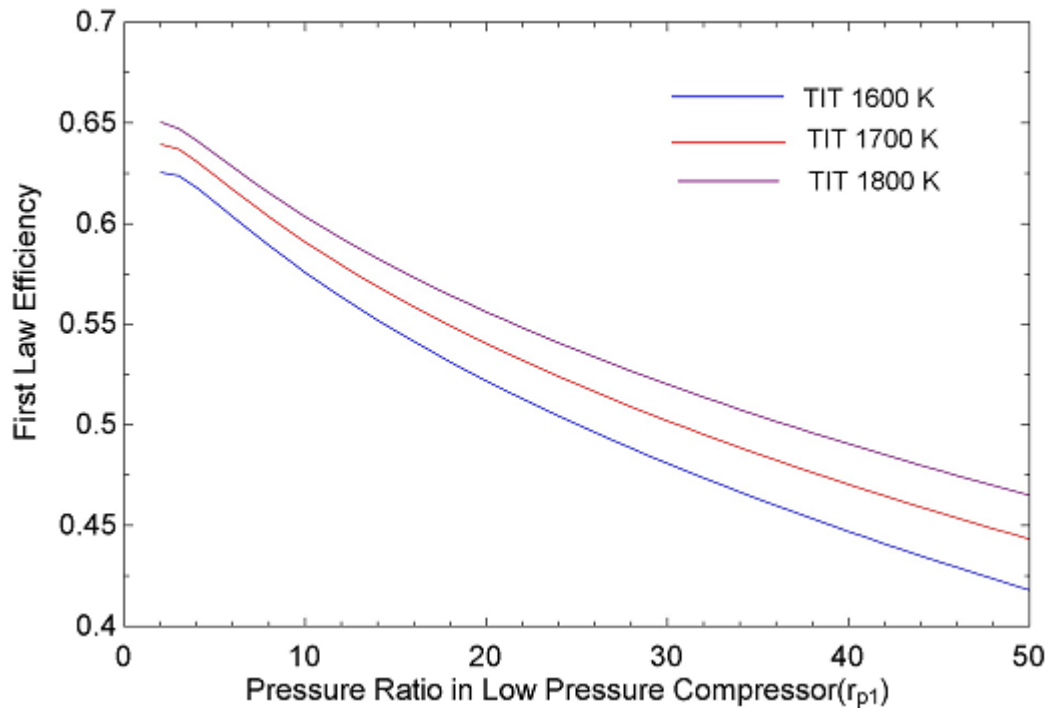

Fig 4.7 effect of pressure ratio in low pressure compressor on first law efficiency

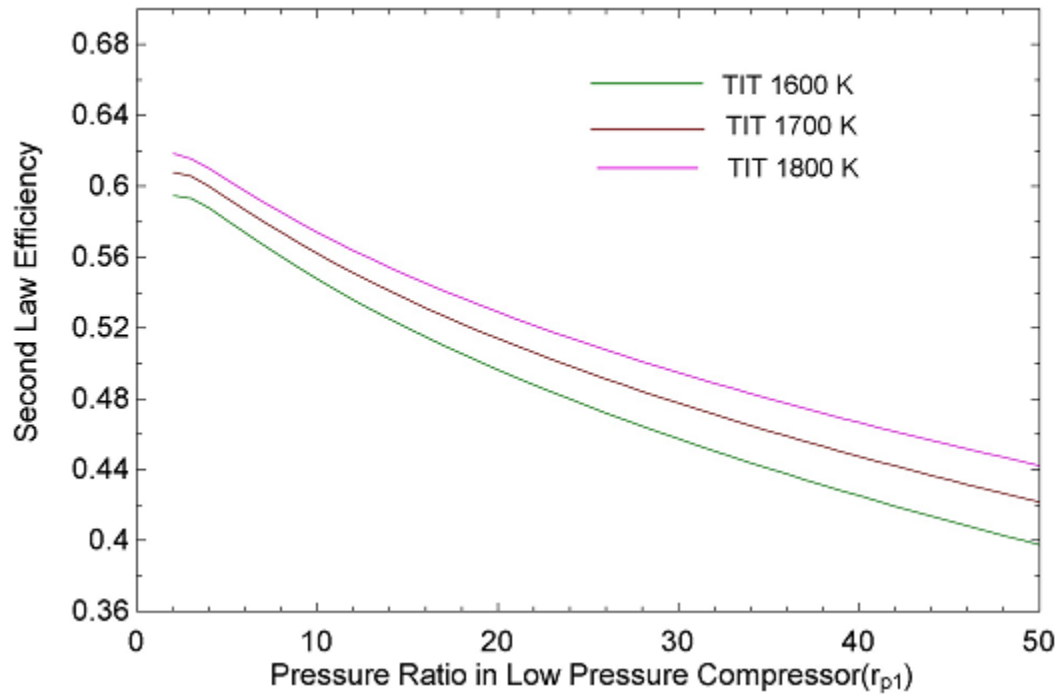

Fig 4.8 effect of pressure ratio in low pressure compressor on second law efficiency

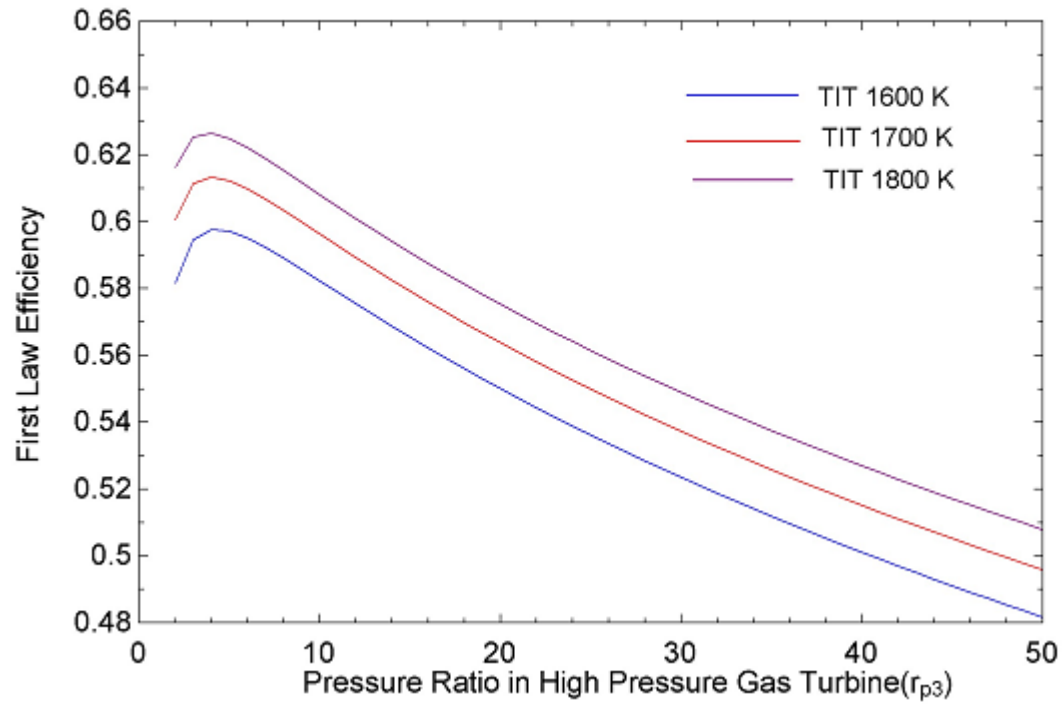

Fig 4.9 effect of pressure ratio in high pressure gas turbine on first law efficiency

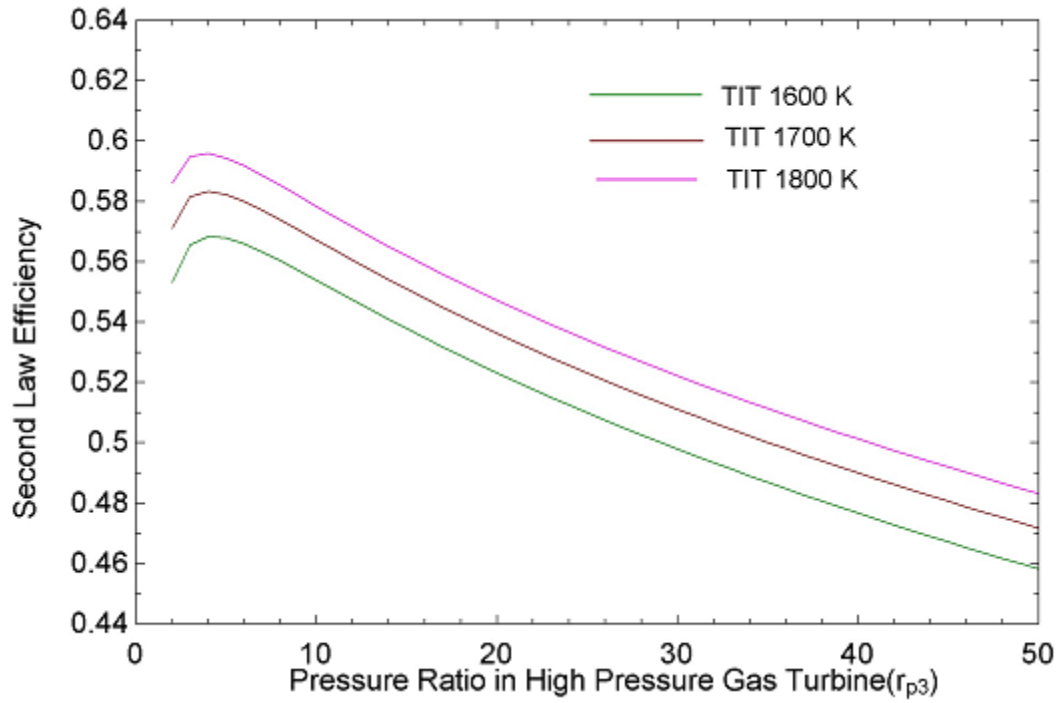

Fig 4.10 effect of pressure ratio in high pressure gas turbine on second law efficiency

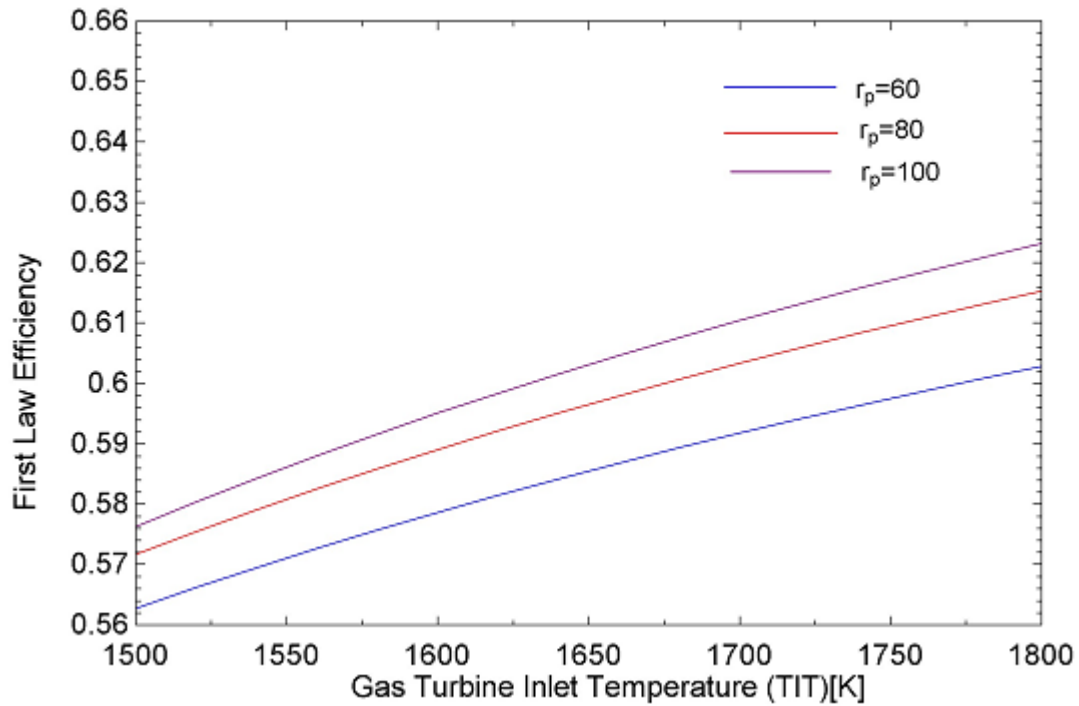

Fig 4.11 effect of gas turbine inlet temperature on first law efficiency

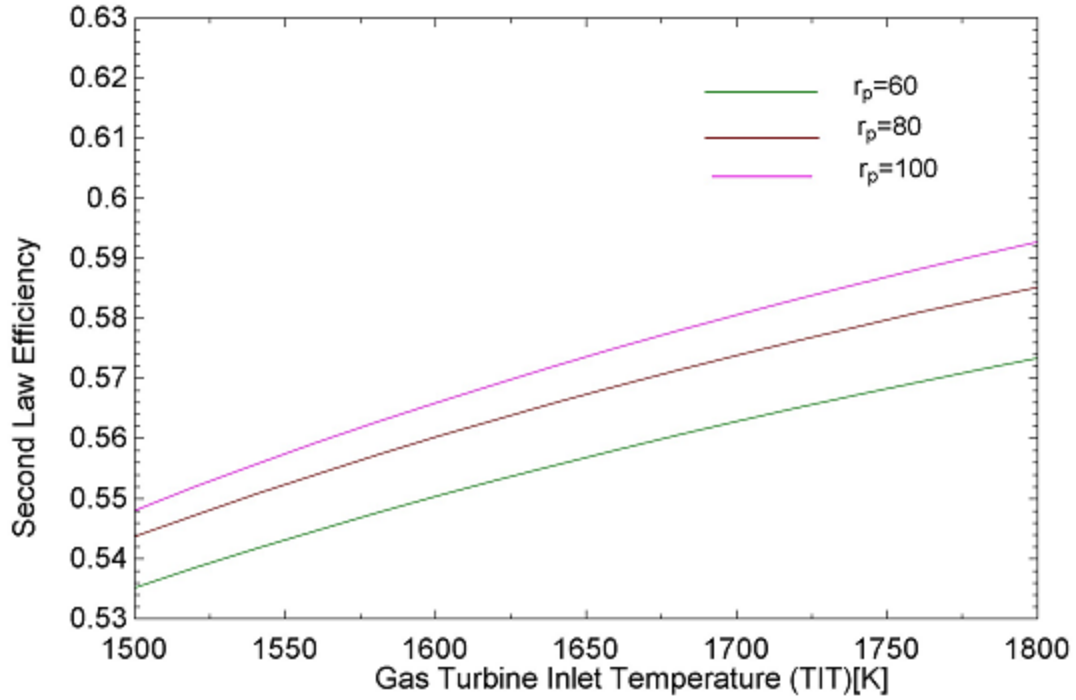

Fig 4.12 effect of gas turbine inlet temperature on second law efficiency

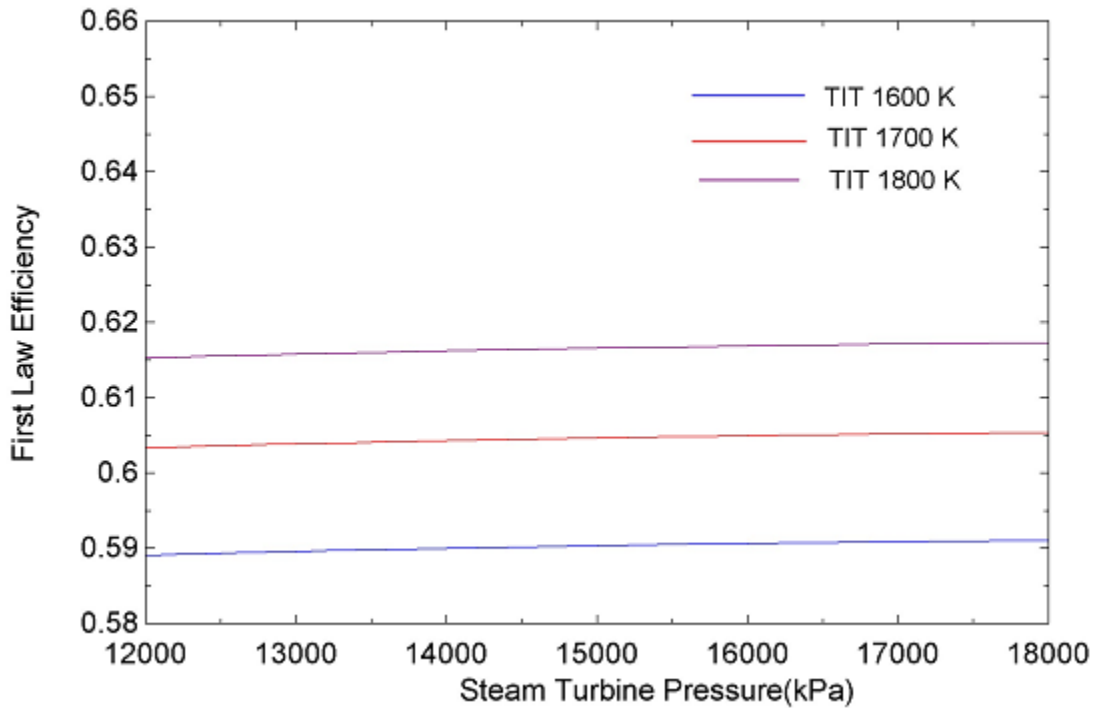

Fig 4.13 effect of steam turbine pressure on first law efficiency

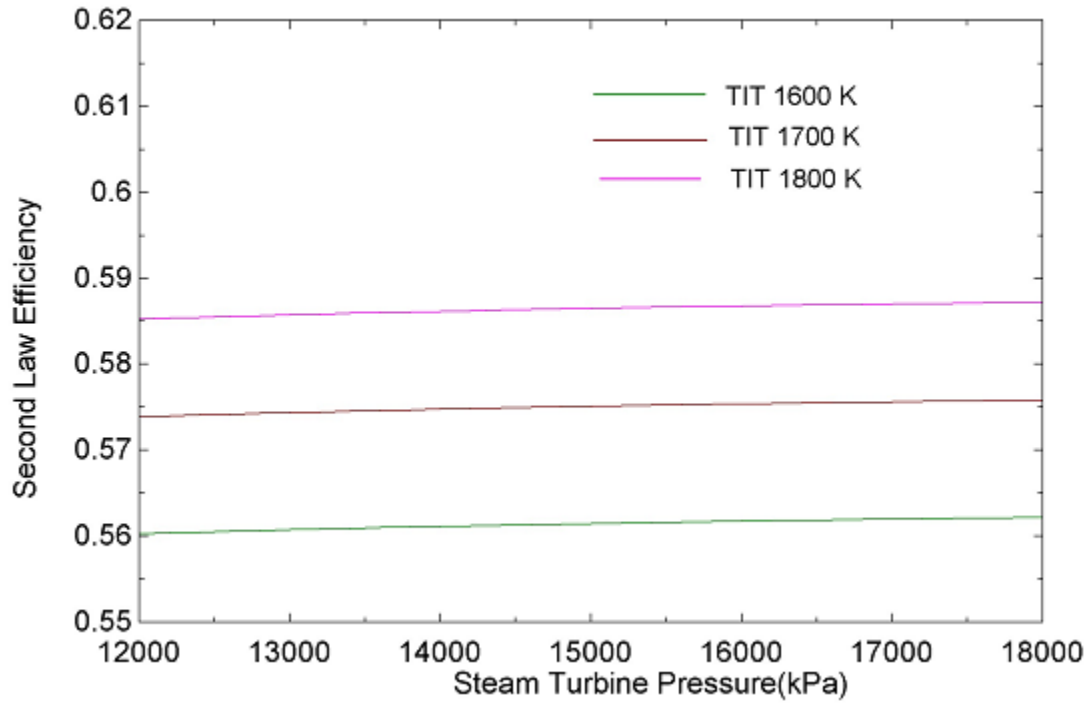

Fig 4.14 effect of steam turbine pressure on second law efficiency

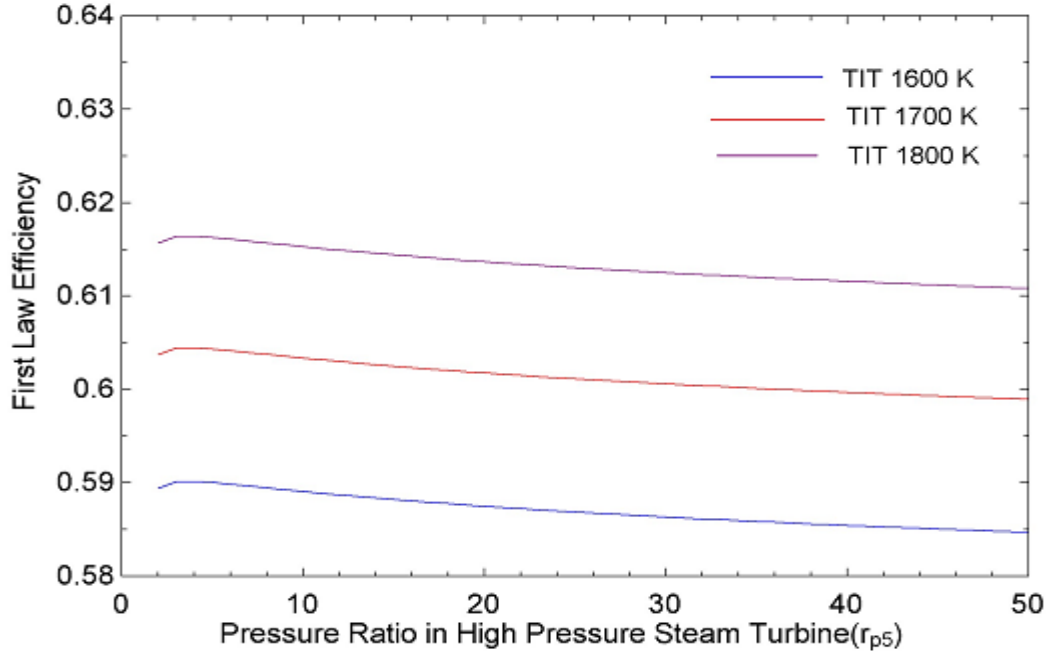

Fig 4.15 effect of pressure ratio of high pressure steam turbine on first law efficiency

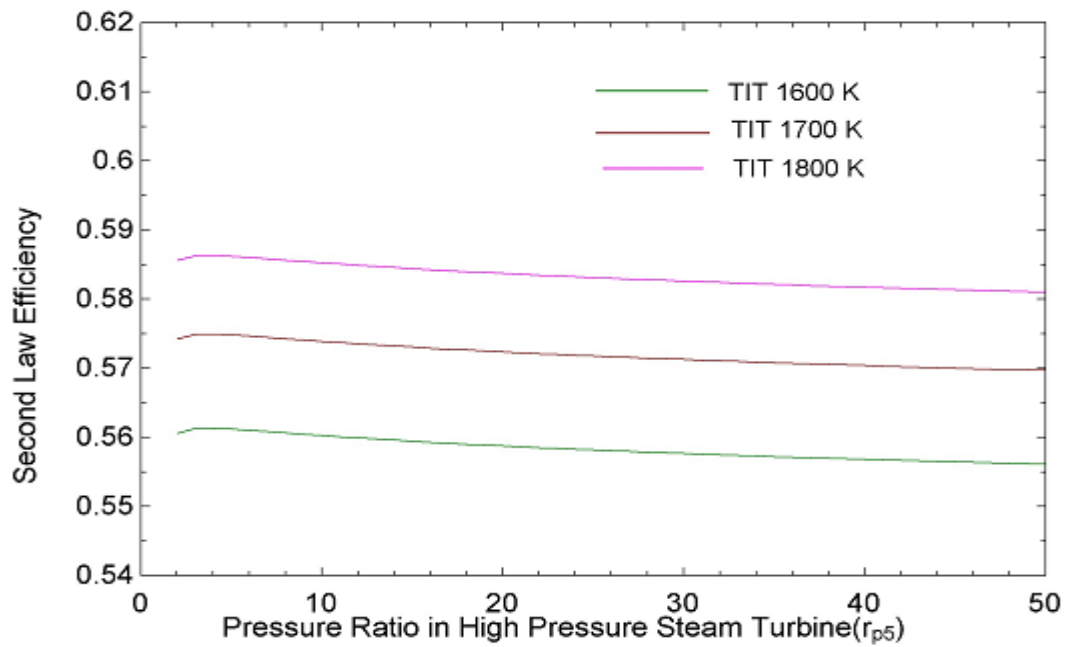

Fig 4.16 effect of pressure ratio of high pressure steam turbine on second law efficiency

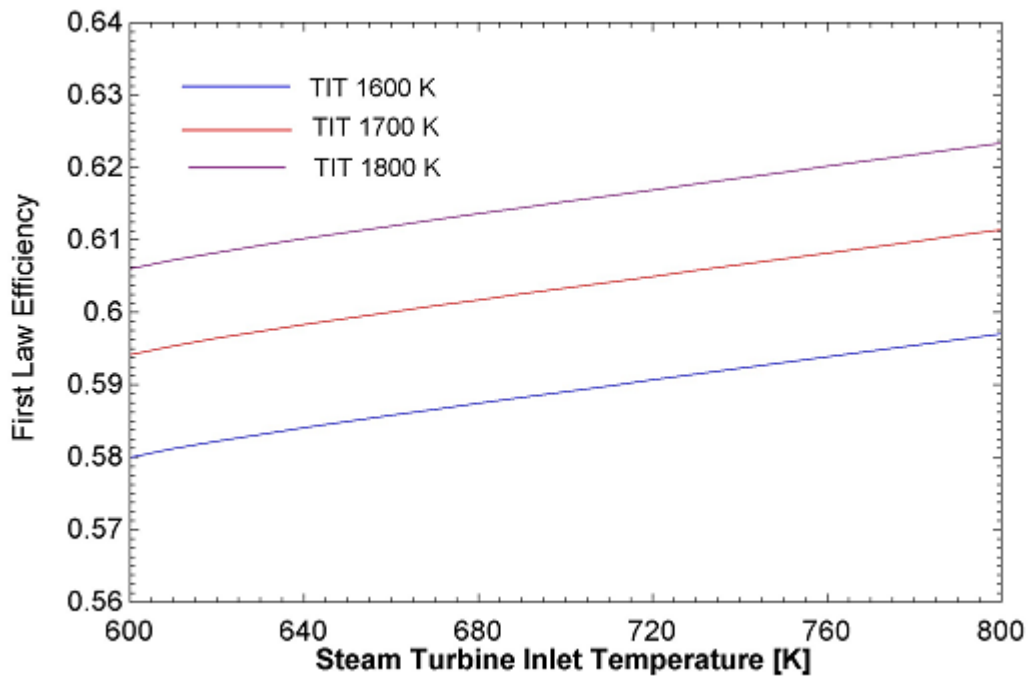

Fig 4.17 effect of steam turbine inlet temperature on first law efficiency

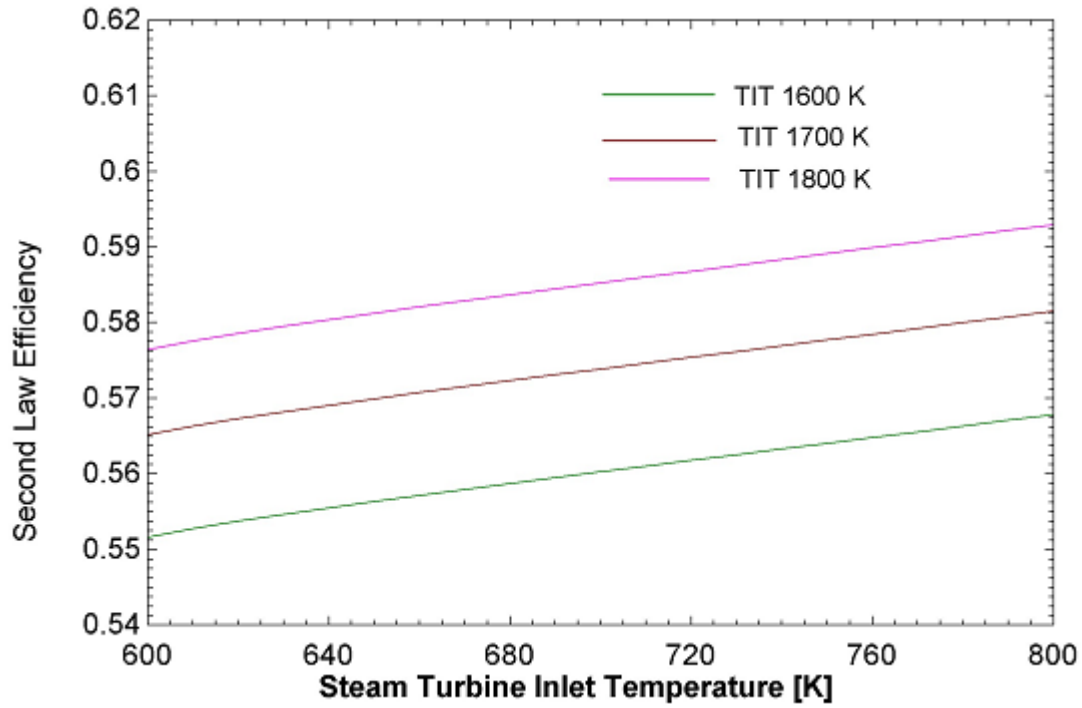

Fig 4.18 effect of steam turbine inlet temperature on second law efficiency

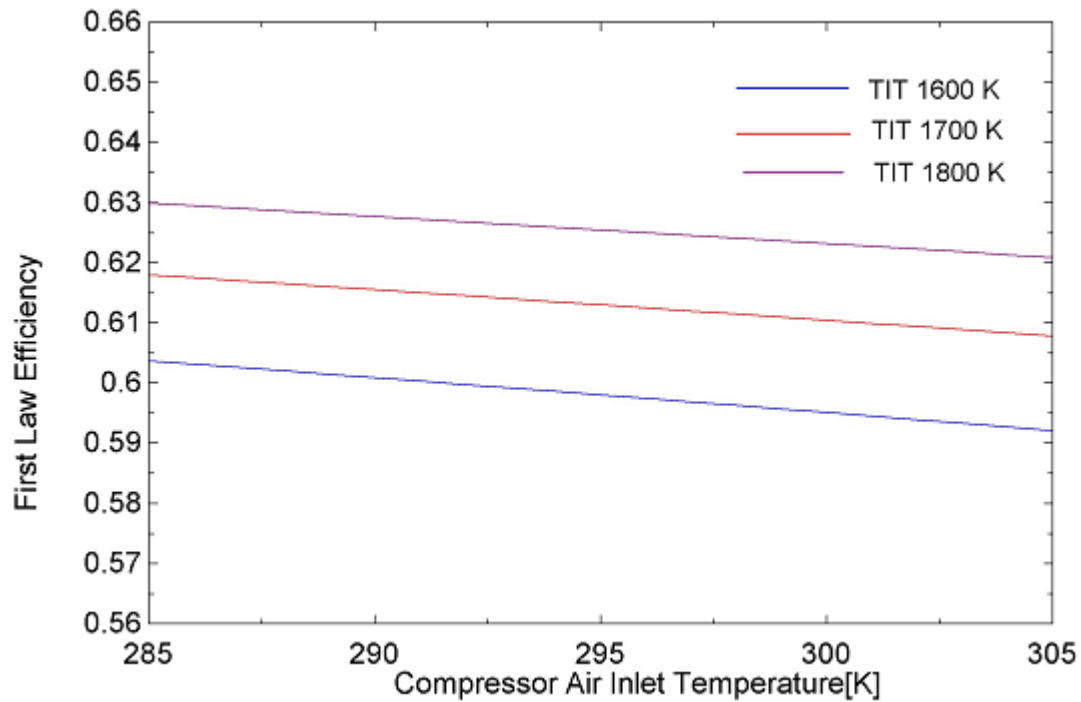

Fig 4.19 effect of compressor inlet air temperature on first law efficiency

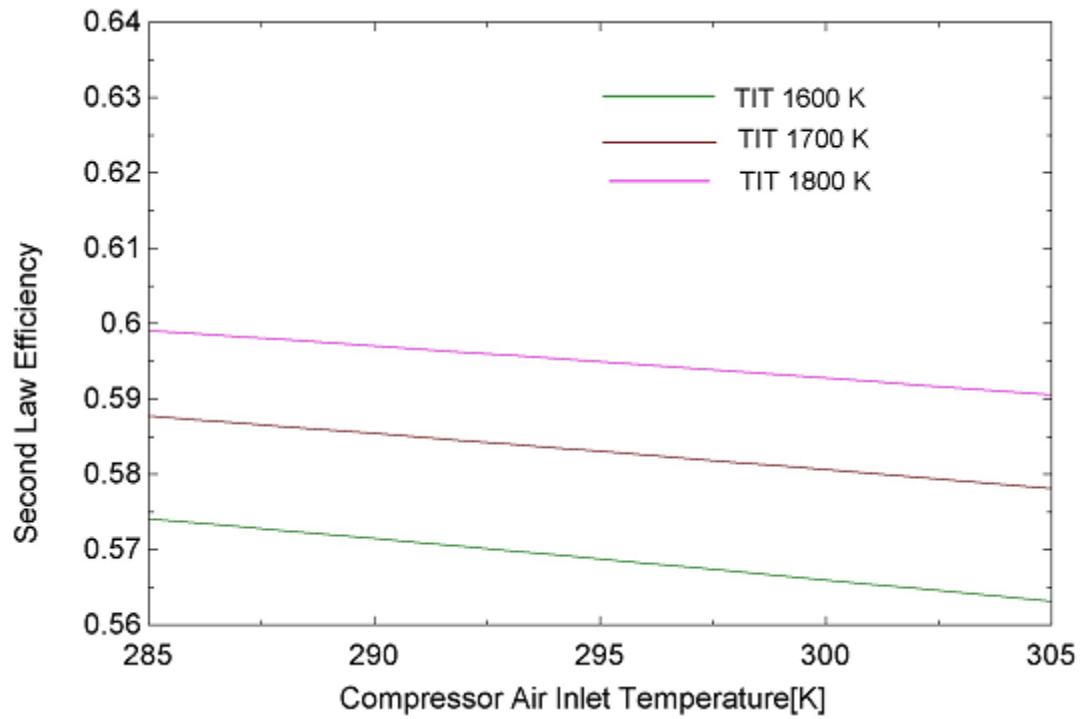

Fig 4.20 effect of compressor inlet air temperature on second law efficiency

CHAPTER 6

CONCLUSION AND RECOMMENDATIONS

In this work, thermodynamic analysis of combined cycle gas turbine is done. Energetic and Exergetic analysis is done find ways to improve plant's efficiency and reduce the exergy destruction rate of components.

For given plant's requirement, when analyzed with simple combined cycle gas turbine, the first law efficiency obtained is 50.28%, and when analyzed with modified combined cycle gas turbine, the improved efficiency obtained is 55.51%. By exergy analysis it is found out that combustion chamber and duct burner have the highest exergy destruction rate.

From parametric study, it is found out that first law efficiency can be improved up to or more than 60% by choosing optimize parameter.

6.1 Conclusions

From this study following conclusion can be drawn:

1. By increasing the overall pressure ratio in topping cycle, first and second law efficiency can be increased.
2. To obtain high efficiency, pressure ratio in low pressure compressor should be low and high for high pressure compressor.
3. To achieve high efficiency, pressure ratio in high pressure gas turbine should be low and high for low pressure turbine.
4. By increasing the Gas Turbine Inlet Temperature, efficiency of turbine can be improved so TIT should be as high as possible.
5. Increase in steam turbine pressure has very minute effect (increase) on the efficiency of combined cycle.
6. As the value of steam turbine inlet temperature increases, the efficiency of cycle also increases. There is certain value of temperature, above that temperature there is sudden increase in efficiency. So steam turbine should work above that temperature.

7. Effect of pressure ratio in high pressure steam turbine on efficiency is minute but it should be low in high pressure steam turbine and high for low pressure steam turbine.
8. As the temperature of inlet air decreases, efficiency of cycle increases. because decrease in compressor work.
9. Exergy destruction rate is high for combustion chamber and duct burner.

6.2 Recommendations:

The recommendations for future research are as follows:

1. In this study steam turbine is used in bottom cycle. Other cycles such as Organic Rankine Cycle and Kalina cycle can also be analyzed.
2. As the efficiency depends on compressor inlet air temperature, solar powered VARS can be employed to cool the inlet air in summer.
3. Steam injection system can be used for cooling of gas turbine blade, so that TIT can be increased.
4. Use more innovative combustion process in combustion chamber.
5. Optimization of HRSG.
6. The emissions from the CCPP system can be reduced by, for example, using a more efficient Stack after HRSG or switch to the biomass fuel. However, by considering the carbon natural cycle, the CO₂ emissions from the biomass fuel could be considered having lesser environmental impact.

REFERENCES

- [1] Chase D.L. and Kehoe P.T. GE Power Systems Schenectady, NY GE Combined-Cycle Product Line and Performance
- [2] Yunus Cengel and Micheal Boles, Thermodynamics: An Engineering Approach
- [3] Ahmadi P., Dincer I., Exergoenvironmental Analysis and Optimization of a Cogeneration Plant System using Multimodal Genetic Algorithm (MGA). *Energy*, 35(2010), pp. 5161-72.
- [4] Boyano A., Blanco-Marigorta A. M., Morosuk T., Tsatsaronis G., Exergoenvironmental Analysis of a Steam Methane Reforming Process for Hydrogen Production. *Energy*, 36(2011), pp. 2202-2214.
- [5] Petrakopoulou F., Boyano A., Cabrera M., Tsatsaronis G., Exergoeconomic and Exergoenvironmental Analyses of a Combined Cycle Power Plant with Chemical Looping Technology. *International Journal of Greenhouse Gas Control*, 5(2011), pp. 475-482.
- [6] Hasan Naimul, Rai Jitendra Nath and Arora B. B. 2014 Optimization of CCGT power plant and performance analysis using MATLAB/Simulink with actual operational data. SpringerPlus 2014, 3:275, 1-9
- [7] Ibrahim K. T., Rahman M. M., Abdalla N. A., Optimum Gas Turbine Configuration for Improving the Performance of Combined Cycle Power Plant. *Procedia Engineering*, 15(2011), pp.4216-4223.
- [8] Ameri M., Hejazi H. S., The Study of Capacity Enhancement of the Chabahar Gas Turbine Installation using an Absorption Chiller. *Applied Thermal Engineering*, 24(2004), pp.59–68.
- [9] Boonnasa S., Namprakai P., Muangnapoh T., Performance Improvement of the Combined Cycle Power Plant by Intake Air Cooling using an Absorption Chiller, *Energy*, 31(2006), pp. 2036–2046.

- [10] Hosseini R., Beshkanl. A., Soltani M., Performance Improvement of Gas Turbines of Fars (Iran) Combined Cycle Power Plant by Intake Air Cooling using a Media Evaporative Cooler. *Energy Conversion and Management*, 48(2007), pp. 1055–1064.
- [11] Ibrahim T. K., Rahman M. M., Effect of Compression Ratio on Performance of Combined Cycle Gas Turbine. *International Journal of Energy Engineering*,2(2012)1, pp. 9-14.
- [12] Khaliq A., Kaushik S., Thermodynamic Performance Evaluation of Combustion Gas Turbine Cogeneration System with Reheat. *Applied Thermal Engineering*, 24(2004), pp. 1785–1795.
- [13] Sanjay, Investigation of Effect of Variation of Cycle Parameters on Thermodynamic Performance of Gas-Steam Combined Cycle. *Energy*, 36(2011), pp. 157-167.
- [14] Khaliq A., Exergy Analysis of Gas Turbine Trigeneration System for Combined Production of Power Heat and Refrigeration. *International Journal of Refrigeration*, 32(2009), pp. 534-545.
- [15] Kaviri A. G., Jaafar M. N., Lazim, T. M., Modeling and Multi-Objective Exergy Based Optimization of a Combined Cycle Power Plant using a Genetic Algorithm. *Energy Convers Manage*, 58(2012), pp. 94-103.
- [16] Mohagheghi M., Shayegan J., Thermodynamic Optimization of Design Variables and Heat Exchangers Layout in HRSGs for CCGT, using Genetic Algorithm. *Applied Thermal Engineering*, 29(2009), pp. 290–299.
- [17] Bracco S., Silvia S., Exergetic Optimization of Single Level Combined Gas Steam Power Plants Considering Different Objective Functions. *Energy*, 35(2010), pp. 5365-5373.
- [18] Woudstra N., Woudstra T., Pirone A., Van der Stelt T., Thermodynamic Evaluation of Combined Cycle Plants. *Energy Conversion and Management*, 51(2010)5, pp. 1099–1110.
- [19] Mansouri M. T., Ahmadi P., Kaviri A. G., Exergetic and Economic Evaluation of the Effect of HRSG Configurations on the Performance of Combined Cycle Power Plants. *Energy Conversion and Management*, 58(2012), pp. 47–58.

[20] Tyagi K. P., Khan M. N., Effect of Gas Turbine Exhaust Temperature, Stack Temperature and Ambient Temperature on Overall Efficiency of Combine Cycle Power Plant. *International Journal of Engineering and Technology*, 2(2010)6, pp. 427-429.

[21] Valdés M., Durán D. M., Antonio R., Thermoeconomic Optimization of Combined Cycle Gas Turbine Power Plants using Genetic Algorithms. *Applied Thermal Engineering*, 23(2003)17, pp. 2169-2182.

[22] Bassily A., Modeling and Numerical Optimizations, and Irreversibility Reduction of a Dual Pressure Reheat Combined Cycle. *Applied Energy*, 81(2005), pp. 127-151.

[23] Boonnasa S., Namprakai P., Muangnapoh T., Performance Improvement of the Combined Cycle Power Plant by Intake Air Cooling using an Absorption Chiller, *Energy*,31(2006), pp. 2036–2046.

[24] Cihan A., Hacihafızoglu O., Kahveci K., Energy–exergy analysis and modernization suggestions for a combined-cycle power plant, *Int. J. Energy Res.* 2006; 30:115–126