

A

Dissertation

On

**MODELLING OF UNIFIED POWER QUALITY
CONDITIONER (UPQC) FOR POWER QUALITY
IMPROVEMENT**

Submitted in Partial fulfilment of the requirement

For the award of the degree of

MASTER OF TECHNOLOGY

In

(Power System)



Submitted by

Ravish Kumar

Roll No. 2k11/PSY/16

Under the Guidance of

J. N. RAI

Department of Electrical Engineering

DEPARTMENT OF ELECTRICAL ENGINEERING

DELHI TECHNOLOGICAL UNIVERSITY

BAWANA ROAD, DELHI- 110042

July 2013

**DEPARTMENT OF ELECTRICAL ENGINEERING
DELHI TECHNOLOGICAL UNIVERSITY
BAWANA ROAD, DELHI**



CERTIFICATE

This is to certify that the work entitled, “**Modelling of Unified Power Quality Conditioner (UPQC) for Power Quality Improvement**” has been submitted for the fulfillment of the requirements for the award of Degree of M.Tech in Electrical Engineering (Power System), carried out by Ravish Kumar under my supervision, at Delhi Technological University.

To the best of my knowledge, the matter embodied in the dissertation has not been submitted to any other University/Institute for the award of any Degree or Diploma.

J.N. RAI
Department of Electrical Engineering
Delhi Technological University

CANDIDATE’S DECLARATION

I hereby certify that the work which is being presented in this dissertation entitled “**Modelling Of Unified Power Quality Conditioner (UPQC) For Power Quality Improvement**” by Ravish Kumar in the partial fulfillment of requirements for the award of Master of technology in Electrical Engineering (Power System), submitted to the Department of Electrical Engineering, Delhi Technological University, Delhi, is an authentic record of my own work carried out during a period of August 2012 to July 2013, under the supervision of J.N.RAI, Delhi Technological University. The matter presented in this dissertation has not been submitted to any other University/Institute for the award of M.Tech or any other Degree/Diploma.

Ravish Kumar

Roll No. 2K11/PSY/16

ACKNOWLEDGEMENT

I wish to express my profound sense of deepest gratitude to my guide and motivator J.N. RAI, Electrical Engineering Department, Delhi Technological University, Delhi for his valuable guidance, sympathy and co-operation and finally help for providing necessary facilities and sources during the entire period of this dissertation.

I wish to convey my sincere gratitude to Prof. Madhusudan Singh, HOD, Department of Electrical Engineering and all the faculties of Electrical Engineering Department who have enlightened me during my studies.

The facilities and co-operation received from the technical staff of Electrical Engineering Department is thankfully acknowledged.

I would like to thank all my friends and especially my classmates, for all the thoughtful and mind stimulating discussions we had, which prompted me to think beyond the obvious. I've enjoyed their companionship so much during my stay at DTU, Delhi.

Last but not least I would like to thank my parents who provide me enormous support during my whole stay in DTU, Delhi.

Ravish Kumar
M.Tech (Power System)
Roll No. 2K11/PSY/16

ABSTRACT

With the advent of power electronics and digital control technology, the renewable energy sources are increasingly being connected to the distribution systems in terms of wind, solar, hydro etc due to their free availability and low conversion cost. However, with the proliferation of the power electronics devices, unbalanced loads and nonlinear loads, the quality of the power evacuated from these renewable sources have degraded to large extent, which may often leads to distorted voltage and currents in the distribution network thereby affecting the reliability of the system.

Thus, stable operation of the distribution system amidst variety of unbalance at the connected load is a challenging task. Among various custom power devices, UPQC is considered to be the most promising solution for balanced operation of the system. It has the capability to offer control from both series as well as shunt end, thereby providing compensation to various power quality problems associated with the system.

The thesis proposes a control scheme for UPQC to enhance the quality and reliability of the electrical power generated in the distribution system particularly when connected to diode rectifier type non-linear load. Unified PQ conditioner (UPQC) is a versatile custom power device which consists of two VSCs connected back-to-back to compensate for both distorted PCC voltage and supply current imperfections. For a Non-Linear load, UPQC is designed to compensate the harmonic injected by the non-load from entering into the source terminal and regulation of voltage at the point of common is carried out by series connected converter. SRF based current control method is used for current compensation by the shunt device and Hysteresis voltage control technique is used for series device which simultaneously act as shunt and series active power filters. Also, maintaining a constant value for dc link voltage is necessary for UPQC to perform normally which is here carried out by shunt connected VSC. MATLAB based simulation is carried out to demonstrate the effectiveness of the proposed control scheme.

TABLE OF CONTENTS

Certificate	i
Candidates Declaration	ii
Abstract	iii
Acknowledgement	iv
List of Figures	v
List of Tables	vi

CHAPTER 1: INTRODUCTION	PAGE NO.
1.1. General	1
1.2. Power Quality	2
1.3. Electric Power Quality	3
1.3.1 Causes of PQ Deterioration	3
1.4. Need for Power Quality	3
1.5. Main Power Quality Problems/Issues	5
1.6. Sources of Power Quality Problems	5
1.7. Harmonics in Power System due to Non-Linear Load	5
1.8. Power Conditioning	6
1.9. Classification of Power Conditioner	7
1.9.1 AC Power Conditioner	7
1.9.2 Power Line Conditioner	7
1.10. Application of Power Conditioner	8
1.11. Active Power Filter	8
1.12. Control Techniques Used in Active Power Filter	10
1.13. Objectives	10
1.14. Literature Survey	10

1.15. Organization of Project	13
-------------------------------	----

CHAPTER 2: CUSTOM POWER DEVICES

2.1 Introduction	15
2.2 Introduction to Custom Power Devices	15
2.3 Network Reconfiguring Devices	16
2.3.1 Solid State Current Limiter	16
2.3.2 Solid State Breaker	17
2.3.3 Solid State Transfer Switch	17
2.4 Compensating Devices	
2.4.1 Load Compensating using DSTATCOM	18
2.4.2 Voltage Regulation using DSTATCOM	20
2.4.3 Protecting Sensitive Loads using DVR	20
2.4.4 Unified Power Quality Conditioner	21

CHAPTER 3: UNIFIED POWER QUALITY CONDITIONER

3.1 Introduction	24
3.2 Conventional Classification of UPQC	25
3.3 Relative Positions of Shunt and Series Active Filters In UPQC	26
3.4 Power Circuit Configuration and Operating Principle	28
3.5 Conclusion	29

CHAPTER 4: CONTROL STRATEGY

4.1 Introduction	31
4.2 Principle of Operation	31
4.3 Reference Signal Generation	33
4.3.1 Series Active Filter	33

4.3.2 Shunt Active Filter	33
4.4 Hysteresis Current Control Method	34
4.5 DC Link Capacitor	36

CHAPTER 5: RESULTS AND DISCUSSIONS

5.1 Introduction	37
5.2 Simulation Parameters	37
5.3 Simulation without UPQC	38
5.4 Simulation with UPQC	40
5.5 Simulation Results And Discussion	43
5.6 Performance Analysis	43

CHAPTER 6: CONCLUSION AND FUTURE SCOPE

6.1 Conclusions	45
6.2 Future Work	45
REFERENCES	46

LIST OF FIGURES

Fig. No.	Description
Fig.1.1.	Active power filter connected to non-linear load
Fig.1.2.	Block Diagram of UPQC
Fig.2.1.	Schematic diagram of a solid state current limiter
Fig.2.2.	Schematic diagram of a static transfer switch
Fig.2.3.	Schematic diagram of ideal load compensation
Fig.2.4.	(a) Ideal voltage controller
Fig.2.4	(b) its practical realization
Fig.2.5.	Schematic diagram of a sensitive load protected by a DVR
Fig.2.6.	(a) Schematic diagram of a UPQC compensated system,
Fig.2.6.	(b) & (c) two alternate connections
Fig.3.1.	Left shunt UPQC
Fig.3.2.	Types of topologies of UPQC
Fig.3.3.	A typical UPQC system connected with energy storage
Fig.4.1.	Connection diagram of UPQC
Fig.4.2.	Equivalent single-phase circuit corresponding to harmonic
Fig.4.3.	Simulation scheme for hysteresis current control
Fig.4.4.	Pulse generation by hysteresis band control
Fig 5.1	Simulation model of rectifier fed RL load connected at PCC without UPQC.
Fig. 5.2.	Load Voltage and Source Current without UPQC
Fig.5.3.	THD in source current without UPQC.
Fig.5.4.	THD in Load voltage without UPQC.
Fig.5.5.	Simulation model of circuit with rectifier fed RL load using UPQC.
Fig.5.6.	Load Voltage and Source Current waveform with UPQC
Fig.5.7.	THD in Load Voltage using UPQC.
Fig.5.8.	THD in source current using UPQC.
Fig.5.9.	DC Link Voltage

LIST OF TABLES

Table 1.1	PQ Problems and their causes
Table 1.2	Power Quality (PQ) Standards
Table 5.1	System Parameters
Table 5.2	Simulation result
Table 5.3	Performance analysis of UPQC

INTRODUCTION

1.1 GENERAL

The growing use of non-linear and time varying loads has led to distortion of voltage and current waveforms and increased reactive power demand in AC mains. Distortion due to harmonics is known to be source of several problems, such as increased power losses, excess heating in rotating machinery, flicker and audible noise, significant interference with communication circuits, and incorrect operation of sensitive loads [1-2]. Power electronics based equipment which includes adjustable-speed motor drives, DC motor drives, electronic power supplies, electronic ballasts, battery chargers are responsible for the rise in power quality related problems. The main power quality related problems are harmonic distortion, temporary interruptions, voltage sag, voltage swell, under voltages, voltage spikes and noise [3-4]. The non-linear loads appear to be prime sources of harmonic distortion in a power distribution system.

As the harmonic currents pass through the line impedance of the system, harmonic voltages appear, causing distortion at the coupling point. Harmonics have a number of undesirable effects on the distribution system (such as additional power losses). They fall into two basic categories: short term and long term. Short-term effects are usually the most noticeable and are related to excessive voltage distortion. On the other hand, long-term effects often go undetected and are usually related to increased resistive losses or voltage stress. In addition, the harmonic currents produced by nonlinear loads can interact adversely with a wide range of power system equipment, most notably capacitors, transformers and motors, causing additional losses, overheating and overloading. Harmonic currents can also produce errors in telecommunication lines. As the presence of harmonics in grid system is harmful, so there is need to define a framework to suppress it [5-6]. Suppression of harmonics involve two approaches, namely, passive and active powering.

1.2 POWER QUALITY

Power quality is the set of limits of electrical properties that allows electrical systems to function in their intended manner without significant loss of performance. The term is used to describe electric power that drives an electrical load and the load's ability to function properly. With Unreliable power, an electrical device (or load) may malfunction, prematurely fail or not operate at all. Electric power can be of poor quality in many ways and many more causes of such poor quality power.

The electric power industry comprises electrically (A.C. power) generation, electric power transmission and ultimately electricity distribution to an electricity meter located at the premises of the end user until it reaches the load. The complexity of the system to move electric energy from the point of production to the point of consumption combined with variations in generation, weather, demand and other factors provide many opportunities for the quality of supply to be compromised.

While power quality is a convenient item for many, it is quality of voltage rather than power or electric current that is actually described by the term. Power flow is simply the flow of energy and the current demanded by a load is largely uncontrollable.

Electrical power quality may be described as a set of values of parameters such as:

- ❖ Continuity of service
- ❖ Variation in voltage magnitude
- ❖ Transient voltages and currents
- ❖ Harmonic content in the waveforms

Often it is useful to think of power quality as a compatibility problem: is the equipment connected to the grid compatible with the events on the grid, and is the power delivered by the grid, including the events, compatible with the equipment that is connected? Compatibility problems always have at least two solutions: in this case, either clean up the power, or make the equipment tougher.

1.3 ELECTRIC POWER QUALITY

The term Electric power quality broadly refers to maintaining a near sinusoidal power distribution bus voltage at rated magnitude and frequency[18]. Hence, the energy supplied to a customer must be uninterrupted from the reliability point of view. Even though Power Quality is mainly a distribution system problem, power transmission systems may also have an impact on the quality of power.

- To maintain the power distribution bus voltages to near sinusoidal waveform at rated voltage magnitude & frequency.
- It is a measure of how well electric power can be utilized by customers.

1.3.1 Causes of PQ Deterioration

Each of these power quality problems has different causes. Some problems are a result of the shared roots. For example, a fault on the network may cause a dip that will affect some customers; the higher the level of fault, the greater the number of people affected. A problem on one customer's site may cause a transient that affects all other customers on the same subsystem. Then harmonics arise within the customer's own installation and may propagate onto the network and affect other customers or loads. Harmonic problems can be dealt with by a combination of good design practices and well proven reduction equipment.

They can be divided into two categories:

1. **Natural Causes:** Faults or lightning strikes on transmission lines or distribution feeders, falling of trees or branches on distribution feeders during stormy conditions, equipment failure, etc.
2. **Due to load or transmission line/feeders operation:** Transformer energization, capacitor or feeder switching, power electronic loads (UPS, ASD, Converters, etc.) are induction heating and furnaces systems, switching on or off of large loads, etc.

1.4 NEED FOR POWER QUALITY

- In the recent years, Power quality (PQ) has become a significant issue for both power suppliers and customers[33].
- There have been three important changes in relation to Power Quality.

- Firstly, the characteristics of load have become so complex that the voltage and current of the power line connected with these loads are easy to be distorted.
- Lately, non-linear loads with power electronic interface that generate large harmonic current have been greatly increased in power system.
- Next, the end-user equipment have become more sensitive to power quality than before.

Sr. No.	Broad Categories	Specific Categories	Methods of characterization	Typical causes
1.	Transients	i) Impulsive ii) Oscillatory	i) Peak magnitude, rise time and duration ii) Peak magnitude, frequency components	i) Lightning strike, transformer energization, capacitor switching ii) Line or capacitor or load switching
2.	Short duration voltage variation	i) Sag ii) Swell iii) Interruption	i) Magnitude, duration ii) Magnitude, duration iii) Duration	i) Ferro resonant transformers ,single line to ground fault ii) Ferro resonant transformers ,single line to ground fault iii) Temporary(Self-clearing) Faults
3.	Long duration voltage variation	i) Under-voltage ii) Over-voltage iii) Sustained Interruptions	i) Magnitude, duration ii) Magnitude, duration iii) Duration	i) Switching on loads, capacitor de-energization ii) Switching off loads, capacitor energization iii) Faults
4.	Voltage Imbalance		Symmetrical Components	Single-phase loads, Single phasing condition
5.	Waveform Distortion	i) Harmonics ii) Notching iii) DC offset	i) THD, Harmonic spectrum ii) THD, Harmonic spectrum iii) Volts, Amps	i) Adjustable speed drives and other non-linear loads ii) Power electronic converter iii) Geomagnetic disturbance, half wave rectification

6.	Voltage Flicker		Frequency of occurrence, modulating frequency	Arc furnace, arc lamps
----	-----------------	--	---	------------------------

Table 1.1 PQ Problems and their causes

1.5 MAIN POWER QUALITY PROBLEMS/ISSUES

- Harmonic Distortion
- Momentary interruptions
- Temporary interruptions
- Long Term Outage
- Noise
- Voltage sag
- Voltage swell
- Voltage spikes
- Under Voltages

1.6 SOURCES OF POWER QUALITY PROBLEMS

- Power electronic devices
- IT and office equipment
- Arching devices
- Load switching
- Large motor starting
- Embedded generation
- Sensitive equipment
- Storm and environmental related damages

1.7 HARMONICS IN POWER SYSTEM DUE TO NON-LINEAR LOADS

The main source of voltage and current harmonics are due to control and energy conversion techniques involved in power electronic devices such as chopper, rectifier,

cyclo-converter etc[32]. The harmonic sources are energy conversion devices such as power factor improvement and voltage controller devices of motor, high voltage DC converters, wind and solar powered DC/AC converters, direct energy fossil fuel cells, control of heating elements. Due to use of non-linear loads like rectifier, chopper, etc. the load current gets distorted.

1.8 POWER CONDITIONING

Power conditioning is modifying the power to improve its quality. An uninterruptible power supply can be used to switch off of mains power if there is a transient (temporary) condition on the line.

Sr. No.	Topic	Standards
1.	Classification of Power Quality	IEC 61000-2-5 :1995, IEC 61000-2-1 :1990 IEEE 1159 :1995
2.	Transients	IEC 61000-2-1 :1990 IEEE C 62.41 : (1991) IEEE 1159 : 1995 IEC 816 :1984
3.	Voltage sag/swell and Interruptions	IEC 61009-2-1 :1990, IEEE 1159 :1995
4.	Harmonics	IEC 61000-2-1 :1990 IEEE 519 :1992 IEC 61000-4-7 :1991
5.	Voltage flicker	IEC 61000-4-15 :1997

Table 1.2 Power Quality (PQ) Standards

However, cheaper UPS units themselves create poor quality power, akin to imposing a higher frequency and lower amplitude square wave atop the sine wave. Whereas High quality UPS units utilize a double conversion topology which breaks down incoming AC power into DC, charges the batteries, then remanufactures an AC sine wave. This remanufactured sine wave is of higher quality than the original AC power feed. A surge protector or simple capacitor can protect against most overvoltage conditions, where a lightning arrester protects against severe spikes. Electronic filters can remove harmonics.

A power conditioner is a device intended to improve the quality of the power that is delivered to electrical load equipment. Where there is no official definition of the power conditioner, the term most often refers to a device that acts in one or more ways to deliver the voltage to the proper level and characteristics to enable the load equipment to function properly. In some usages, power conditioner refers to a voltage regulator with at least one other function to improve power quality (e.g. Power factor correction, transient impulse protection, noise suppression, etc.).

The terms “power conditioning” and “power conditioner” can be misleading, as the word “power” here refers to the electricity generally rather than the more technical electrical power. Conditioner specifically works to smooth the sinusoidal AC waveform and maintain a constant voltage over varying loads.

1.9 CLASSIFICATION OF POWER CONDITIONER

1.9.1 AC Power Conditioner

An AC power conditioner is the typical power conditioner that provides “clean” AC power to sensitive electrical equipment. Generally this is used for home or office applications and has up to 10 or more receptacles or outlets and commonly provides surge protection as well as noise filtering.

1.9.2 Power Line Conditioners

Power line conditioners take in power and modify it based on the requirements of the machinery to which they are connected. During power storms or other malfunctions the voltage spikes are most common in the main power lines. Surge protectors stop the flow of electricity from reaching machines by shutting off the power source.

1.10 APPLICATION OF POWER CONDITIONER

Power conditioners can vary greatly in specific functionality and size, with both parameters generally determined by application. Some power conditioner provides only minimal voltage regulations while other provides protection from half a dozen or more power quality problems. Units may be small enough to mount on a printed circuit board or large enough to protect an entire factory. Small power conditioners are rated in volt-ampere (VA), while large units are rated in kilovolt-amperes (KVA).

1.11 ACTIVE POWER FILTER

Series active filter is combination of power electronic (Active) elements which are tuned at a particular frequency. In recent years due to advancement in power electronics Silicon Controlled Rectifiers (SCR), IGBT, CSI, VSI etc. are being used in place of conventional L and C [36]. These are compact in size and more efficient. So the application of such semiconductor devices is very popular in industry as well as in domestic purposes.

To provide clean power at the consumer end active power filter (APF) is used. Digital domain like micro-controller, digital signal processing and field programmable gate array implemented to the APF giving a number of advantages compared to analog controllers. Fig. 1.1 shows an active power filter connected to the power system at the PCC [37].

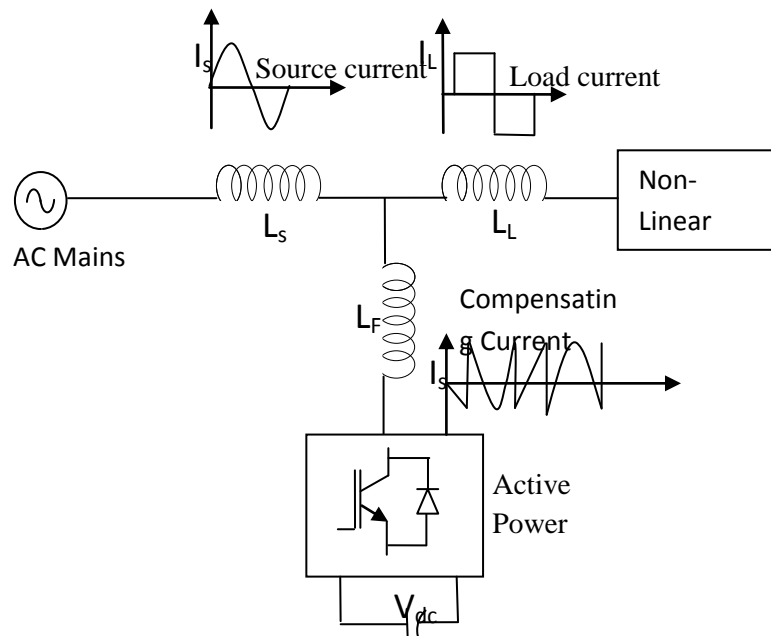

Fig.1.1. Active power filter connected to non-linear load

Due to the use of non-linear load the waveform of voltage at PCC gets distorted. The compensating voltage which is the output of APF is injected at PCC by the use of series injection transformers which presents high impedance for the harmonic component of voltage [34]. The APF is a popular approach for cancelling the harmonics in power system.

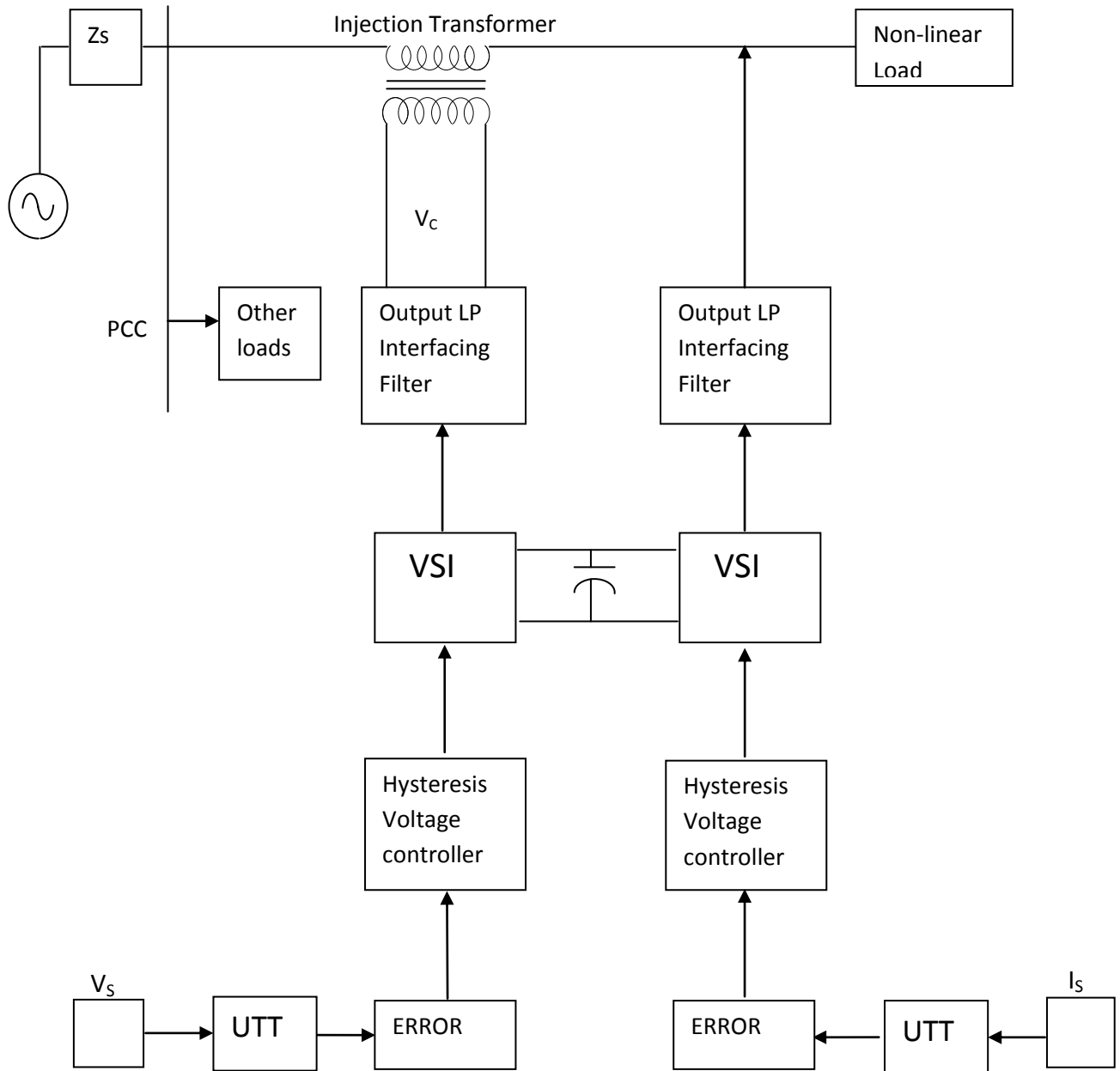

Fig.1.2. Block Diagram of UPQC

Block Diagram of UPQC is shown in Fig.1.2. The UPFC is employed in the power transmission system to perform shunt and series compensation at the same time.

1.12 CONTROL TECHNIQUES USED IN ACTIVE POWER FILTER

Designing a suitable controller for an APF is very important. A number of control strategies such as instantaneous reactive power theory initially developed, synchronous frame d-q theory, synchronous detection method, notch filter and fuzzy logic controller are used in the developments of three-phase APFs and the gate pulses are generated by current control techniques like Sinusoidal Pulse Width Modulation (SPWM), Triangular PWM, Hysteresis Current Control Techniques and SVPWM Technique.

1.13 OBJECTIVES

The following objectives are hopefully to be achieved at the end of project.

- To design a MATLAB/SIMULINK model with non-linear load connected at PCC, and to calculate total Harmonic distortion in source current and voltage at PCC.
- To design a MATLAB/SIMULINK model of UPQC for the system and connect it to the system, which improves the overall power quality of the system.

1.14 LITERATURE SURVEY

The investigator has gone through a number of literatures in this regard. Some of them are discussed below:

Yash Pal and A. Swaroop and Bhim Singh et al [1], this paper deals with a Unified Power Quality Conditioner (UPQC) for load balancing, power factor-correction, voltage regulation, voltage and current harmonics mitigation, mitigation of voltage sag, swell and voltage dip in a three-phase three-wire distribution system for different combinations of linear and non-linear loads. The unit template technique (UTT) is used to get the reference signals for series APF, whereas the control algorithm for shunt APF utilizes two closed loop PI controllers. The control algorithm for shunt APF is made flexible so that it can correct supply power factor, eliminate harmonics, provide load balancing and also improve the load terminal voltage at point of common coupling (PCC). MATLAB/Simulink based simulation results are presented, which support the functionality of the UPQC.

Arindam Ghosh and Gerard Ledwich et al [2], this book discuss the power quality enhancement using custom power devices. It deals with the theory of network reconfiguring devices and compensating devices such as DVR, DSTATCOM and UPQC.

Vikash Anand and Dr. S.K. Shrivastava et al [3], this paper presented a series active harmonic compensator which compensates the harmonic contents present in load voltage at PCC. This paper uses UTT Theory to generate reference signal and hysteresis current control method to for trigger pulses of VSI. A VSI is used as series active power filter. This is controlled so as to draw or inject compensating voltage component V_c from or to the supply, such that it cancels voltage harmonics at source side.

Bhim Singh and Vishal Verma et al [4], this paper discusses the indirect current control approach in terms of its simplicity and effectiveness for the operation of a series APF. The simulated results show that a relatively low power series APF, with the indirect current control effectively compensates harmonics for the voltage fed type harmonics producing load. It is also investigated that series active filter is able to self-support its DC bus through the control under varying load connected to rectifier.

Moinuddin K. Sayed and Dr. BV Shanker Ram et al [5], this paper envisaged on the simulation of instantaneous active and reactive theory based shunt active filter with MATLAB/ Simulink, as a better solution for reduction of the harmonics.

Norman Mariun, Ahsanul Alam, Senam Mehmod and Hashim Hiram et al [6], Active power filter appears to be a viable solution for power quality conditioning. With the emergence of fast computing devices, control strategies for native filters are continually changing aiming at near perfect compensation. This paper presents a review of the state-of-the-art control techniques in active filters and reactive power compensation. Considerable attention is paid to the reference voltage/current estimation and control strategies. Several techniques are discussed and compared in terms of performance and implementation.

Juan W. Dixon and Luis A. Moran et al [7], A series active power filter working as a sinusoidal current source, in phase with the mains voltage, has been developed and tested. The amplitude of the fundamental current in the series filter is controlled

through the error signal generated between the load voltage and a pre-established reference. The control allows an effective correction of power factor, harmonic distortion, and load voltage regulation. Compared with previous methods of control developed for series active filters, this method is simpler to implement, because it is only required to generate a sinusoidal current, in phase with the mains voltage, the amplitude of which is controlled through the error in the load voltage. The proposed system has been studied analytically and tested using computer simulations and experiments. In the experiments, it has been verified that the filter keeps the line current almost sinusoidal and in phase with the line voltage supply. It also responds very fast under sudden changes in the load conditions, reaching its steady state in about two cycles of the fundamental.

L. H. Tey, and P. L. So et al [8], this paper deals with the design, hardware implementation of two types of single-phase filter. The first type is the active shunt filter for compensating harmonic currents generated by non-linear loads. The second type is the active series filter for eliminating harmonics inherent in the voltage source. The topology of the filter is based on a single-phase voltage source inverter (VSI) with four IGBT semiconductor switches. Simple time-domain extraction techniques are used to determine the harmonic components present in the load current or source voltage. The pulse-width-modulated (PWM) technique is then used to generate the required gate drive signals to the full- bridge VSI. A low-pass filter is also incorporated in the output of the inverter to provide a sufficient attenuation of the high switch in ripples caused by the VSI.

Hui Yan, Jun Li, and Guoqing Tang et al [9], this paper deals with series power quality compensator (SPQC), a power electronic equipment designed to mitigate voltage disturbances in forms of voltage sags, voltage swells, and voltage harmonics. The SPQC injects series voltage to eliminate the voltage disturbances by combining series inverters with a de-link capacitor and a shunt rectifier. A basic model of the SPQC is set up by using the state-space averaging method and the influence of low-pass filter and injection transformer are considered. Diagrams of control strategies are analysed based on state space averaging model. Due to the existence the inductance and the resistance of the series filter and the series transformer, there is error existing inevitably in the open loop control strategy. In order to improve the performance, a source current feedback control strategy for inverters is proposed.

Enio R. Ribeiro and Ivo Barbi et al [10], this paper proposes a series active filter using a simple control technique. The series active filter is applied as a controlled voltage source contrary to its common usage as variable impedance. It reduces the terminal harmonic voltages, supplying linear or even nonlinear loads with a good quality voltage waveform. The operation principle, control strategy, and theoretical analysis of the active filter are presented. These aspects were proven by the results of numerical simulations. Experimental results of the series active filter demonstrated its good performance under different load conditions.

P. Salmeron and S. P. Litran et al [11], control algorithm for a three-phase hybrid power filter is proposed. It is constituted by a series active filter and a passive filter connected in parallel with the load. The control strategy is based on the vectorial theory dual formulation of instantaneous reactive power, so that the voltage waveform injected by the active filter is able to compensate the reactive power and the load current harmonics and to balance asymmetrical loads. The proposed algorithm also improves the behaviour of the passive filter.

S.P. Litran, P.Salmeron, R.S. Harrera, J.R. Vazquez et al [12], the Active Power Filter in series connection are series APF, are static compensation systems based on an electronic converter PWM. The systematic use of series APF in the power system allows the elimination of harmonics caused by specific loads named voltage source harmonic loads. In this work the whole system model has been obtained. Besides, the system behaviour has been analysed from the state equations for each compensation strategy. As a consequence the analysis has slowed the establishment of design rules respect to the resultant control strategy.

1.15 ORGANIZATION OF PROJECT

The project is organized into 6 chapters including the chapter of introduction. Each chapter is described along with the necessary theory required to comprehend it.

Chapter 1: Introduction: The first chapter gives a brief introduction of the various problems caused by the non-linear loads in the power system. A brief description of the filters to improve the power quality along with the Literature survey has also been presented.

Chapter 2: Custom Power Devices: This second chapter deals with the basic theory of network reconfiguring devices and compensating devices such as DVR, DSTATCOM and UPQC.

Chapter 3: Unified Power Quality Conditioner: This chapter describes UPQC and classification of UPQC configurations. Further, it deals with the principle of compensation to the problems caused by the increasing of load and non-linear equipment in a modern power system in their respective fashion.

Chapter 4: Control Strategy: This chapter deals with the hysteresis Current Control scheme. For reference signal generation UTT theory has been used.

Chapter 5: Result and Discussion: In this chapter the simulations of the circuits using MATLAB/SIMULINK have been presented. The results derived from the simulations have also been included.

Chapter 6: Conclusion and Future Scope: This chapter gives the conclusion of the project been undertaken. The future scope of the work is also included.

CUSTOM POWER DEVICES

2.1 INTRODUCTION

The concept of custom power was introduced by N.G. Hingorani. Like flexible AC transmission systems (FACTS) for transmission systems, the custom power (CP) pertains to the use of power electronics controllers for distribution systems. Just as FACTS improves the reliability and quality of power transmission by simultaneously enhancing both power transfer stability and volume, the custom power enhances the quality and reliability of power that is delivered to customers. In this scheme a customer receives a pre-specified quality power. This pre-specified quality may contain a combination of specifications of the following-

- Frequency of rare power interruptions.
- Magnitude and duration of over and under-voltages within specified limits.
- Frequency of the supply voltage within specified limits.
- Low harmonic distortion in the supply voltage.
- Low phase unbalance.
- Low flicker in the supply voltage.

There are many custom power devices. The compensating power electronic devices are either connected in shunt or in series or a combination of both. In addition there are current breaking devices that are power electronic based. Any one or a combination of two or more of these devices is used to fulfil each one of the above mentioned objectives. In this chapter we shall introduce the concept of all these custom power devices.

2.2 INTRODUCTION TO CUSTOM POWER DEVICES

The power electronic controllers that are used in the custom power solution can be network reconfiguring type or compensating type. The network reconfiguring devices are usually called switchgear and they include current limiting, current transferring and current breaking devices. The solid state or static versions of the devices are called-

- Solid state current limiter (SSCL)
- Solid state breaker (SSB)
- Solid state transfer switch (SSTS)

The compensating devices either compensate a load, i.e correct its power factor, unbalancing, or improve the quality of the supplied voltage. Mentioned devices are either connected in shunt or in series or a combination of both shunt and series. The devices include-

- Distributed STATCOM (DSTATCOM)
- Dynamic voltage restorer (DVR)
- Unified power quality conditioner (UPQC)

2.3 NETWORK RECONFIGURING DEVICES

The network reconfiguring devices are usually called switchgear and they include the following-

2.3.1 Solid state current limiter (SSCL)

The schematic diagram of a solid state current limiter is shown in Fig. 2.1. It consists of pair opposite poled switches in parallel with the current limiting inductance L_m . In addition a series RC combination with a resistance of R_s and a capacitance of C_s is connected in parallel with the opposite poled switch [12]. The RC combination constitutes the unpolarised snubber network.

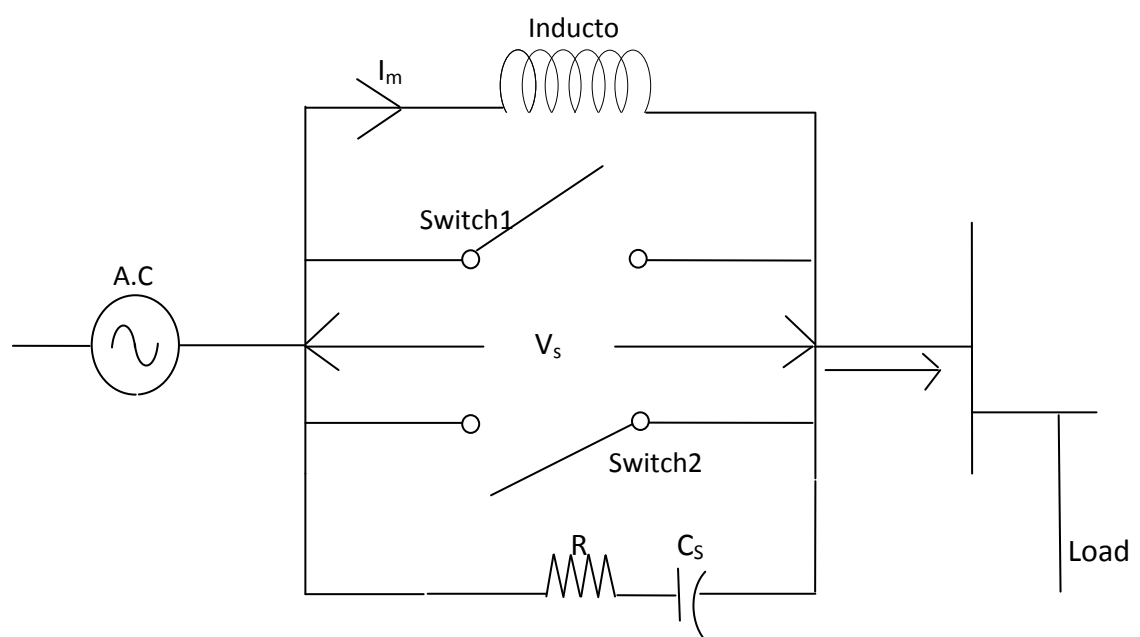

Fig. 2.1. Schematic diagram of a solid state current limiter

The current limiter is connected in series with a feeder such that it can restrict the current in case of a fault downstream. In the healthy state the opposite poled switch remains closed. These switches are opened when a fault is detected such that the fault current now flows through the current limiting inductor.

2.3.2 Solid state breaker (SSCB)

A solid state circuit breaker (SSCB) has almost the same topology as that of an SSCL except that the limiting inductor is connected in series with an opposite poled thyristor pair. The thyristor pair is switched on simultaneously as the bidirectional switch is switched off once a fault is detected. This will force the fault current to flow through the limiting inductor in the same manner as discussed above. The thyristor pair is blocked after a few cycles if the fault still persists. The current through the thyristor pair will cease to flow at the next available zero crossing of the current[14]. There still might be a small amount of current flow to the fault through the snubber circuit. However the magnitude of this current is small and this can be easily interrupted by a mechanical switch that is always placed in series with the SSCB.

2.3.3 Solid state transfer switch (SSTS)

The schematic diagram of a solid state transfer switch (SSTS) is shown in figure 2.2. This device, which is also known as a static transfer switch (STS), is used to transfer power from the preferred feeder to the alternate feeder in case of voltage sag/swell or fault in the preferred feeder. The transfer switch would be used to protect the sensitive loads[13]. An SSTS contains two pairs of opposite poled switch. In this case the switch is made of thyristors. These switches are denoted by S_{w1} and S_{w2} in figure 2.2. Suppose the preferred feeder supplies the power to the load. This is done through the switch S_{w1} while the switch S_{w2} remains open.

If a sudden voltage sag occurs in the preferred feeder, the SSTS then closes the switch S_{w2} such that current starts flowing through the alternate feeder to the load. This switch S_{w1} is then switched off. This switching scheme is known as make before break (MBB) in which the switch S_{w1} is disconnected only after switch S_{w2} is connected.

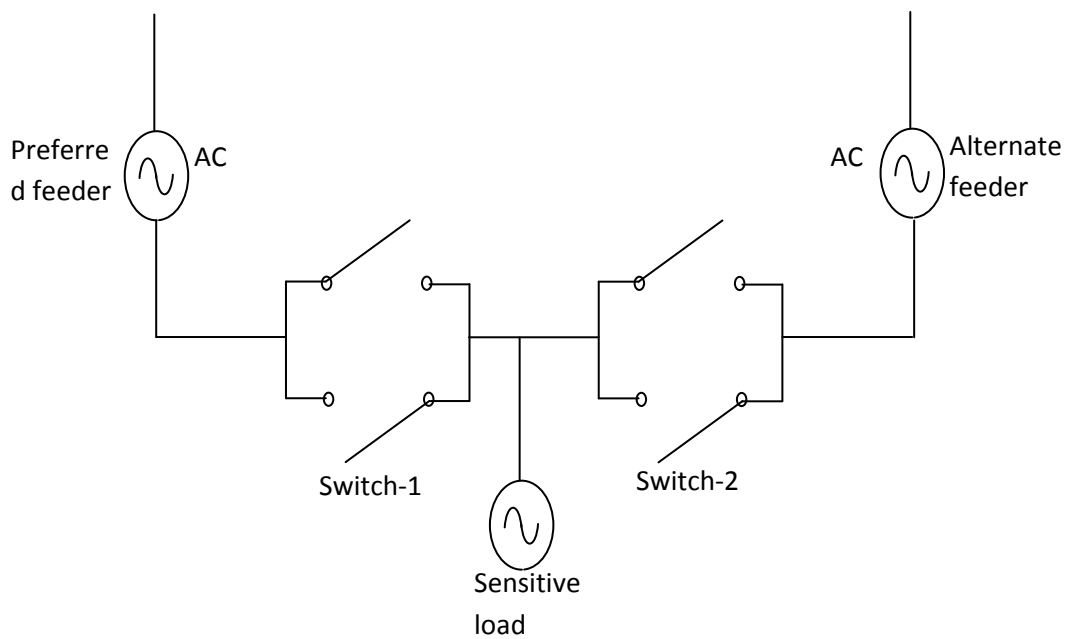

Fig.2.2. Schematic diagram of a static transfer switch

2.4 COMPENSATING DEVICES

The compensating devices either compensate a load, i.e. correct its power factor, unbalance etc., or improve the quality of the supplied voltage. These devices are either connected in shunt or in series or a combination of both.

2.4.1 Load compensation using DSTATCOM

The schematic diagram of a distribution system compensated by an ideal shunt compensator (DSTATCOM) is shown in fig. 2.3. In this it is assumed that the DSTATCOM is operating in current control mode. Therefore its ideal behaviour is represented by the current source I_f . It is assumed that Load-2 is reactive, non-linear and unbalanced. In the absence of the compensator, the current I_s flowing through the feeder will also be unbalanced and distorted and, as a consequence, so will be Bus-1 voltage.

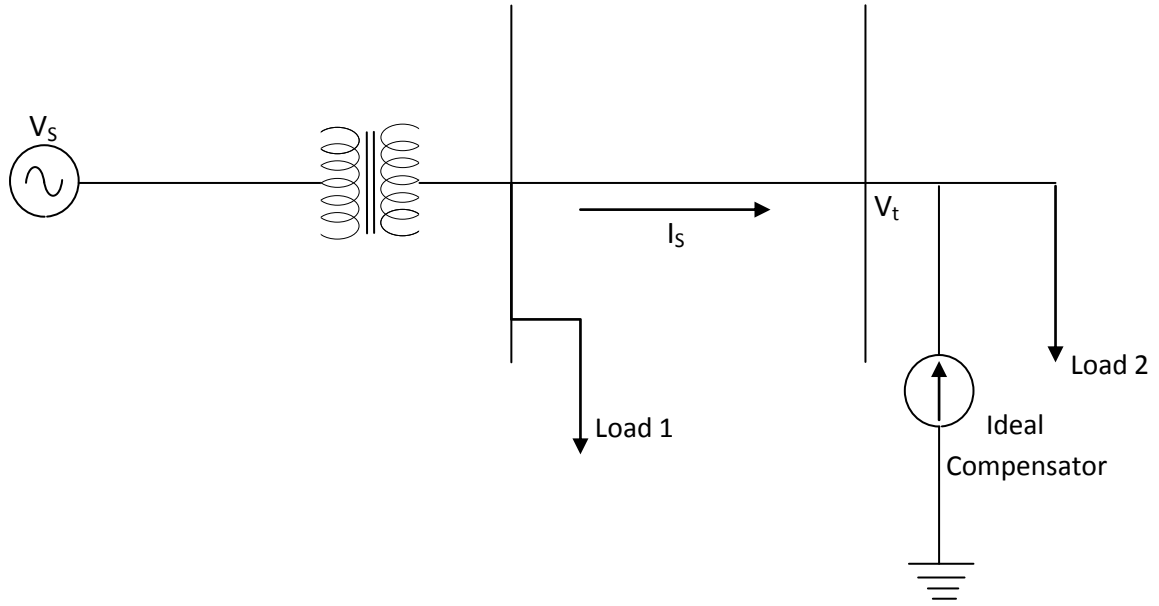

Fig.2.3. Schematic diagram of ideal load compensation

To alleviate this problem, the compensator must inject current such that the current I_s becomes fundamental and positive sequence [15]. In addition, the compensator can also force the current I_s to be in phase with the Bus-2 voltage. This fashion of operating the DSTATCOM is also called load compensation since in this connection the DSTATCOM is compensating the load current. From the utility point of view, it will look as if the compensated load is drawing a unity power factor, fundamental and strictly positive sequence current.

The point at which the compensator is connected is called the utility-customer point of common coupling (PCC). Denoting the load current by I_l the KCL at the PCC yields

$$i_s + i_f = i_l \Rightarrow i_s = i_l - i_f \quad (2.1)$$

The desired performance from the compensator is that it generates a current I_f such that it cancels the reactive component, harmonic component and unbalance of the load current.

2.4.2 Voltage Regulation using DSTATCOM

The schematic diagram of an ideal shunt compensator acting as a voltage regulator is shown in fig. 2.4 (a). In this the ideal compensator is represented by a voltage source and it is connected to the PCC. However it is rather difficult to realize this circuit and the alternate structure is shown in fig. 2.4 (b). It can be seen that it is the same structure used for load compensation in fig. 2.3. It has the advantage that the harmonics can be bypassed by the filter capacitor C.

The basic idea here is to inject the current i_d in such a way that the voltage v_t follows a specified reference[17]. The compensator must be operated such that it does not inject or absorb any real power in the steady state.

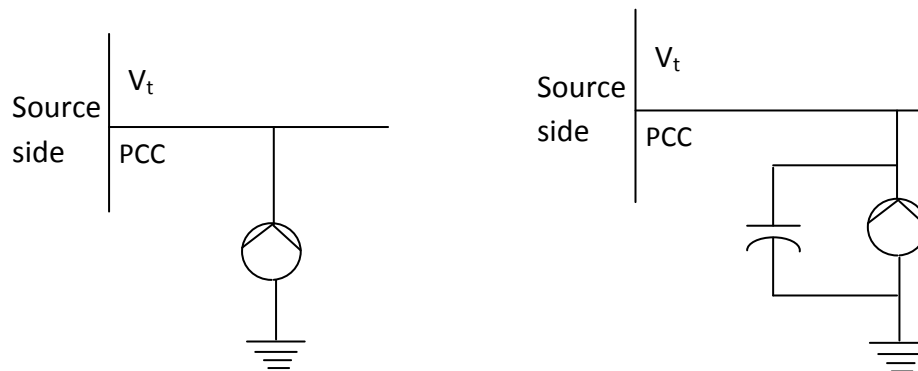

Fig. 2.4. (a) Ideal voltage controller and (b) its practical realization

2.4.3 Protecting Sensitive Loads using DVR

A dynamic voltage restorer (DVR) is used to protect sensitive loads from sag/swell or disturbances in the supply voltage. The schematic diagram of a sensitive load protected by an ideal series compensator (DVR) is shown in fig. 2.5. In this DVR is represented by an ideal voltage source that injects a voltage v_f in the direction shown. There are two different ways of constructing this device. The DVR can be constructed such that it is either capable or not capable of supplying or absorbing real power. The DVR voltage control is simple if it is capable of supplying or absorbing real power. Note from fig. 2.5 that

$$v_t = v_i + v_f \quad (2.2)$$

Where v_l is the load bus voltage. The DVR then can regulate the bus voltage to any arbitrary value by measuring the terminal voltage v_t and supplying the balance through v_f .

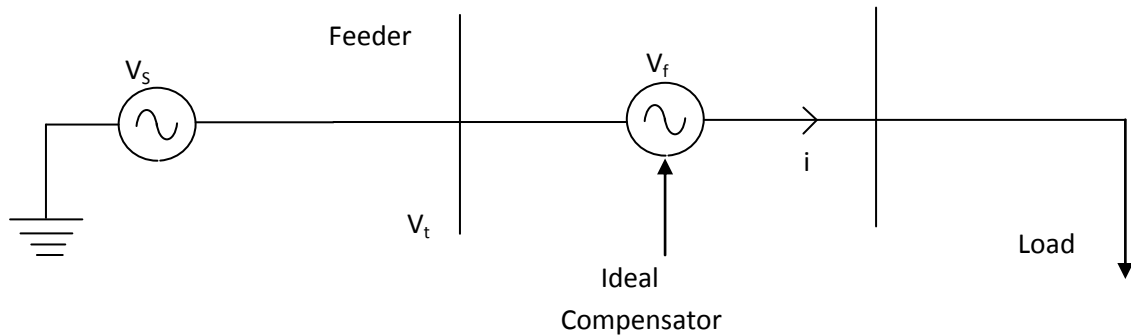

Fig. 2.5. Schematic diagram of a sensitive load protected by a DVR

The solution to this problem however is not as straight forward when the DVR is not capable of supplying or absorbing any real power in the steady state. It may instead have to supply or absorb real power during transients [19]. Note from the fig. 2.5 that the current through the line I_s is the same as the current through the line I_l . Also the phase angle difference between the load current I_l and the load voltage v_l must be in quadrature with the positive sequence fundamental frequency component with the load current I_l .

2.4.4 Unified Power Quality Conditioner (UPQC)

The schematic diagram of a unified power quality conditioner (UPQC) compensated distribution system is shown in fig. 2.6 (a). This is useful when both source and load are unbalanced and distorted. For example assume that the source voltage v_s is both unbalanced and distorted [20]. Also the load current i_l is also unbalanced and distorted. As a consequence the terminal voltage v_t and the source current i_s will also be unbalanced and distorted. Now suppose there are other customers connected to the load bus that draw purely balanced sinusoidal currents. Then both the source and load unbalance and distortion affect them. Again if there is a load bus

upstream from the point of common coupling, the customers on that bus will equally get affected. A UPQC can alleviate this problem.

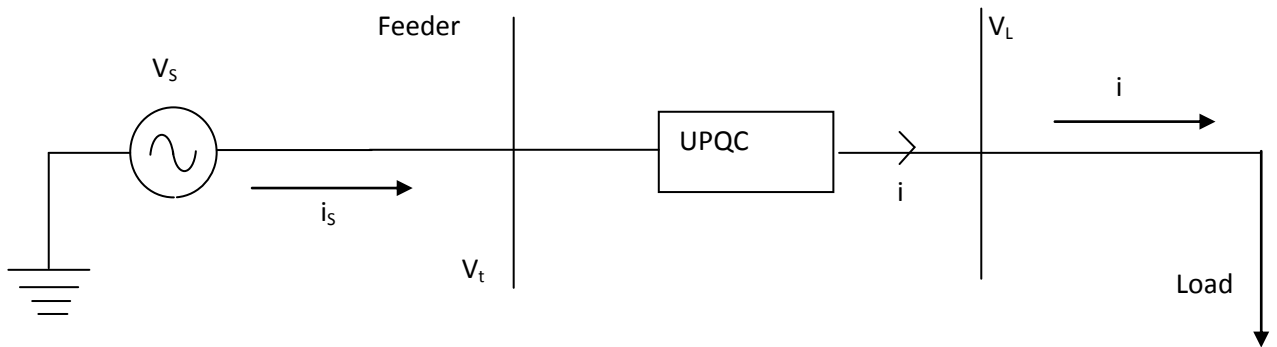

(a)

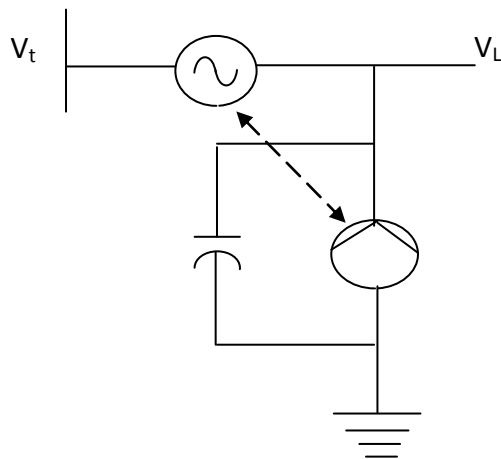

(b)

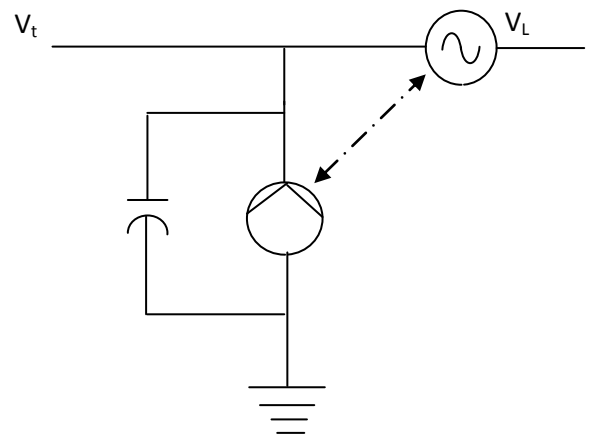

(c)

Fig. 2.6. (a) Schematic diagram of a UPQC compensated system, (b) & (c) two alternate connections

A UPQC combines a series and a shunt compensator together. It can therefore yield the benefits of both these devices. For example it can tightly regulate the load bus voltage v_l shown in fig. 2.6 (a). Therefore all loads including the unbalanced and non-linear load will have a supply voltage that is balanced and sinusoidal. The UPQC can also make the current drawn from the supply i_s balanced, sinusoidal and in phase with the terminal voltage (v_t). Therefore the voltage of any bus upstream from the PCC will

not be affected due to non-linear and unbalanced load[22]. However it would be impossible to correct the unbalance and distortion produced by the source voltage using this device. Therefore the upstream bus voltages will remain unbalanced and distorted.

There are two different ways of connecting a UPQC. These are shown in figure 2.6 (b) and (c). In the connection of fig. 2.6 (b) the series device is placed before the shunt device while it is placed after the shunt device in fig. 2.6 (c). The dotted lines in these figures indicates any energy exchange path between the devices. Usually the inverter realizing the series device is supplied by a dc capacitor. Similarly the shunt inverter is also supplied with a dc capacitor. In a UPQC both these inverters are supplied by a common dc capacitor. The energy exchange between the series and the shunt device takes place through this common dc capacitor.

UNIFIED POWER QUALITY CONDITIONER

3.1 INTRODUCTION

Most large power and industrial loads are three phase in nature. The production industries like automobile manufacturing plants, paper mill, textile fibres, medicines, food production and processing, etc. have critical loads, which are sensitive to voltage variations and should be interested in a multi-purpose PQ compensating equipment. These loads require to avoid punitive tariff due to low power factor and THD in addition to their protection from supply voltage variation. Hence, measures are taken to save them from production loss and also to maintain quality control.

This aspect brings out the importance of the investigations on three phase Unified Power Quality Conditioner (UPQC), which takes care of supply voltage sag in addition to compensating load harmonics and reactive current.

The UPFC is employed in the power transmission system to perform shunt and series compensation at the same time. Since the power transmission line generally operates in balanced distortion free environment, it differs from the UPQC in terms of functional motives in this regard. Primary function of the UPFC is to deal with the control of the reactive as well as active power flow and monitor the terminal voltage at fundamental frequency only. On the other hand, the power distribution system may contain imbalance, distortion and even dc components. Therefore, unlike UPFC, UPQC deals with the harmonic part of the current and voltages as well, and is installed on the distribution site. The general unified power quality conditioner has the following functions shared by the series active filter and the shunt active filter. The functions being performed with the series active filter are the following.

- 1) Harmonic isolation between the transmission system and the distribution system.
- 2) Voltage regulation at the PCC.
- 3) Dynamic restoration of PCC voltage by compensating voltage sag.
- 4) Low frequency voltage flicker compensation.

- 5) Load voltage balancing by neutralizing the non-positive voltage sequence components.

The functions being performed by the shunt active filter are as following.

- 1) Reactive power compensation.
- 2) Harmonic current elimination from supply line.
- 3) Negative-sequence current compensation.
- 4) DC link voltage regulation between both active filters.

These functions are traditionally defined in the literature. But depending upon the control algorithm and system requirement, some of the functions can be exchanged between the two inverters.

3.2 CONVENTIONAL CLASSIFICATION OF UPQC

The conventional UPQC can be broadly classified with respect to angle of voltage injection by the DVR in two categories namely UPQC-Q and UPQC-P. The schematic block diagram of (left shunt) UPQC is shown in Fig. 3.1.

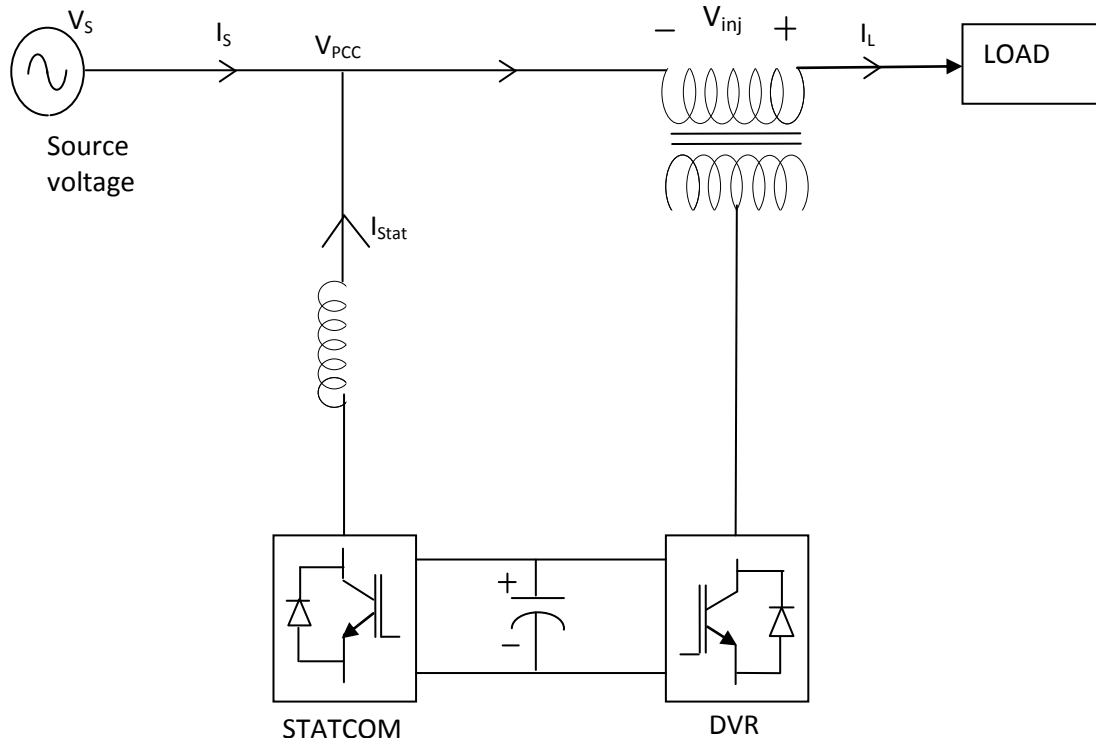

Fig.3.1. Left shunt UPQC

The UPQC consists of two 3-phase voltage source inverters connected in cascade through a common dc link capacitor. The DVR and the STATCOM are series and shunt connected voltage source inverters (VSIs) respectively. The STATCOM has three objectives given as follows.

- 1) Elimination of the harmonics from the supply current. This helps in making the supply current sinusoidal.
- 2) Compensation of the reactive power demand of the load. Once the harmonics are removed from the supply current, unity power factor operation can be achieved by supplying reactive power of the load locally.
- 3) Regulation of the dc link voltage. This is very important function for both shunt and series active filters. This enables the inverter operation of both converters. When voltage sag occurs, the DVR injects a voltage at a particular angle with the supply voltage such that the voltage at the point of common coupling (PCC) is always maintained at the desired magnitude.

For UPQC-Q angle of injection is 90° leading the post sag source voltage whereas in UPQC-P voltage is injected in phase with the post sag source voltage.

For UPQC-P, the operation of the STATCOM and DVR remains the same, except the angle of voltage injection by the DVR. In UPQC-P, DVR injects voltage ‘in phase’ with the post sag voltage such that the resultant voltage remains ‘in phase’ with the post sag voltage.

3.3 RELATIVE POSITIONS OF SHUNT AND SERIES ACTIVE FILTERS IN UPQC

Fig. 3.2 shows the two possible topologies of UPQC related to position of the series and shunt active filter [29].

There is a notable difference in the installation point of the shunt-active filter between fig 3.2 ‘right shunt UPQC’ and fig 3.3 ‘left shunt UPQC’. Salient comparing characteristics of these two topologies are as followed:

- 1) The ‘right shunt UPQC’ can be operated in a zero power injection/absorption mode, while the ‘left shunt UPQC’ cannot operate in this mode.

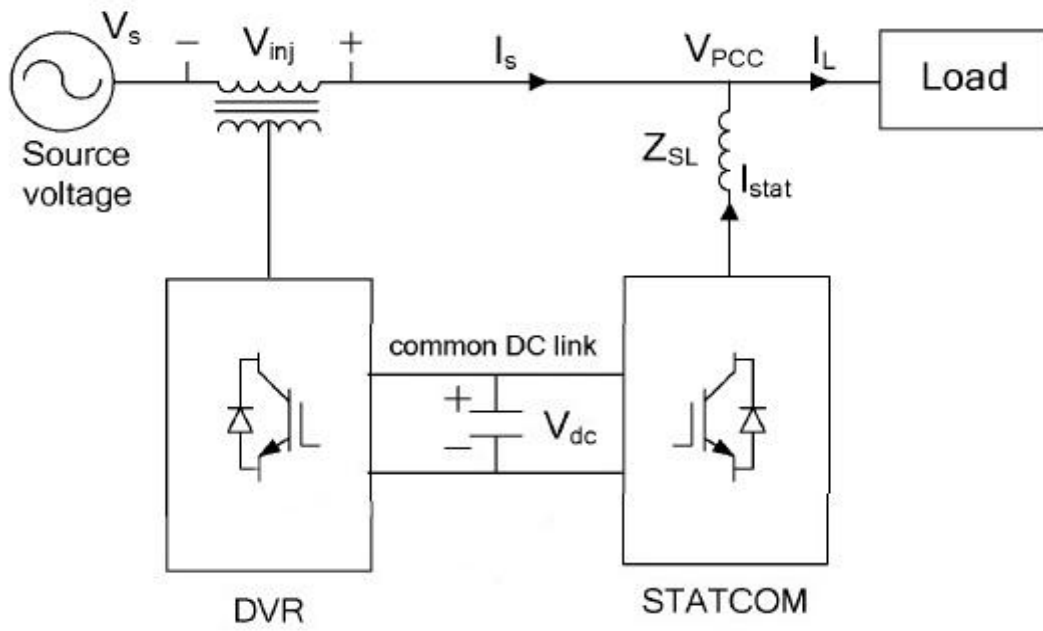

(a) Right Shunt UPQC

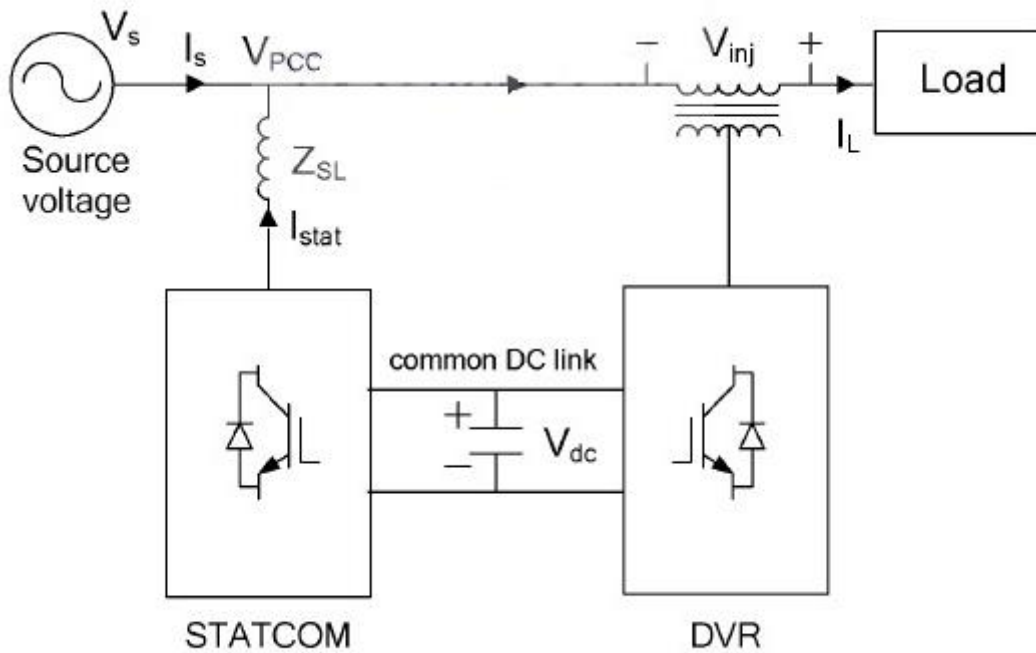

(b) Left shunt UPQC

Fig.3.2. Types of topologies of UPQC

- 2) The 'right shunt UPQC' can make the power factor unity at the load end terminal, while the power factor at the load terminal depends on the load for the left shunt UPQC.
- 3) The shunt compensator in the 'right shunt UPQC' can supply the entire requirement of the reactive power by the load whereas the shunt compensator in the 'left shunt UPQC' can only supply the mean of the load reactive power.

Thus, it can be concluded that overall characteristics of the right shunt UPQC are better than the left shunt UPQC.

3.4 POWER CIRCUIT CONFIGURATION AND OPERATING PRINCIPLE

The typical line diagram of a UPQC system consisting of two inverters connected in cascade along with an energy storage system is as shown in Fig. 3.1. The scheme can be implemented for a three phase three wire system [30]. Ideally each phase would represent a similar circuit as in the single phase case; however, some points of difference arise by virtue of the interdependence of the three phases. Although individual phase handle VAR it is well known that in a sinusoidal balanced three phase system average as well as instantaneous VAR sum up to zero. Therefore, in the ideal case when the shunt converter is used to compensate for the fundamental active power only, the dc link need not carry any current at all. But in reality, DC link capacitor carries the ripple current which is largely dependent upon the switching frequency of the converter. The dc link voltage has to be higher than the peak of the line to line voltage of the supply in order to achieve effective current control. The other criterion of choice of dc link voltage depends upon the voltage sag to be mitigated through the series converter. The higher of the two voltages is selected as the choice of dc link voltage.

The functions of shunt and series compensators remain the same as in the single phase case.

Let us now discuss about the active power filters as they essentially are the building blocks of any modern power quality conditioning system.

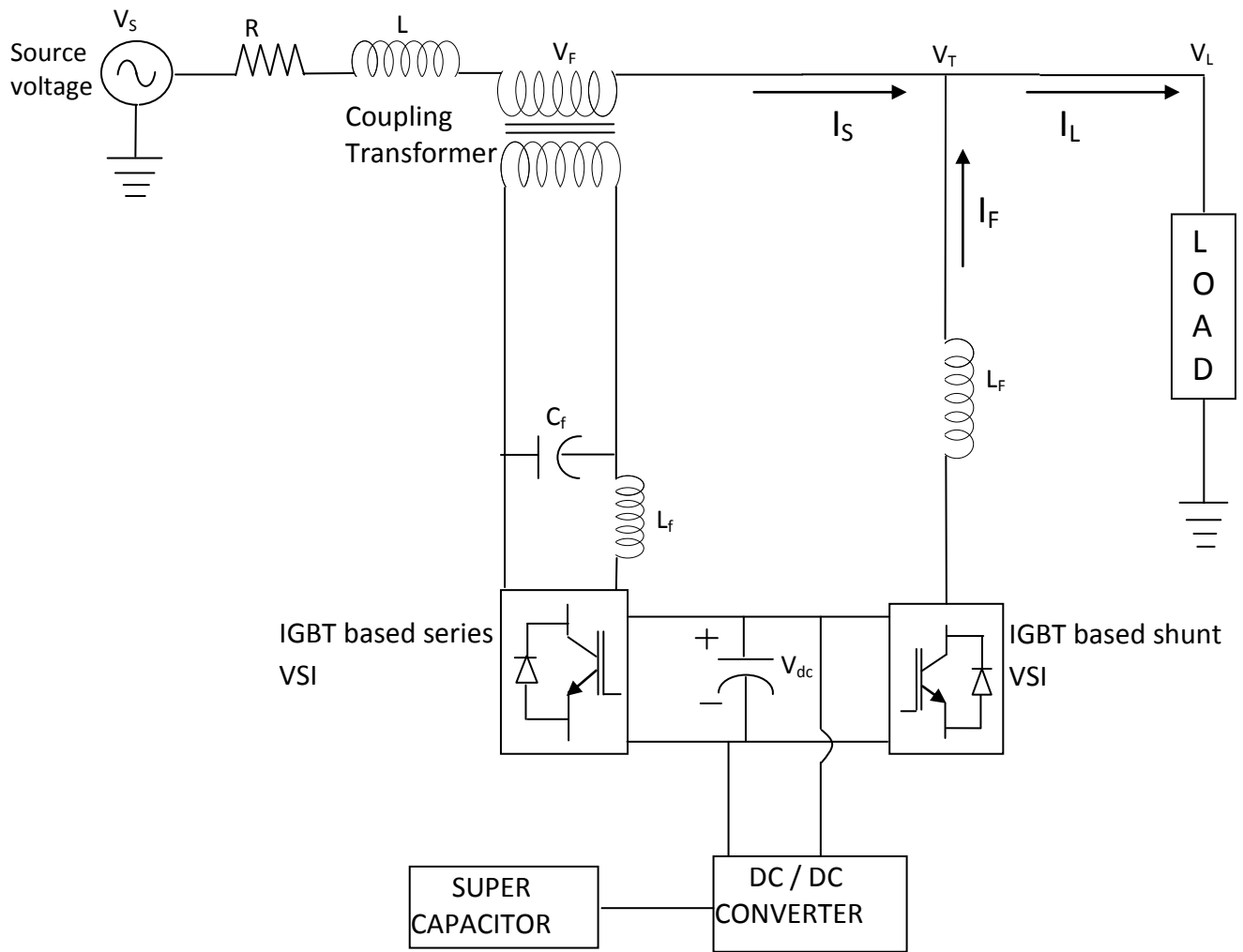

Fig.3.3. A typical UPQC system connected with energy storage

3.5 CONCLUSION

This chapter proposes a multipurpose power conditioning equipment, named Unified Power Quality Conditioner (UPQC), for a power system having the following facilities:

1. The Unified Power Quality Conditioner (UPQC) maintains load end voltage at the rated value in case of supply voltage sag.
2. It eliminates the harmonics in the supply current, hence improves utility current quality for nonlinear loads.

3. It provides the VAR requirement of the load, such that the supply voltage and current are always in phase. So, no additional power factor correction equipment is necessary.

The use of UPQC, therefore, has a great potential for the improvement of power quality in both three phase and single phase systems.

CONTROL STRATEGY

4.1 INTRODUCTON

When a number of non-linear loads are connected to PCC, then supply waveform gets distorted. Since non-linear loads are very sensitive loads so protection against harmonics must be provided. Active filters are used to protect these loads. Designing filter for every load i.e. for every end user will be very tedious and costly. To avoid this problems series APF is connected at PCC[35]. The series APF is connected at PCC by use of injection CTs and shunt APF is connected in parallel.

4.2 PRINCIPLE OF OPERATION

Figure 4.1 show the topology used to eliminate the load voltage harmonics with active filter in the case of voltage source harmonic loads. L_s represent the voltage source inner inductance. In the dc side, the inverter has been connected to two sources whose values are constant. In the AC side, a filter has been connected to eliminate the high frequency components. This filter is composed of an inductance L_R and a capacitor C_R . The transformers connect the compensator to the system

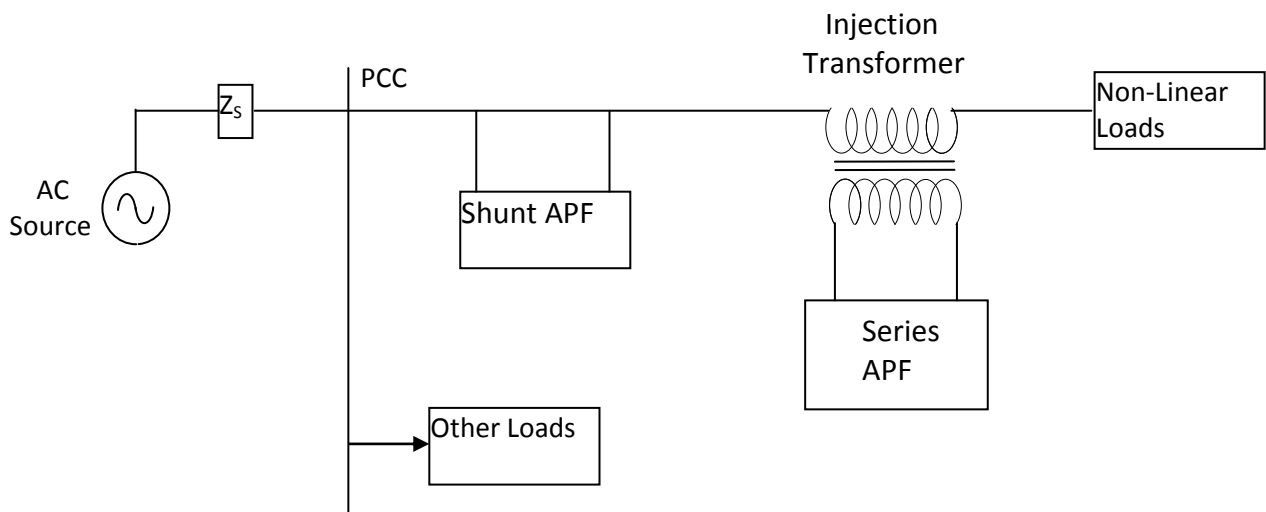

Fig.4.1. Connection diagram of UPQC

It is defined considering harmonics different of the fundamental one. So, the voltage source does not present harmonic components and the only voltage harmonics present in the system are the produced by the load. The load has been modelled by means of a voltage source, VLH. In figure 4.2, Z_s represents the source impedance corresponding to the harmonic frequency. The filter is modelled by a controlled source which generates the voltage corresponding to the chosen strategy. Since an ideal point of view, the load has been represented by a voltage source whose frequency corresponds to the harmonic analysed.

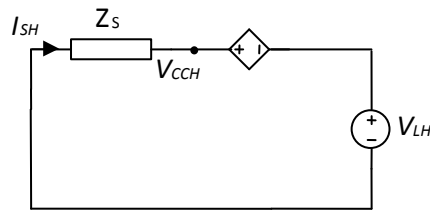

Fig.4.2. Equivalent single-phase circuit corresponding to harmonic

The series active filters control has been carried out by means of following compensation strategy-

Control strategy which measures the load voltage to make that the APF generates a voltage with that same harmonic content and the opposite sign.

$$V_{ch} = K_v \cdot V_{lh} \quad (4.1)$$

Nevertheless, the measurement of the load voltage harmonic generally depends on the instrumentation sensibility k_v . So, the voltage supplied by the APF applying this strategy can be expressed as follows:

$$V_{ch} = K_v \cdot V_{lh} \quad (4.2)$$

According to this expression, the voltage in the point of common coupling is, for a specific harmonic $h \in H$:

$$V_{ch} = V_{lh} (1 - K_v) \quad (4.3)$$

4.3 REFERENCE SIGNAL GENERATION

The Reference signal generation is done by using UTT theory[25]. The Strategy employed for the Series and Shunt active filters used is same. The equations showing the generation of the reference signals are given below-

4.3.1 Series Active filter

The extraction of three-phase voltage reference signal for series APF is based on Unit Vector Template Generation, achieved with the help of PLL. These Unit Vector Templates are multiplied with the desirable peak amplitude (V_{tmn}) of loadvoltage to obtained reference load voltages denoted by V_{lar} , V_{lbr} and V_{lcr} , for phase a, b and c respectively and are given by-

$$V_{lar} = V_{tmn} \cdot u_a \quad (4.4)$$

$$V_{lbr} = V_{tmn} \cdot u_b \quad (4.5)$$

$$V_{lcr} = V_{tmn} \cdot u_c \quad (4.6)$$

Where u_a , u_b and u_c are unit vector templates which are in phase with supply voltage and are given by-

$$u_a = \sin(\omega t) \quad (4.7)$$

$$u_b = \sin(\omega t + 120) \quad (4.8)$$

$$u_c = \sin(\omega t - 120) \quad (4.9)$$

4.3.2 Shunt Active Filter

Unit vector template generation theory is again used here. These Unit Vector Templates are multiplied with the desirable peak amplitude (I_{tmn}) to obtain the reference currents denoted by I_{lar} , I_{lbr} and I_{lcr} , for phase a, b and c respectively and are given by-

$$I_{lar} = I_{tmn} \cdot i_a \quad (4.10)$$

$$I_{lbr} = I_{tmn} \cdot i_b \quad (4.11)$$

$$I_{lcr} = I_{mn} \cdot i_c \quad (4.12)$$

Where i_a , i_b and i_c are unit vector templates which are in phase with supply current and are given by-

$$i_a = \sin(\omega t) \quad (4.13)$$

$$i_b = \sin(\omega t + 120) \quad (4.14)$$

$$i_c = \sin(\omega t - 120) \quad (4.15)$$

4.4 HYSTERESIS CURRENT CONTROL METHOD

In this method, the actual current continually tracks the command current within a hysteresis-band[31]. Pre-set upper and lower tolerance limits are compared to the extracted error signal. As long as the error is within the tolerance band, no switching action is taken. Switching occurs whenever the error leaves the tolerance band. The hysteresis current control is the fastest method with minimum hardware and software.

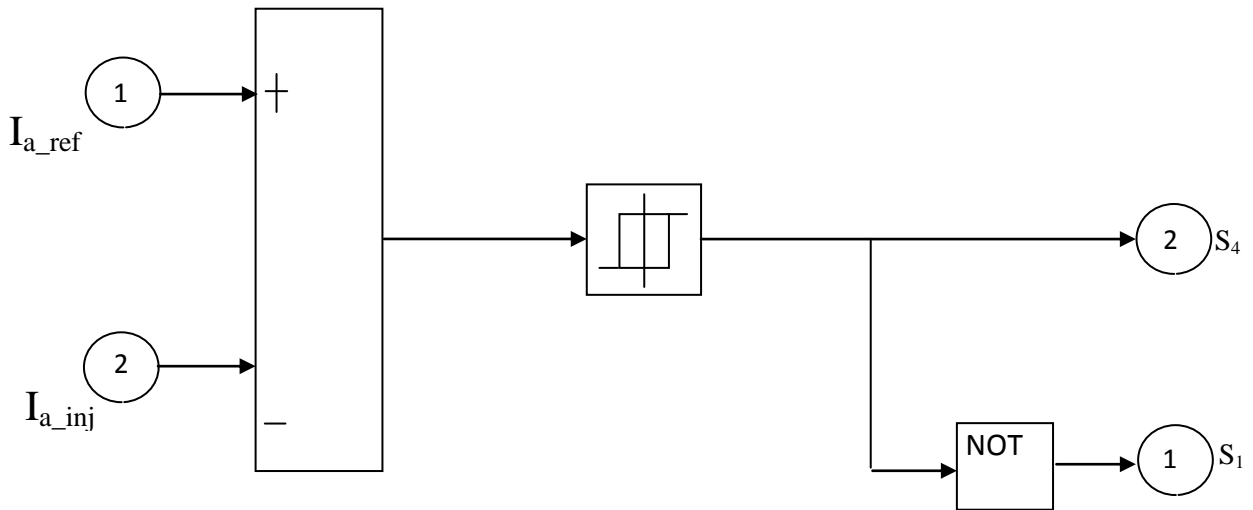

Fig.4.3. Simulation scheme for hysteresis current control

In the project we have used the hysteresis current control; it's very commonly used because of its simplicity of implementation and its robustness. This strategy provides satisfactory control of current without requiring extensive knowledge of

control system model or its parameters. Figure 4.2 presents the principle of command that this is mainly to maintain each of the currents generated by the APF's in a band surrounding the reference currents [26].

Hysteresis-band PWM is basically an instantaneous feedback control method of PWM where the actual signal continually tracks the command signal within a hysteresis band.

Each violation of this band gives an order of commutation as the figure 4.3 shows

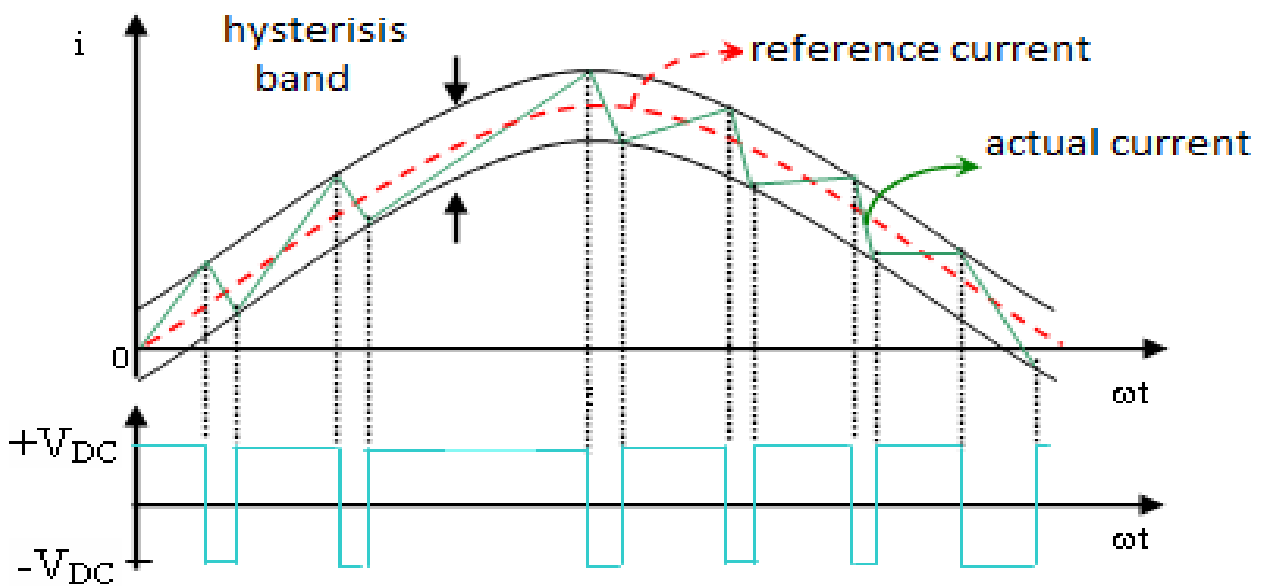

Fig.4.4. Pulse generation by hysteresis band control

With the hysteresis control, limit bands are set on either side of a signal representing the desired output waveform. The inverter switches are operated as the generated signals within limits. Hysteresis-band PWM is basically an instantaneous feedback control method of PWM where the actual signal continually tracks the command signal within a hysteresis band. The rate of change of inductor current is then given by-

$$\frac{di}{dt} = \frac{V_c \pm V_m \sin(\omega t)}{L_f} \quad (4.16)$$

Making assumption that the ac supply does not change during a cycle of switch operations, the time taken t_m to cross a dead band is-

$$t_m = \frac{L\Delta I}{V_c - V_s \sin(\omega t)} \quad (4.17)$$

The switching frequency f_{sw} is, therefore variable. Combining above two equations (4.16) and (4.17) to obtain the switching period, and inverting, gives-

$$f_{sw} = \frac{V_c^2 - V_s^2 \sin^2(\omega t)}{2L\Delta I V_c} \quad (4.18)$$

4.5 DC LINK CAPACITOR

The dc side capacitor serves two main purposes:

1. It maintains a dc voltage with a small ripple in steady state.
2. It serves as an energy storage element to supply the real power difference between load and source during the transient period. In the steady-state, the real power supplied by the source should be equal to the real power demand of the load plus a small power to compensate for the losses in the active filter. Thus, dc capacitor voltage can be maintained at a reference value. However during the change in load conditions the real power balance between the source and the load will be disturbed. This real power difference is to be compensated by the dc capacitor. This changes the dc capacitor voltage away from the reference voltage. In order to keep the satisfactory operation of the active filter, the peak value of the reference current must be adjusted to change proportionally the real power drawn from the source. This real power charged or discharged by the capacitor compensates for the real power consumed by the load. If the dc capacitor voltage is recovered and attains the reference voltage, the real power supplied by the source is supposed to equal that consumed by the load again.

RESULTS AND DISCUSSIONS

5.1 INTRODUCTION

The main objectives of our project can be summarized as follows:

1. Reduction in the harmonics in the voltage at PCC.
2. Reduction in the harmonics in the source current.
3. Improvement of the power factor of the whole system.

5.2 SIMULATION PARAMETERS

In this project, rectifier fed resistive and rectifier fed R-L load are used as non-linear loads. The value of parameters such as supply system, source impedance, rectifier fed resistive load, rectifier fed R-L load, series active power filter, shunt active power filter, injection transformer, etc. are given in the table 5.1.

S. No.	System Parameters	Value of Parameters.
1.	Supply System	240V, 50Hz, 3-phase supply.
2.	Source Impedance	$R_s = 0.2\Omega$, $L_s = 1\text{mH}$
3.	Rectifier fed resistive load	$R = 30\Omega$
4.	Rectifier fed RL load	$R = 100\Omega$, $L = 100\text{mH}$
5.	Series Active Power Filter	$V_{ref} = 240\text{V}$, $L = 1\text{mH}$, $R = 0.4\Omega$
6.	Injection Transformer Rating	1KVA, 50Hz, 240/240V.
7.	RC filter parameters	$R = 20\Omega$, $C = 150\mu\text{F}$
8.	Shunt Active Power Filter	$I_{ref} = 30\text{A}$, $L = 1\text{mH}$, $R = 3\Omega$

Table 5.1 System Parameters

5.3 SIMULATION WITHOUT UPQC

The simulation circuit and waveforms are given below:

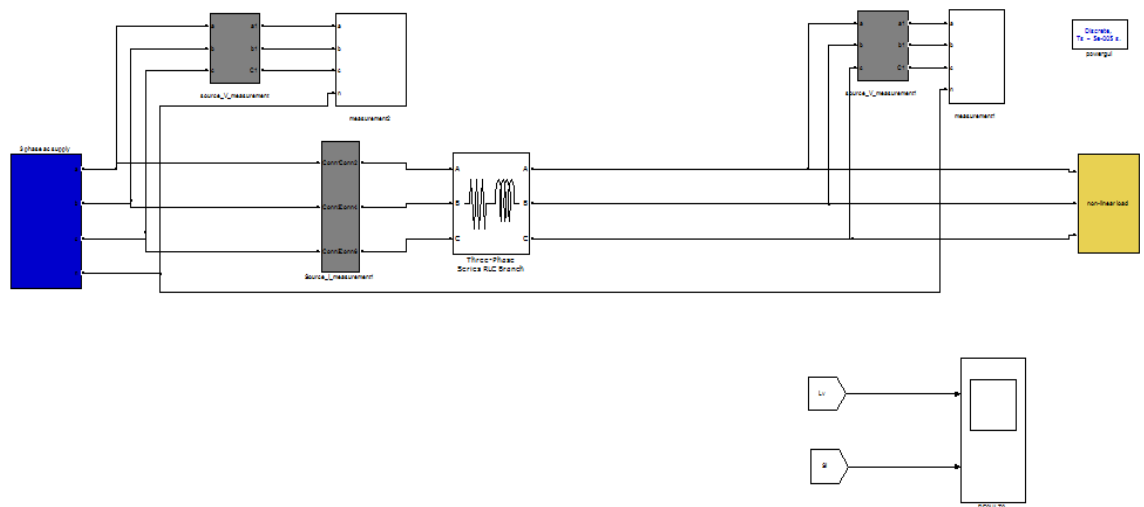

Fig 5.1 Simulation model of rectifier fed RL load connected at PCC without UPQC.

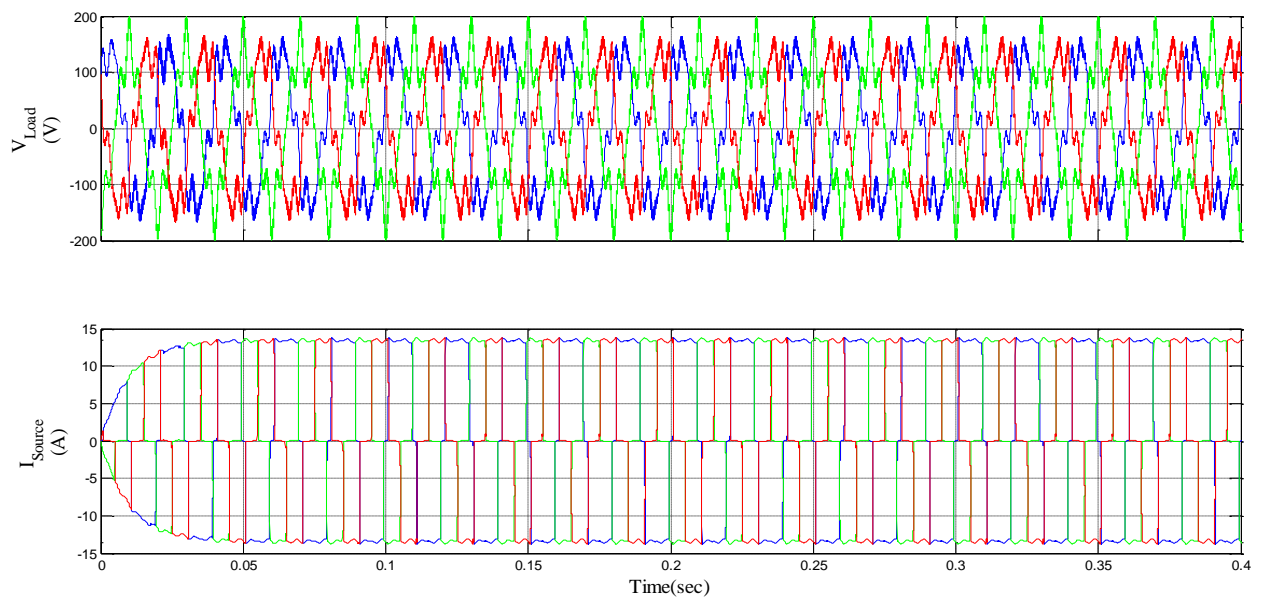

Fig. 5.2. Load Voltage and Source Current without UPQC

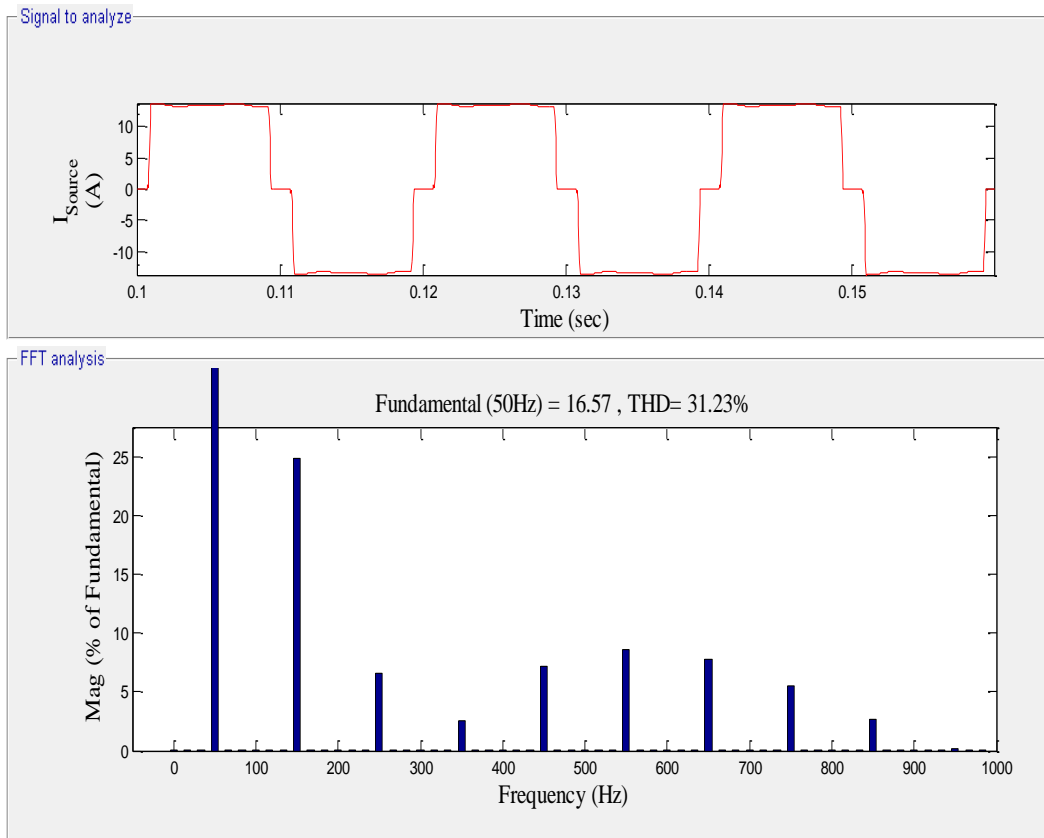

Fig.5.3. THD in source current without UPQC.

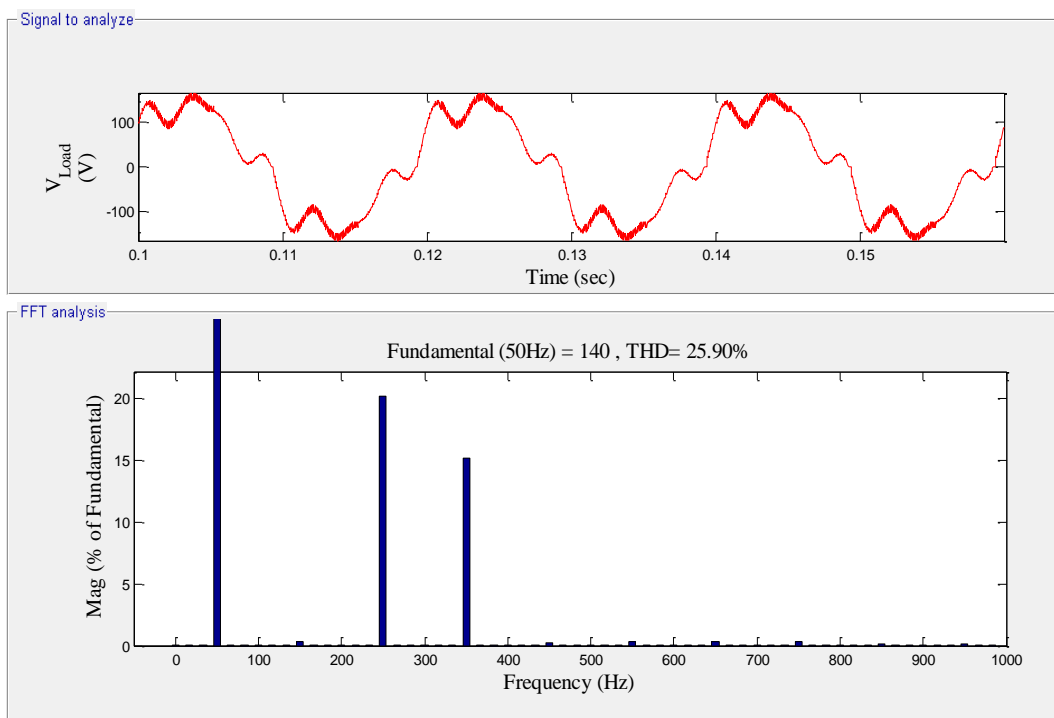

Fig. 5.4. THD in Load voltage without UPQC

5.4 SIMULATION WITH UPQC

Simulation model of circuit using unified power quality conditioner is given below along with their corresponding waveforms of voltage at PCC and source current. In this project, hysteresis band gap controllers and UTT generation theory are used for both series and shunt active power filters. To show the clear operation of UPQC, both Series active power filter and shunt active power filter are put in operation at $t = 0.2s$ so that the distorted current and voltage waveform can be shown in a single diagram along with compensated voltage and current waveforms. To show the improvement in power quality the improvement in power factor of the system has been calculated and the corresponding increase in power factor is presented here.

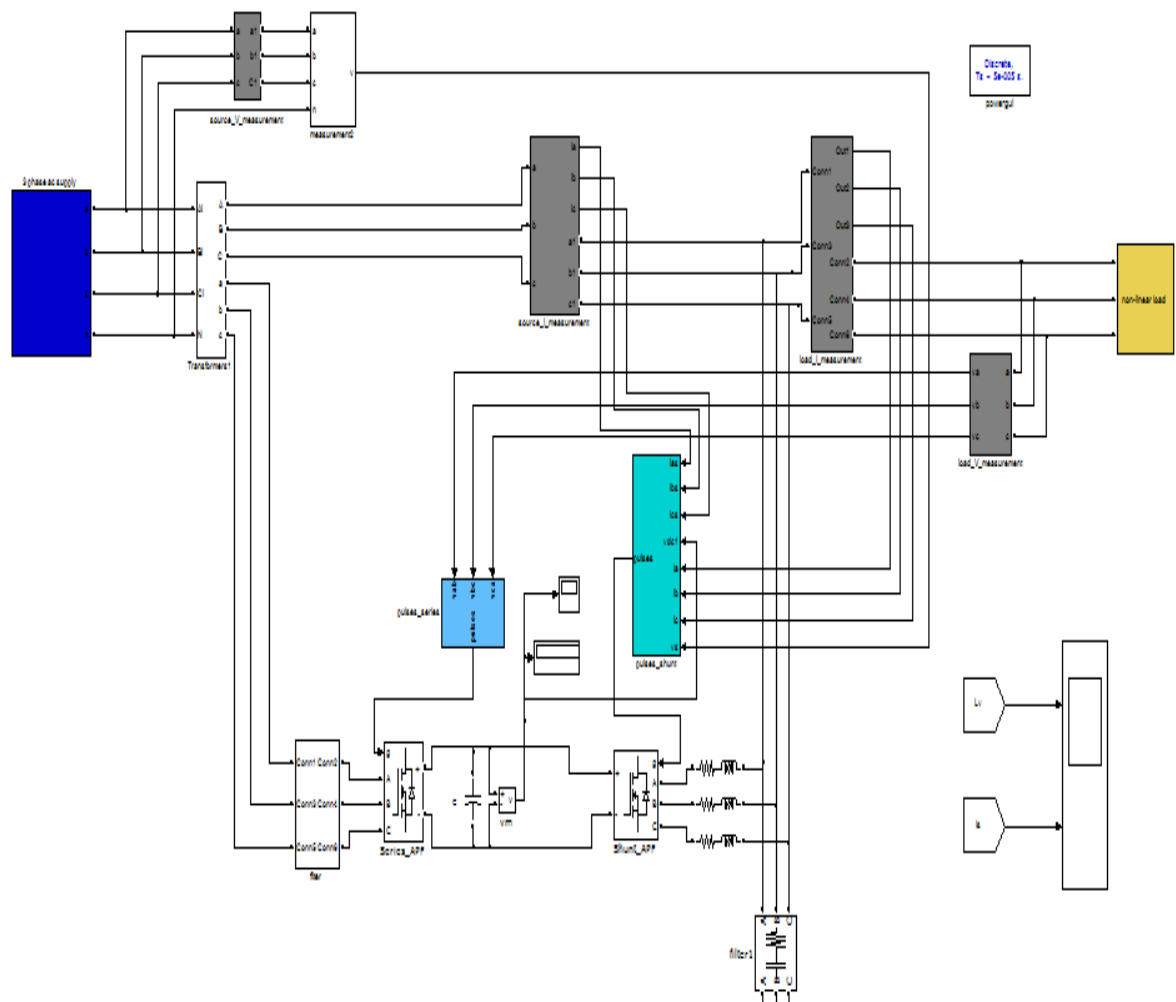

Fig. 5.5. Simulation model of circuit with rectifier fed RL load using UPQC.

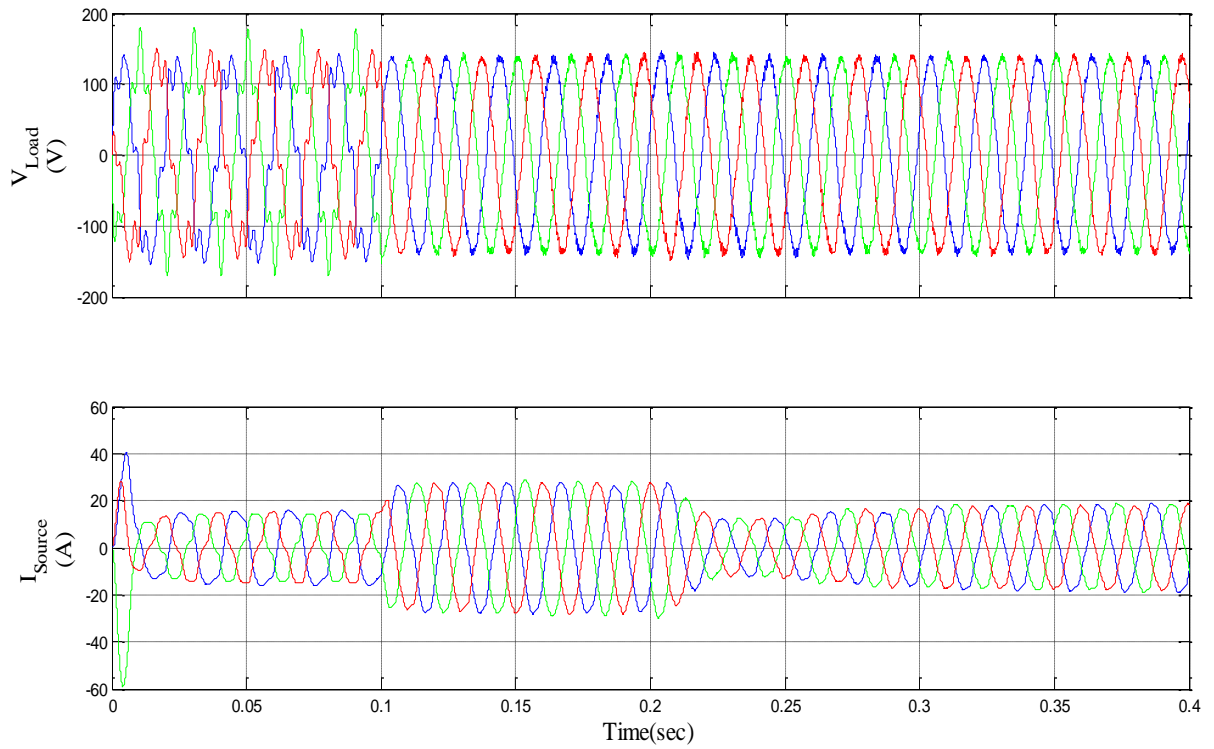

Fig. 5.6. Load Voltage and Source Current waveform with UPQC

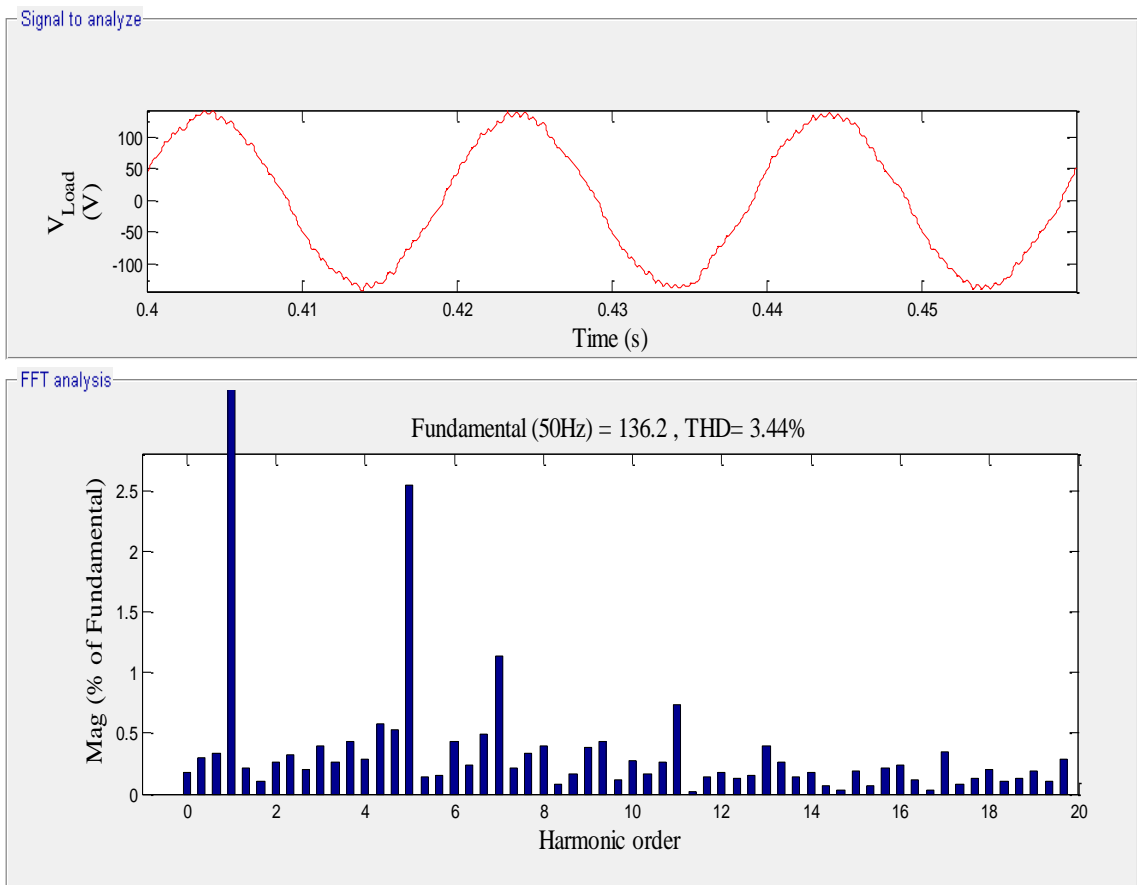

Fig. 5.7. THD in Load Voltage using UPQC.

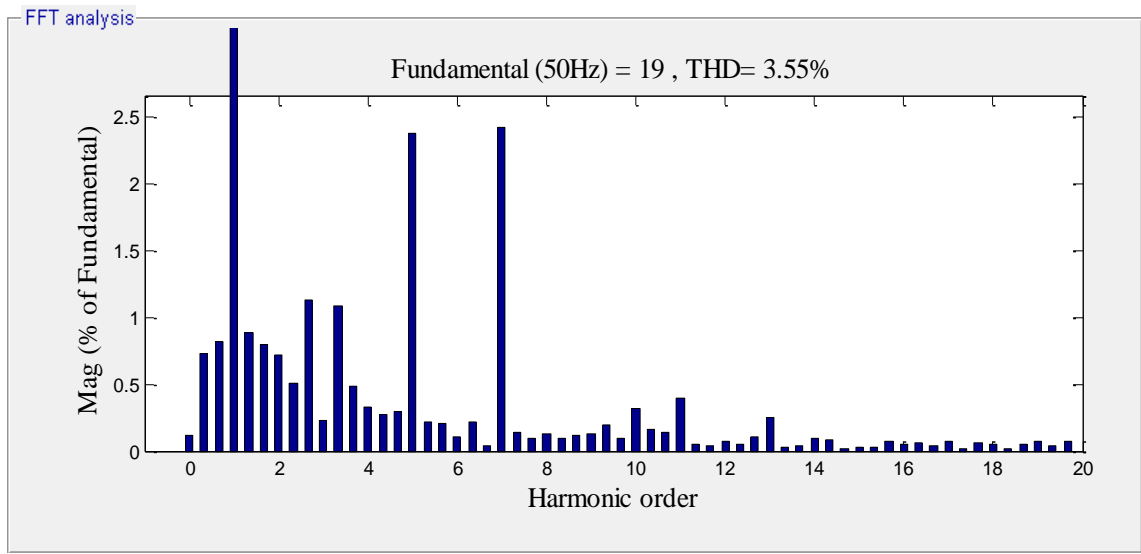
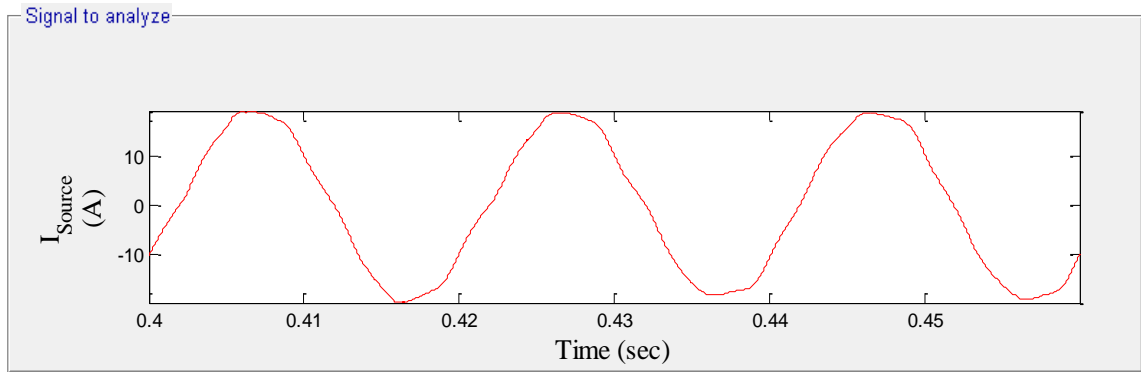

Fig. 5.8. THD in source current using UPQC.

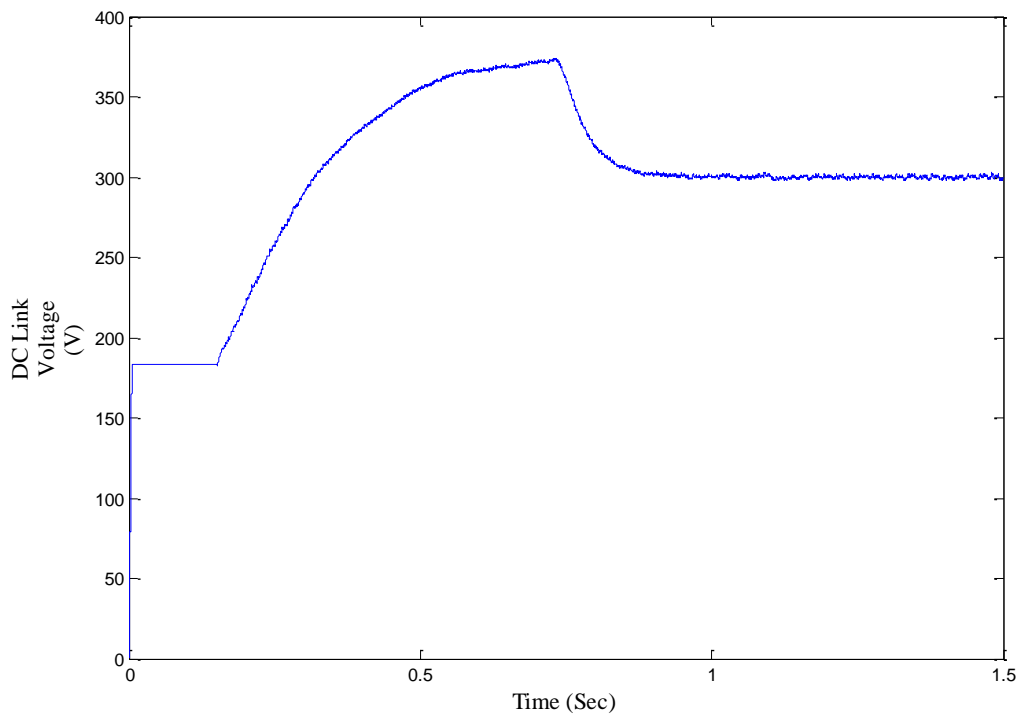

Fig. 5.9. DC Link Voltage.

5.5 SIMULATION RESULT ANALYSIS AND DISCUSSION

The THD in voltage and current is calculated using Fast Fourier Transform. In case of non-linear loads the power factor depends on distortion factor along with displacement factor and is given by:

$$P.F = \text{Displacement Factor} \times \text{Distortion Factor}$$

If the distortion in source voltage is negligible then the formula used for calculating power factor is given below:

$$P.F. = \frac{1}{\sqrt{(1 + THD^2)}}$$

The simulation result without and with UPQC for above model are shown in the following table:

S. No.	Without UPQC	With UPQC
1.	THD in source current	THD in source current
	31.23%	3.55%
2.	THD in voltage at PCC	THD in voltage at PCC
	25.90%	3.44%

Table 5.2 Simulation result

From table 5.2 it can be seen that the use of UPQC has considerably reduced the THD in source current from more than 30% to only about 3.55% which is well within the IEEE tolerance limits of 5.0%. The THD in voltage waveform has also reduced from about 25% to about 3.44% which also is within the IEEE tolerance limits.

Thus, the overall quality of the power has considerably improved by employing UPQC.

5.6 PERFORMANCE ANALYSIS

It can be seen that all the objectives of the project have been fulfilled. The summary of the project results can be summarized in a tabular form as follows:

S. No.	Performance parameters	Without UPQC	With UPQC
1.	Source current THD	Very High	Very Low (within IEEE-519 tolerance limits)
2.	PCC voltage THD	High	Very low (within IEEE-519 tolerance limits)

Table 5.3 Performance analysis of UPQC

CONCLUSIONS AND FUTURE SCOPE

6.1 CONCLUSIONS

The UPQC has become the most important technique for improvement of power quality in electrical power distribution systems. In this project, a model for 3-phase UPQC for non-linear loads connected at PCC is simulated using MATLAB/ Simulink software package for the reduction of harmonics in voltage at PCC. The conclusions for project are such as:

- Performance of UPQC is analysed using Hysteresis current control technique for minimising harmonic in voltage at PCC.
- The performance of UPQC is verified with simulation results. From the results, it is clear that the harmonics have reduced by nearly 7-8 times.
- The THD in voltage at PCC without using UPQC was about 25.90%.
- The THD in voltage at PCC reduced to about 3.55% after using the UPQC.
- The THD in source current reduced to about 3.44% from more than 25%.

6.2 SCOPE FOR FUTURE WORK

- The hardware implementation of UPQC can be done with Hysteresis current control technique.
- The UPQC can be used efficiently to mitigate almost all type of power quality problems viz. power factor improvement, voltage sag and swell, transient overvoltage, voltage regulation, harmonic reduction in current and voltage signals, etc.
- Artificial Neural Network based SVPWM control technique can be used in place of Hysteresis current control technique.

REFERENCES

- [1] Yash Pal and A. Swaroop, "Performance of UPQC for power quality improvement", 978-1-4244-7781-4/10 IEEE.
- [2] Vikash Anand and Dr. S.K. Shrivastava, "Simulation And Performance Investigation Of Series Active Power Filter Using Hysteresis Current Control Method"
- [3] B.Singh and V.Verma, "A New Control Scheme of Series Active Filter for Varying Rectifier Loads".
- [4] MoinuddinK.Sayed and Dr. BV Shanker Ram, "Instantaneous power theory based active power filter: a MATLAB/ Simulink approach", 2005-2008 JATIT.
- [5] Norman Mariun, AhsanulAlam, SenamMehmod and HashimHisram, "Review of control strategy for power quality conditioner", National Power & Energy Conerence (PECon) 2004 Proceedings, Kuala Lunipur, Malaysia.
- [6] Juan W. Dixon and Luis A. Moran, "A series active power filter based on a sinusoidal current-controlled voltage-source inverter", IEEE Transactions On Industrial Electronics, Vol. 44, No. 5, October 1997.
- [7] L. H. Tey, andP. L. So, "System Harmonics Compensation using PWM Voltage Source Inverter-Based Active Filters", PPT 2001 IEEE Porto Power Tech Conference 10th-13th September, Porto, Portugal.
- [8] Hui Yan, Jun Li, and Guoqing Tang, "Study of Series Power Quality Compensator with Feedback Control Strategy for Inverters", 2004 IEEE International Conference on Electric Utility Deregulation, Restructuring and Power Technologies (DRPTZOM) April 2004 Hong Kong.
- [9] Enio R. Ribeiro and Ivo Barbi, "Harmonic Voltage Reduction Using a Series Active Filter Under Different Load Conditions", IEEE Transactions On Power Electronics, Vol. 21, No. 5, September 2006.
- [10] P. Salmeron and S. P. Litran, "Improvement of the Electric Power Quality Using Series Active and Shunt Passive Filters", IEEE Transactions On Power Delivery, Vol. 25, No. 2, April 2010.
- [11] S.P. Litan, P. Salmeron, R.S.Herrera, J.R. Vazquez, "Control of Series Active Filter by state feedback" ,Comision IEE proc.Electr.Power Appl., Vol, 151,no.3, May 2004, pp. 276-282

- [12] T. Ueda and M. Morita' SOLID-STATE CURRENT LIMITER FOR POWER DISTRIBUTION SYSTEM. IEEE Transactions on Power Delivery, Vol. 8, No. 4, October 1993
- [13] K.CHAN G, A. KARA and KIEBOOM Power Quality Improvement with Solid State Transfer Switches. INTERNATIONAL CONFERENCE ON HARMONICS AND QUALITY OF POWER October 14-16 1998, Athens
- [14] L. Palav and A.M. GOLE 'On Using the Solid State Breaker in Distribution Systems'
- [15] Naresh K. Kummari, Asheesh K. Singh "Comparative Evaluation of DSTATCOM Control Algorithms for Load Compensation".
- [16] Dusan Graovac, Vladimir Katic, Alfred Rufer "Power Quality Compensation Using Universal Power Quality Conditioning System".
- [17] Soo-Young Jung, Tae-Hyun Kim, "Analysis and Control of DSTATCOM for a Line Voltage Regulation".
- [18] N. G. Hingorani and L. Gyugyi, Understanding FACTS: Concepts and Technology of Flexible AC Transmission Systems. New York: IEEE Press, 2000, p. 432.
- [19] Chris Fitzer, Mike Barnes and Peter Green "Voltage Sag Detection Technique for a Dynamic Voltage Restorer" IEEE TRANSACTIONS ON INDUSTRY APPLICATIONS, VOL. 40, NO. 1, JANUARY/FEBRUARY 2004
- [20] Vinod Khadkikar "Enhancing Electric Power Quality Using UPQC: A Comprehensive Overview".
- [21] B. S. Mohammed, K. S. Rama Rao, R. Ibrahim, N. Perumal "Performance Evaluation of R-UPQC and L-UPQC Based on a Novel Voltage Detection Algorithm".
- [22] Vinod Khadkikar "UPQC-S: A Novel Concept of Simultaneous Voltage Sag/Swell and Load Reactive Power Compensations Utilizing Series Inverter of UPQC".
- [23] Dr. B. Geethalakshmi and C. Sharmiladevy, "AN IMPROVEMENT IN THE PERFORMANCE OF UNIFIED POWER QUALITY CONDITIONER USING DC-LINK VOLTAGE CONTROL"
- [24] Iman Ziari, Ahad Kazemi, Alireza Jalilian "Using Active Power Filter Based on New Control Strategy to Compensate Power Quality"

- [25] Vadirajacharya.Ki, Pramod Agarwal and H.O. Gupta “CONTROL OF CURRENT- SOURCE ACTIVE POWER FILTER USING UNIT VECTOR TEMPLATE IN THREE PHASE FOUR WIRE UNBALANCED SYSTEM”.
- [26] S. Y. MOSAZADEH, S. H. FATHI and M. HAJIZADEH “Adaptive Hysteresis Band Controlled Grid connected PV System With Active Filter Function”.
- [27] H. Fujita and H. Akagi, “The unified power quality conditioner: The integration of series- and shunt-active filters,” *IEEE Trans. Power Electron.*, vol. 13, no. 2, pp. 315–322, Mar. 1998.
- [28] V. Khadkikar , A. Chandra, A.O. Barry and T. D. Nguyen “Conceptual Study of Unified Power Quality Conditioner”.
- [29] Srinivas Bhaskar Karanki, Mahesh K. Mishra, B. Kalyan Kumar “Comparison of Various Voltage Source Inverter based UPQC Topologies”.
- [30] Yash Pal, A. Swarup and B. Singh “A Comparative Analysis of Three-Phase Four-Wire UPQC Topologies”.
- [31] A.Jaya Laxmi, G.Tulasi Ram Das, K.Uma Rao , K.Sreekanthi and K. Rayudu “Different control strategies for Unified Power Quality Conditioner at load side”.
- [32] M. H. Rashid, *Power Electronics Handbook: Devices, Circuits, and Applications*. New York: Elsevier, 2007
- [33] A. Ghosh and G. Ledwich, *Power Quality Enhancement Using Custom Power Devices*. Boston, MA: Kluwer, 2002.
- [34] H. Akagi, “New trends in active filters for power conditioning,” *IEEE Trans. Ind. Applicat.*, vol. 32, no. 6, pp. 1312–1322, 1996
- [35] M. Rastogi, R. Naik, and N. Mohan, “A comparative evaluation of harmonic reduction techniques in three phase utility interface of power electronic loads,” in *IEEE - IAS Annual Meeting, Toronto, Canada*, Oct. 1993, pp. 971-978.
- [36] B. Singh, K. Al-Haddad, A. Chandra, "A Review of Active Power Filters for Power Quality Improvement", *IEEE Trans on Industrial Electronics*, Vol.45, No.5, Oct1999, pp. 960-071.
- [37] El-Habrouk M., Darwish M.K., Mehta P., "Active power filters: a review" *Electric Power Applications*, IEE Proceedings, Volume: 147, Issue: 5, Sept. 2000, Pages: 403 - 413.
- [38] Ghosh A, Jindal A.K. and Joshi A., "A unified power quality conditioner for voltage regulation of critical load bus", *Power Engineering Society General Meeting*, 2004. IEEE 6-10 June 2004, pp. 471 - 476.

- [39] B. Han, B. Bae, H. Kim, and S. Baek, "Combined operation of unified power-quality conditioner with distributed generation," *IEEE Trans. Power Del.*, vol. 21, no. 1, pp. 330–338, Jan. 2006.
- [40] J.Praveen, B.P. Muni, S. Venkateshwarlu and H.V. Makthal, " Review of dynamic voltage restorer for power quality Improvement," *Proc.IEEE on IECON2004*, Nov.2004, vol.1, pp.749-754.
- [41] M. Aredes, K. Heumann, and E. H. Walandble, "An universal active power line conditioner," *IEEE Trans. Power Del.*, vol. 13, no. 2, pp. 545–551, Apr. 1998.