

# **Design and Analysis of Fractal Antennas for Multiband Applications**

A Dissertation submitted towards the partial fulfilment of  
the requirement for the award of degree of

**Master of Technology in  
Microwave and Optical Communication Engineering**

Submitted by  
**Anand Agrawal**  
**2K14/MOC/03**

Under the supervision of  
**Prof P.R. Chadha**  
**HOD (ECE)**



**Department of Applied Physics and Department of  
Electronics & Communication Engineering**

**Delhi Technological University  
(Formerly Delhi College of Engineering)  
JUNE 2016**



# DELHI TECHNOLOGICAL UNIVERSITY

Established by Govt. of Delhi vide Act 6 of 2009

*(Formerly Delhi College of Engineering)*

SHAHBAD DAULATPUR, BAWANA ROAD, DELHI-110042

## CERTIFICATE

This is to certify that the work which is being presented in the dissertation entitled "**Design and Analysis of Fractal Antennas for Multiband Applications**" is the authentic work of **Anand Agrawal** under my guidance and supervision in the partial fulfilment of requirement towards the degree of Master of Technology in Microwave and Optical Communication Engineering jointly run by Department of Applied Physics and Department of Electronics and Communication in Delhi Technological University during the 2014-16.

As per the candidate declaration this work has not been submitted elsewhere for the award of any other degree.

(Prof. P.R. Chadha)  
HOD(ECE)

## **DECLARATION**

I hereby declare that all the information in this document has been obtained and presented in accordance with academic rules and ethical conduct. This report is my own, unaided work. I have fully cited and referenced all material and results that are not original to this work. It is being submitted for the degree of Master of Technology in Microwave and Optical Communication Engineering at Delhi Technological University. It has not been submitted for any degree or examination in any other university.

**Anand Agrawal  
M. Tech, MOCE  
2K14/MOC/03**

## ACKNOWLEDGEMENT

The thesis work is a result of hard work and contribution of many well-wishers, whose support and guidance has resulted in timely completion of project. I would like to express my deepest gratitude to my supervisor **Prof P.R. Chadha** HOD, Electronics and communication Engineering Department who accepted my request to be my guide and for his invaluable support, quality guidance, priceless knowledge and constant motivation throughout the period of the project that has helped in timely completion and submission of this thesis.

I am deeply grateful to **Prof. S.C. Sharma**, H.O.D (Dept of A.P., **Dr. Priyanka Jain**, **Dr. N.S. Raghava** for their support and for providing us with all the facilities to carry out quality project work.

I also wish to express my heart full thanks to the classmates as well as staff at Department of Applied Physics and Department of Electronics and Communication of Delhi Technological University for their goodwill and support that helped me a lot, in successful completion of this project.

Finally, I want to thank my parents, for inculcating good ethos, as a result of which I am able to do my post-graduation from such an esteemed institution. I would thank my friends for believing in my abilities and for always showering their invaluable support and constant encouragement.

**Anand Agrawal**  
**M.Tech. MOCE**  
**2K14/MOCE/03**

# Contents

<b>Abstract</b> .....	
<b>List of figures</b> .....	
<b>List of Tables</b> .....	
CHAPTER 1 .....	1
<b>THESIS OVERVIEW</b> .....	1
<b>1.1 Introduction</b> .....	2
<b>1.2 Thesis motivation</b> .....	3
<b>1.3 Literature review on multiband fractal antenna</b> .....	4
<b>1.4 Thesis Outline</b> .....	4
CHAPTER 2 .....	6
<b>MICROSTRIP ANTENNA</b> .....	6
<b>MICROSTRIP ANTENNAS</b> .....	7
<b>2.1 Microstrip Antenna</b> .....	7
<b>2.2 Feeding Techniques</b> .....	10
<b>2.3 Advantages and Disadvantages of patch antenna</b> .....	15
<b>2.3.1 Advantages</b> .....	15
<b>2.3.2 Disadvantages</b> .....	15
CHAPTER 3 .....	16
<b>FRACTAL ANTENNA</b> .....	16
<b>3.1 Introduction to Fractal</b> .....	17
<b>3.2 Characteristics of Fractals</b> .....	18
<b>3.3. Features of Fractal antennas</b> .....	18
<b>3.4. Generation of Fractal</b> .....	18
<b>3.5. Construction of Fractal</b> .....	20
<b>3.6. Classification of Fractal antenna</b> .....	20
<b>3.6.1. Sierpinski Carpet</b> .....	21
<b>3.6.2. Sierpinski gasket Fractal antenna</b> .....	22
<b>3.6.3. Koch curve</b> .....	23
<b>3.6.4. Koch Snowflake</b> .....	24

3.6.5 Triadic Cantor Set .....	24
3.6.6 Minkowski fractal antenna .....	25
3.6.7 Hilbert curves.....	25
3.7 Advantages and disadvantages of Fractal antennas .....	26
3.7.1. Advantages.....	26
3.7.2. Disadvantages.....	26
CHAPTER 4 .....	27
<b>DESIGN OF MULTIBAND ANTENNAS USING SIERPINSKI GASKET GEOMETRY</b> .....	27
Introduction to Sierpinski Gasket Geometry .....	28
4.1. Sierpinski Gasket Diamond Antenna.....	28
4.1.1. Design Geometry and Simulation results.....	28
4.1.2. Parametric study .....	34
4.1.3. Radiation patterns.....	34
4.1.4. VSWR.....	35
4.1.5. Gain vs Frequency plot.....	36
4.1.6. Surface current distribution .....	37
4.1.7. Summary.....	38
4.2. Sierpinski Carpet Fractal Antenna .....	39
4.2.1. Design Geometry and Simulation Results.....	39
4.2.2. Return loss .....	41
4.2.3. Radiation Patterns .....	42
4.2.4. Gain vs Frequency plot.....	44
4.2.5. Surface current distribution .....	44
4.2.6. Summary.....	45
CHAPTER 5 .....	46
<b>CONCLUSION AND FUTURE WORK</b> .....	46
5.1. Conclusion.....	47
5.2. Future work.....	47
References .....	48

## **ABSTRACT**

In this report three antenna designs using fractal geometry have been proposed. Fractal is a concept which is being employed in patch antenna to have better characteristics than conventional microstrip antenna. In the first design, a Sierpinski fractal antenna is proposed for multiband wireless applications. It consists of three-stage Sierpinski fractal geometry as the radiating element. The proposed antenna has compact dimension of  $74.5 \times 89 \times 1.45 \text{ mm}^3$ . The multiband characteristic for a return loss less than 10dB is achieved. The model is applied to predict the behavior of fractal antenna when the height of the antenna is changed. The proposed antenna is considered a good candidate for Multiband Wireless applications.

In the second proposal, a Sierpinski Carpet fractal antenna is proposed for multiband wireless applications. It consists of two-stage Sierpinski Carpet fractal geometry as the radiating element. The proposed antenna has compact dimension of  $59.04 \times 47.15 \times 1.6 \text{ mm}^3$ . The multiband characteristic for a return loss less than 10dB is achieved. The major advantage of Sierpinski Carpet antenna is, it exhibits high self-similarity and symmetry.

CST Microwave Studio Suite is used to simulate these antennas. All the proposed antennas are fabricated on FR4 substrate of relative permittivity of 4.4 and height 1.6mm has been used.

# List of Figures

<b>Figure 2. 1</b> Microstrip antenna (a) top view, (b) Electrical field lines,(c) Equivalent length .....	8
<b>Figure 2. 2</b> Different shapes of microstrip patch antennas.....	9
<b>Figure 2. 3</b> Microstrip line feed.....	11
<b>Figure 2. 4</b> Equivalent circuit for microstrip feed line .....	11
<b>Figure 2. 5</b> Probe feed.....	12
<b>Figure 2. 6</b> Equivalent circuit for probe feed line .....	12
<b>Figure 2. 7</b> Aperture coupled feed.....	13
<b>Figure 2. 8</b> Equivalent circuit of Aperture-coupled feed .....	13
<b>Figure 2. 9</b> Electromagnetic coupling .....	14
<b>Figure 2. 10</b> Equivalent circuit of proximity-coupled feed.....	14
<b>Figure 3. 1</b> The affine transform .....	19
<b>Figure 3. 2</b> Minkowski Fractal with succeeding stages showing motif and Generator.....	20
<b>Figure 3. 3</b> Minkowski Fractal with succeeding stages showing motif and Generator.....	21
<b>Figure 3. 4</b> Iteration of the Sierpinski carpet composed of square.....	21
<b>Figure 3. 5</b> Recursive iteration levels of Sierpinski Gasket .....	22
<b>Figure 3. 6</b> Recursive iteration levels of Koch curve.....	23
<b>Figure 3. 7</b> Recursive iteration levels of a Koch snowflake.....	24
<b>Figure 3. 8</b> Construction of the Cantor set .....	24
<b>Figure 3. 9</b> Minkowski Fractal.....	25
<b>Figure 3. 10</b> Hilbert curve .....	25
<b>Figure 4. 1</b> Initiator for Sierpinski Gasket Diamond antenna (a) front view, (b) rear view .....	29
<b>Figure 4. 2</b> Simulated return loss curve for Initiator .....	29
<b>Figure 4. 3</b> First iterated Sierpinski Gasket Diamond antenna (a) Front view, (b) Rear view.....	30
<b>Figure 4. 4</b> Simulated return loss curve for First iterated Sierpinski Gasket Diamond antenna .....	30
<b>Figure 4. 5</b> Second iterated Sierpinski Gasket Diamond antenna (a) Front view, (b) Rear view .....	31
<b>Figure 4. 6</b> Simulated return loss curve for Second iterated Sierpinski Gasket Diamond antenna.....	31
<b>Figure 4. 7</b> Proposed Sierpinski Gasket Diamond antenna (a) front view, (b) rear view .....	32
<b>Figure 4. 8</b> Simulated return loss curve of the final fractal geometry.....	32
<b>Figure 4. 9</b> Simulated return loss curve for different heights of ground plane .....	34



<b>Figure 4. 10</b> Simulated radiation patterns of the Sierpinski Gasket diamond at (a) 0.9 GHz, (b) 2.4 GHz, (c) 5.8GHz (d) 12.6 GHz. ....	35
<b>Figure 4. 11</b> VSWR vs Frequency plot of Sierpinski Gasket Diamond antenna .....	36
<b>Figure 4. 12</b> Simulated gain vs Frequency curve of the proposed antenna.....	37
<b>Figure 4. 13</b> Surface current distribution at (a) 0.9 GHz, (b) 2.4 GHz, (c) 5.8 GHz, (d) 12.6 GHz .....	38
<b>Figure 4. 14</b> Recursive iteration levels of the proposed Sierpinski Carpet antenna (a) Initiator, (b) First iteration, (c) Second iteration.....	40
<b>Figure 4. 15</b> Proposed Fractal Geometry .....	41
<b>Figure 4. 16</b> Simulated return loss curve for the proposed geometry .....	42
<b>Figure 4. 17</b> Simulated radiation patterns at (a) 2.4 GHz, (b) 3.62 GHz, (c) 5.24 GHz .....	43
<b>Figure 4. 18</b> Simulated gain vs Frequency curve of the proposed antenna.....	44
<b>Figure 4. 19</b> Surface current distribution at (a) 2.4 GHz, (b) 3.62 GHz, (c) 5.24 GHz.....	45

# List of Tables

<b>Table 1. 1</b> wireless communication spectrum .....	2
<b>Table 3. 1</b> Difference between Fractal geometry and Euclidean geometry.....	17
<b>Table 4. 1</b> Dimensions of the proposed antenna.....	33
<b>Table 4. 2</b> Simulated results of the proposed antenna.....	33
<b>Table 4. 3</b> Proposed Antenna Dimensions .....	41
<b>Table 4. 4</b> Measured results from the return loss curve .....	42

## CHAPTER 1

# THESIS OVERVIEW

## 1.1 Introduction

Over the last decade wireless communication systems kept fascinating the engineers hence receiving a lot of attentions because of their inherent advantages such as convenience, low cost and ease of fabrication. Wireless Local Area Networks (WLAN) are being universally recognized as a compact, flexible, economic and high speed data connectivity solution. This leads to an outgrowth of microstrip patch antennas [1]. Patch antenna consists of a simple geometry and easy to model. Patch antenna offers numerous advantages which we normally do not see in the conventional antennas. As the size of the patch is small it can be manufactured in large quantities. Patch antennas support both linear and non linear polarization. These are mechanically robust and the fabrication cost incurred is very less. These patch antennas usually don't require cavity backing. Table 1.1 demonstrates the operating frequency ranges of some of the most frequently used wireless communication systems

<b>System</b>	<b>Overall Frequency</b>	<b>Bandwidth</b>
<b>Advanced Mobile Phone Service(AMPS)</b>	<u>Tx</u> : 824-849 MHz Rx: 869-894 MHz	70 MHz (8.1 %)
<b>Global System for Mobile Communication(GSM)</b>	<u>Tx</u> : 880–915MHz Rx: 925–960MHz	80MHz (8.7 %)
<b>Personal Communications Service (PCS)</b>	<u>Tx</u> : 1710–1785MHz Rx: 1805–1880MHz	170MHz (9.5 %)
<b>Global System for Mobile Communications (GSM)</b>	<u>Tx</u> : 1850–1910MHz Rx: 1930–1990MHz	140MHz (7.3 %)
<b>Wideband Code Division Multiple Access (WCDMA)</b>	<u>Tx</u> : 1920–1980MHz Rx: 2110–2170MHz	250MHz (12.2 %)
<b>Universal Mobile Telecommunication Systems (UMTS)</b>	<u>Tx</u> : 1920–1980MHz Rx: 2110–2170MHz	250MHz (10.2 %)
<b>Ultra-wideband (UWB) communications and measurement</b>	3100–10,600MHz	7500MHz (109 %)

**Table 1. 1** wireless communication spectrum

For mobile or Wireless LAN applications a single antenna is highly desirable if it can operate at multiple bands. In accumulation, the antenna used for WLAN must be in planar form, compact, light weight and simple to fed, so that it can be embedded in communication devices.

## **1.2 Thesis motivation**

In modern communication systems, multiband behavior with good gain is essential for many applications, such as GSM, GPS, and PCS services function at two different frequency bands. Wi-Fi, WLAN systems require single band operation. Integration of many applications is also required in the wireless world. So it wants same antenna to be handled for all of the integrated applications.

After pioneering research in the wireless communication leads to the evolution of microstrip antenna. Microstrip antenna offers numerous advantages as well as some disadvantages compared to the conventional one. The disadvantage includes lower gain, excitation of surface waves, narrow bandwidth, high quality factor (Q), Ineffective use of available physical area and low power handling due to its smaller size. Researchers proposed several approaches to shrunken the antenna size, enhancement in bandwidth by decreasing the quality factor.

Today's small handheld devices challenge antenna designers for ultra-thin, convenient and high performance devices that have the capability to meet the multi standards. This feature emerged antenna examination in different ways, one of the method is the use of fractal shaped geometry. Fractal is a concept extension to the microstrip antenna. In modern years many geometrical structures have been proposed with different degree of achievement in enhancing antenna characteristics. Fractals will expand the bandwidth and shrunken the parameter dimensions of the antenna [5]. Fractals will increase the total electrical length of the antenna keeping the total area same. Self-similarity, space nature of the fractal antenna is usually required in the development of multiband operation.

## 1.3 Literature review on multiband fractal antenna

The creation of Microstrip patch antennas has been accredited to a number of researchers, but it certainly dates back to the 1960s when the first works was published by Deschamps, Greig and Engleman, and Lewin, among others. Since 1970, severe research came into picture with the first design equations. Since then different authors started research on Microstrip patch antennas like James Hall and David M. Pozar and many more who contributed a lot.

Fractal is a concept extension to the microstrip antenna. The word “fractal” was termed by Benoit Mandelbrot in 1961. Sometimes he is referred to as the predecessor of fractal geometry. He said, “I coined fractal from the Latin adjective”.

In many fractal antennas, the self-affinity and space-filling nature of fractal geometries are often quantitatively linked to its frequency characteristics. Fractals are geometrical structures, which are self-similar, repeating at regular intervals of time. The geometry of fractals is significant because the physical length of the fractal antennas can be enlarged while keeping the total area same. Final fractal geometry can be formed by an iterative mathematical procedure called, *Iterative Function Scheme* (IFS).

## 1.4 Thesis Outline

The outline of this thesis is as follows.

Chapter 2 illustrates the basic theory behind the Microstrip patch antennas. This chapter also deliberate about different patch structures, various feeding techniques employed labeling their characteristics. Finally this chapter ends with the advantages and disadvantages of patch antennas.

Chapter 3 illustrates about fractal antennas. Fractal is a new concept extension to the patch antenna. Chapter presents the characteristics, features, generation of fractals (IFS), construction of fractals and classes of fractals. Finally the chapter ends with the advantages and disadvantages of using fractals in the patch antenna.

Chapter 4 contains two sections. First section contains the design of multiband fractal antenna using Sierpinski Gasket Diamond geometry, and the second section contains the design of fractal antenna using CPW fed Sierpinski Carpet. Both of these antennas are analyzed using CST microwave studio. Patch performance parameters such as return loss, radiation patterns and gain are also presented in this chapter. The effect of iterations on the patch antenna are shown.

Chapter 5 contains conclusion and scope of future work.

## CHAPTER 2

# **MICROSTRIP ANTENNA**



# MICROSTRIP ANTENNAS

Microstrip is also referred as patch antenna. Now a days microstrip antenna find so many applications in many fields and becoming more popular due to several advantages. It has the advantage of being a low profile antenna and easy to manufacture by using modern printed circuit technology that makes it best suitable candidate for the hand-held and mobile equipment.

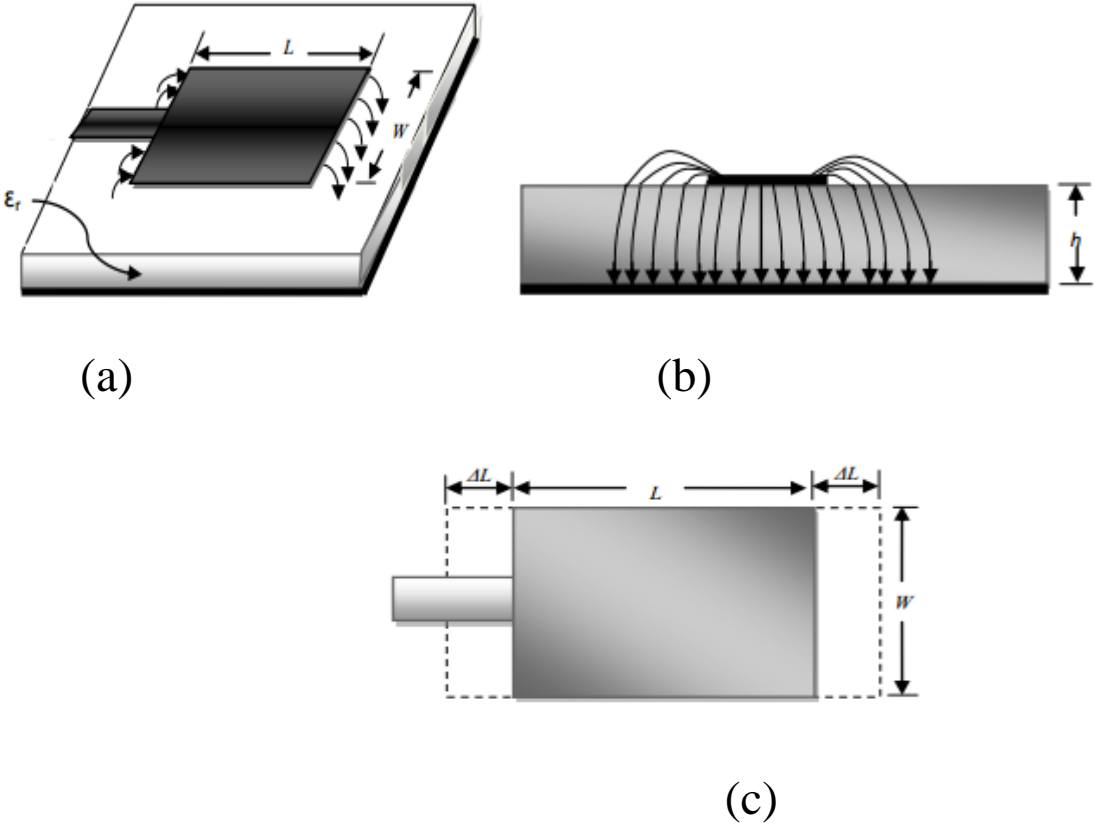
## 2.1 Microstrip Antenna

Microstrip antennas gets the enormous attention of researcher in 1970s. While earlier in 1953 Deschamps [9] observed that the microstrip structure are able to radiate electromagnetic energy into space. After two years in 1955 Gutton and Baissinot got a patent [10] in the field of microstrip radiator. In now a day microstrip antenna is a major topic for the researchers. Microstrip antenna finds their application in the field where a high performance antenna is wants. Some of their applications are in spacecraft, aircraft, vehicles, satellite, and missile, where a low weight, small size, easy to install and a shock resistant antenna [11] is required. The major demerit of patch antenna is that it has a narrow bandwidth. While this demerit can be remove by using a high dielectric material for antenna substrate, but it will results in low efficiency. Increasing the dielectric constant of substrate material also leads to introduce surface waves in the substrate which results in loss of energy. Recently researcher got a number of techniques to increase the bandwidth of microstrip antenna such as using stacked patches, metamaterials, defected ground plane and defected patch structures and use of Electronic band Gap EBG structure. While there are many government and military applications where a narrow bandwidth antenna is required, microstrip antennas are used. Microstrip Patch antennas are the new group of antennas that having a gorgeous features such as low profile, light weight, low cost and simple to form an arrays. These features make them ideal constituents of modern cellular, Digital communication and WLAN applications [9].

Microstrip antennas have two metallic plates one is patch and other one is ground plane. Patch is on one side of dielectric substrate and other side ground plane is placed. The top view and

side view of patch antenna is shown in fig 2.1. Usually we require good conductor for transmission of signals as well as for reception, so in order to satisfy this criteria we are going for copper or gold metal as a radiating element in microstrip antenna.

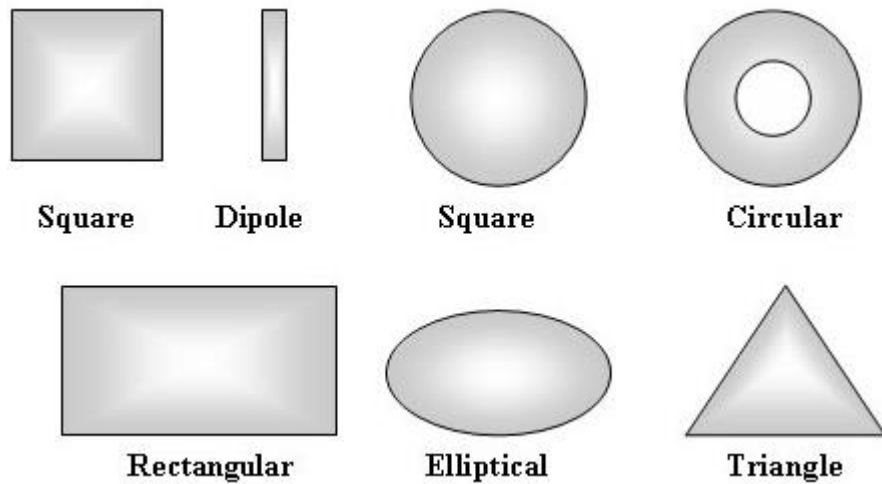
One of the major advantages of microstrip antenna is that it is very suitable with printed circuit technology can be easily fabricate with the feed line and matching network structure on a dielectric sheet. Microstrip or patch antenna can be design with any shape and any size, for example the basic and mostly used shapes are square, trapezoidal, rectangular, circular, elliptical, ring shape, triangular, or any other geometry. Some demonstrative forms of microstrip patch elements are illustrated in fig 2.2. Although in most of the cases we use square, rectangle, strip, and circular as the radiating element because of the advantages that they can easily analysis by the theoretical models and symmetric structure, also very easy to apply various bandwidth improvement techniques on it.



**Figure 2. 1** Microstrip antenna (a) top view, (b) Electrical field lines,(c) Equivalent length

Basically antennas can be radiated in two ways. One is broadside and other is end-fire radiation. In broadside radiation maximum pattern is normal to the axis of the antenna or patch, whereas in end-fire radiation maximum pattern is along the axis of the antenna or patch. Microstrip patch antenna falls under the category of broadside radiator.

The design of microstrip antenna can be done by using numerous substrates. Normally the dielectric constant ( $\epsilon_r$ ) takes any value between 2.2 to 12. Generally low dielectric constant material substrate with high thickness is used in order to achieve a higher bandwidth, improved radiation and good efficiency. But the size of antenna increased. In order to reduce the size of the Microstrip patch antenna higher dielectric constant material can be used. But higher dielectric constant material causes to poor radiation efficiency [12] [13].



**Figure 2. 2** Different shapes of microstrip patch antennas

The quality factor is one of the parameter that effects the antenna performance. The quality factor is a figure-of-merit of the antenna that represents the losses associated with an antenna [14]. The total quality factor  $Q_t$  contributes the losses due to radiation, conduction, dielectric and surface waves can be given as

$$\frac{1}{Q_t} = \frac{1}{Q_c} + \frac{1}{Q_d} + \frac{1}{Q_{sw}} + \frac{1}{Q_{rad}}$$

Where

$Q_t$  = Total quality factor

$Q_c$  = quality factor affected due to conduction losses

$Q_d$  = quality factor affected due to dielectric losses

$Q_{sw}$  = quality factor affected due to surface waves

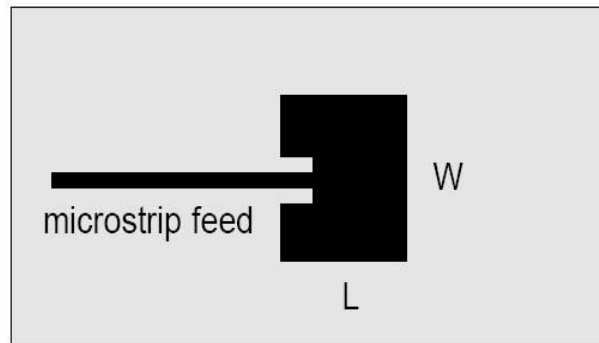
$Q_{rad}$  = quality factor affected due to radiation losses

## 2.2 Feeding Techniques

Different types of feeding methods can be used to feed the microstrip patch antenna. On the basis of how the antenna is fed we can categorize the feeding mechanism in two parts: contacting and non-contacting. In the contacting feedings the feeding line has a direct contact with the radiating patch. While in the case of non-contacting feeding methods the energy is electromagnetically coupled from the microstrip line to the radiating patch [8]. Four mostly used feeding techniques are

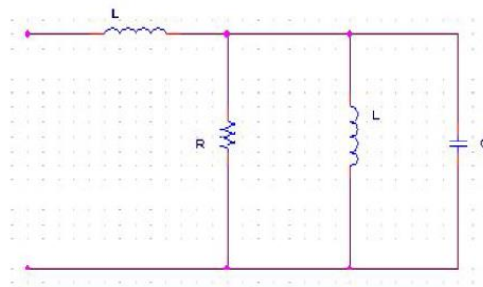
- Microstrip feed line
- Coaxial probe feed
- Aperture coupled feed
- proximity coupled feed

Microstrip feed is also called as inset feed, consists of a conducting strip. Generally the conducting strip width is smaller than the width of the radiating patch. It is simple to model, can be easily fabricated with the patch on the substrate, and easy to get impedance matching by using inset feed. However, this feed mechanism suffers from surface wave and spurious feed radiation. A microstrip patch antenna with a microstrip feed line and its electrical equivalent circuit are shown in figures below.



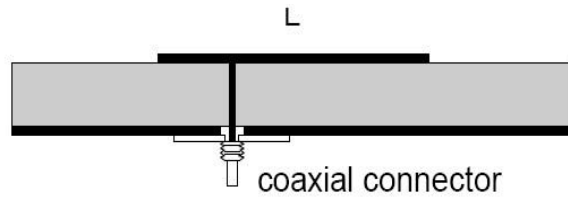
top view

**Figure 2. 3** Microstrip line feed

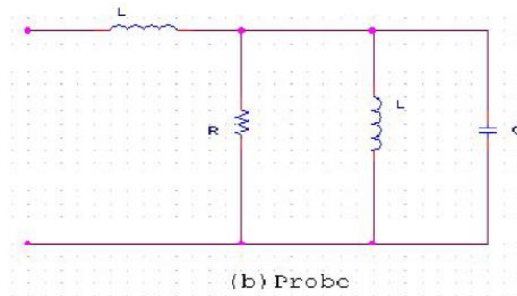


**Figure 2. 4** Equivalent circuit for microstrip feed line

In Coaxial probe feeding the core conductor of coaxial line is directly connected to the radiating patch through a slot from the ground plane and the substrate using the soldering and the outer conductor is made connected to the ground plane. The coaxial probe feed has low spurious feed radiations. It's easy to achieve the proper impedance matching by finding the driving point where the input impedance is equal to that of the feed line and feeding directly on that point. Antenna with probe feed and its equivalent circuit are shown in Fig.



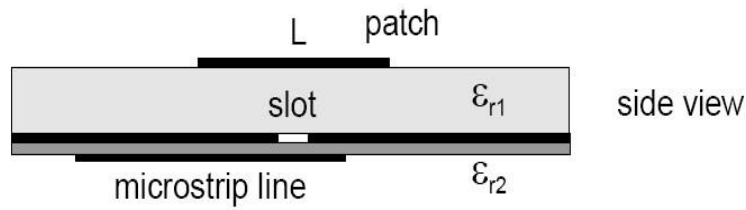
**Figure 2. 5** Probe feed



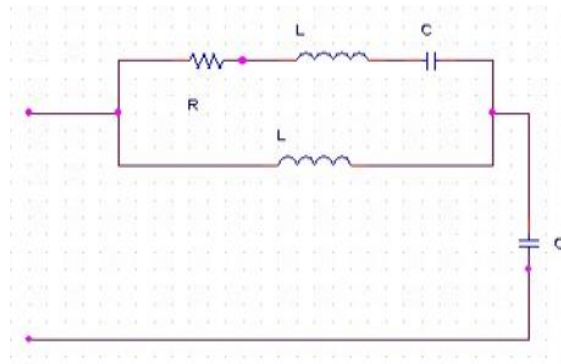
**Figure2.6** Equivalent circuit for probe feed line

In Aperture coupled feeding two types of dielectric substrate are used. These dielectric substrates are separated by the metallic ground plane. The upper one substrate is known as Superstrate. The upper one substrate is responsible for the radiation from the patch that therefore the lower dielectric material with high thickness is preferred for the Superstrate and the lower one used for the energy coupling therefore a high dielectric material with less height is used for lower substrate.

Generally microstrip feed line is used in this feeding which is placed below the lower substrate and the energy from feed line is coupled electromagnetically through an aperture made on the ground plane. Different types of aperture are used in this type of feeding. Rectangular and circular are most common and cross and ring shape slots are used for circular polarization. An antenna with aperture-coupled feed its equivalent circuit is shown in figure. Aperture coupled feeding is simple to model and has low spurious radiation, but difficult to fabricate due to alignment of multiple layers and has narrow bandwidth.

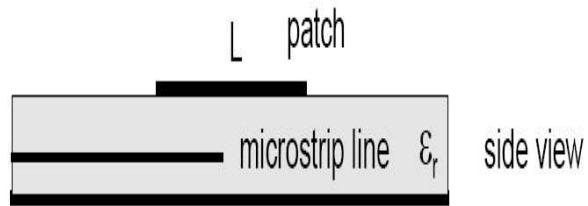


**Figure 2. 7** Aperture coupled feed

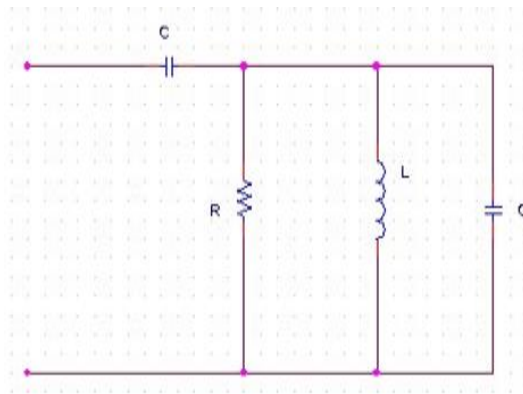


**Figure 2. 8** Equivalent circuit of Aperture-coupled feed

Proximity coupled technique also uses two substrates. The selection of substrate materials are choosing same as in the aperture coupled feed. The feed line separates the two substrate. The Ground plane is placed below the lower substrate. As compared to the other types of feeding proximity coupled feed has the maximum bandwidth. Although, it is also difficult to fabricate and thickness of patch antenna increases because of multiple layers. Antenna with proximity-coupled feed is shown in figure with its electrical equivalent circuit [15].



**Figure 2. 9** Electromagnetic coupling



**Figure 2. 10** Equivalent circuit of proximity-coupled feed



## **2.3 Advantages and Disadvantages of patch antenna**

Patch antennas have numerous advantages as well as some disadvantages. Some of them are listed below.

### **2.3.1 Advantages**

- A range between 100 MHz to 100 GHz is covered by patch antennas.
- No cavity backing is required
- It can be manufactured easily
- The fabrication cost incurred is very less so it can be manufactured in large quantities
- They are very good radiators
- Patch antennas support both linear polarization and circular polarization
- These are mechanically robust

### **2.3.2 Disadvantages**

- Reduced gain and efficiency
- Surface waves are generated leads to unwanted or spurious radiation.
- Narrow BW and associated tolerance problems
- High Q (quality factor)
- Ineffective use of available physical area
- Patch antennas accepts low power due to its low profile

## CHAPTER 3

# **FRACTAL ANTENNA**

### 3.1 Introduction to Fractal

Today's small handheld devices challenge antenna designers for ultra-thin, convenient and high performance devices that have the capability to meet the multi standards [2]. This feature emerged antenna examination in different ways, one of the method is the use of fractal shaped geometry [3] [4]. Fractal is a concept extension to the microstrip antenna. In modern years many geometrical structures have been proposed with different degree of achievement in enhancing antenna characteristics.

Fractals can be found from natural surroundings or produced using a mathematical formulae. Fractal was first invented by Benoit Mandelbrot [16], and he is known as the predecessor of fractal geometry. He stated, "I devised fractal from the Latin adjective". As compared with the Euclidean geometry antenna fractal are known for their ability to fill the space available more effectively. The basic difference between traditional Euclidean geometry and fractals are discussed in Table 3.1.

Fractal geometry	Euclidean geometry
These are defined by fractal geometry	These are defined by formula
They have structure on many scales	They have structure on one or few scales
Dilation geometry	No self –similarity
Fractal dimension is possible	Integer dimension is possible

**Table 3. 1** Difference between Fractal geometry and Euclidean geometry

## 3.2 Characteristics of Fractals

Fractals are geometrical structures, which are self-similar, repeating at regular intervals of time. One of the most distinctive characteristics of fractal is self-similarity [5]-[7]. Five important characteristics of fractals are given by

- They have details on arbitrary scales
- Fractals contains complex geometries.
- Fractal shapes possess self-similarity
- Fractals are defined by iterative rule
- Fractals have fractal dimension

## 3.3. Features of Fractal antennas

- Self-similarity feature is useful in designing multiband antenna
- Small dimension is essentially useful in the design of electric small antennas
- Increasing the number of iterations enhances the electrical length of an antenna
- Space filling ability is necessary to miniaturize the antenna size

Other important factors of fractal are

- Fractals don't have any characteristics shape.
- Fractals have infinite range of scales within their structure.
- They are highly convoluted and having irregular structures.

## 3.4. Generation of Fractal

Iterated function system fractals are generated by a simple plane transformations. Affine transformation is used to describe about IFS [17]. Affine transformations are composed of

- Scaling parameters
- Rotational parameters
- Reflection parameters
- Translational parameters

The expression for affine transformation is given by

$$\begin{pmatrix} x_{n+1} \\ y_{n+1} \end{pmatrix} = \begin{pmatrix} a & b \\ c & d \end{pmatrix} \begin{pmatrix} x_n \\ y_n \end{pmatrix} + \begin{pmatrix} e \\ f \end{pmatrix} \quad (3.1)$$

Scaling parameters a, b, c and d are always real integers [18]. Parameters a, b, c and d are governs scaling and shearing. Whereas e and f are responsible for linear translation. Therefore, the linear affine transformation, W is defined by this constraints as given below.

$$\begin{pmatrix} a & b \\ c & d \end{pmatrix} \begin{pmatrix} e \\ f \end{pmatrix}$$

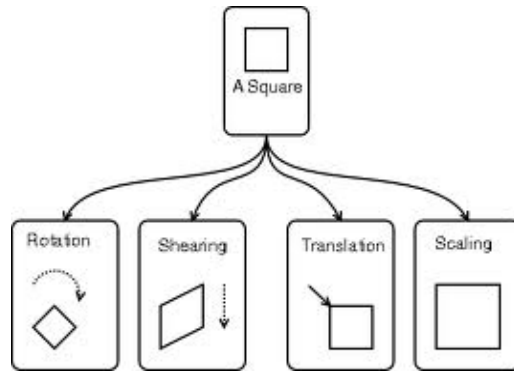
Let us consider  $F_0$  is our initial geometry. Apply linear affine transformations to the initial geometry using generator to get the first iterated structure. There are infinite number of iterations possible, but practically only few iterations are possible due to numerical limitations.

$$F_1 = W(F_0); F_2 = W(F_1); \dots \dots \dots F_\infty = W(F_{\infty-1}).$$

Or it can also be represented by

$$F_{m+1} = \bigcup_{n=1}^N W(F_m) \quad (3.2)$$

Where  $W$  is known as the Hutchinson operator. The affine transformation is presented in figure 3.1



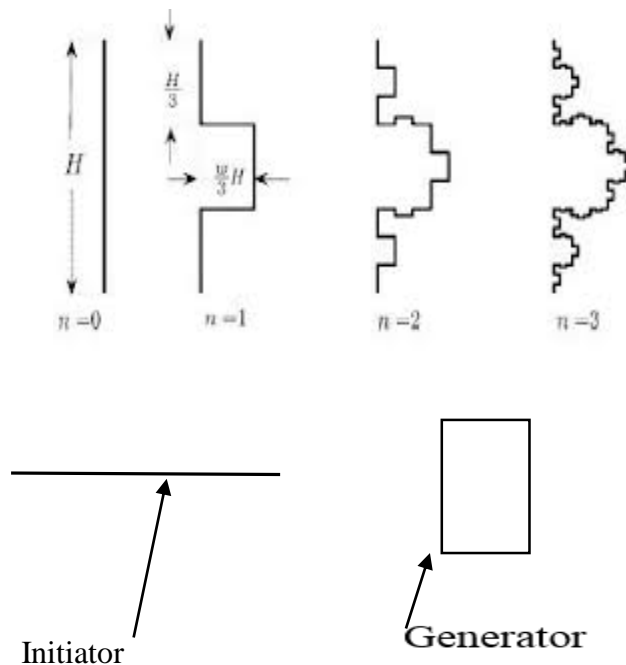
**Figure 3. 1** The affine transform

### 3.5. Construction of Fractal

Fractal geometry has two constituents

- 1) Initiator or motif (0<sup>th</sup> stage): The initial geometry of the fractal antenna
- 2) Generator or attractor: It is a collection of scales copies of the motif

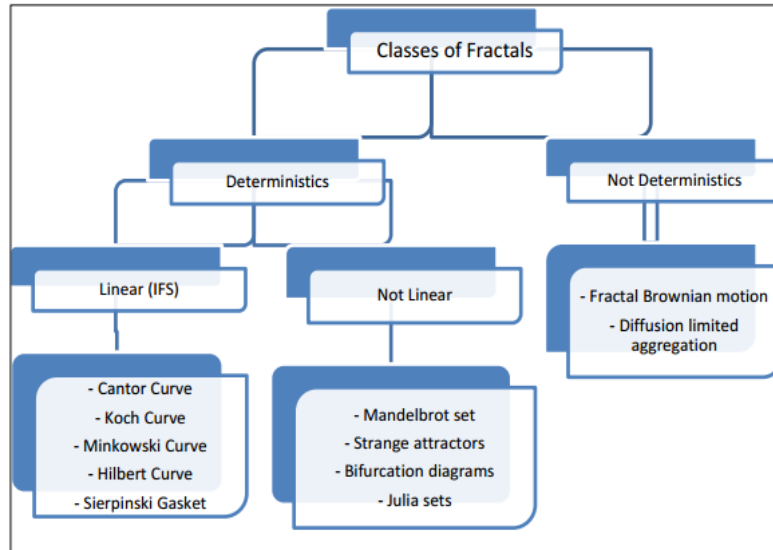
The figure 3.2.denotes one type of fractal which is called as Minkowski, here rectangle is used as a generator. The motif is shown in the leftmost end and the iterative procedure for the motif gives the generator which is nothing but scaled copy of motif.



**Figure 3. 2** Minkowski Fractal with succeeding stages showing motif and Generator

### 3.6. Classification of Fractal antenna

There are different types of fractals described in a flow chart form in Fig. 3.3. Fractals broadly classified into two types one is *Deterministic* and the other is *Non- Deterministic*. In this chapter we want to discuss about Deterministic fractals which are again categorized as *linear* and *Non-Linear* geometry.

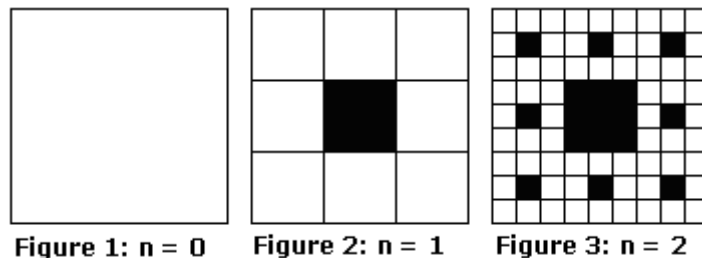


**Figure 3. 3** Minkowski Fractal with succeeding stages showing motif and Generator

Linear geometry is obtained by using *Iterative Function System (IFS)* which is major topic of our discussion in this chapter.

### 3.6.1. Sierpinski Carpet

Sierpinski carpet was invented by Sierpinski in 1916. Sierpinski carpet Fractal antenna uses square as a generator instead of triangle. Square is taken as a generator for Sierpinski Carpet. Then apply series of affine transformation using square to get the generator, repeat this procedure until the final geometry is obtained. The number of squares obtained after first iteration is 9, and the scaling factor is 3.



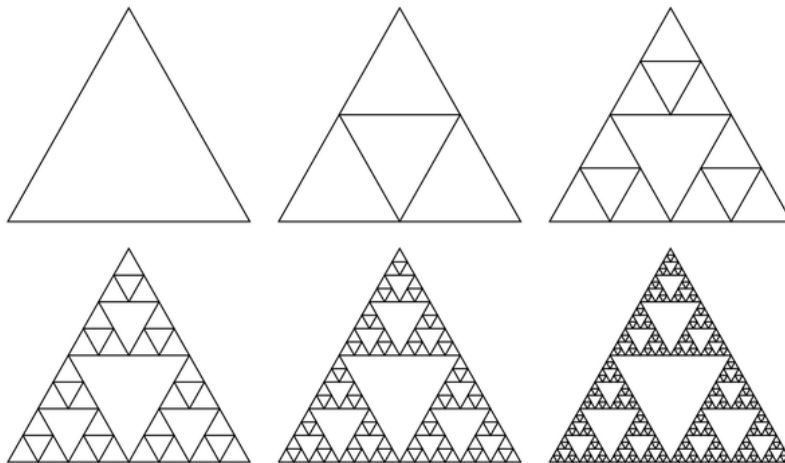
**Figure 3. 4** Iteration of the Sierpinski carpet composed of square

Then the Fractal dimension is given by

$$D = \frac{\log 8}{\log 3} = 1.8928$$

### 3.6.2. Sierpinski gasket Fractal antenna

Sierpinski gasket is the basic fractal geometry to get multiband behaviour in antenna applications. This was invented by Polish mathematician Sierpinski in 1916 [17]. Inverted triangle is taken as a generator for Sierpinski Gasket [5]. Then apply series of affine transformation using triangle to get the generator, repeat this procedure until the final geometry is obtained [19].



**Figure 3. 5** Recursive iteration levels of Sierpinski Gasket

Scaling factor used for Sierpinski gasket is 2, the number of copies obtained after first iteration is 3, then the fractal dimension is given by.

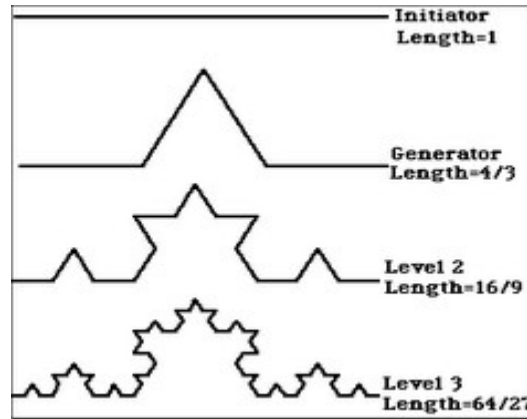
$$D = \frac{\log 3}{\log 2} = 1.585$$

The numerator term represents the number of pieces obtained after first iteration, and the denominator term represents the scaling factor.



### 3.6.3. Koch curve

Koch curve has an endless electrical length and it was invented by Triadic von Koch [20]. Each segment of length  $L$  is divided into three equal parts of length  $L/3$ , the middle portion of the segment is replaced by a generator. Fig.3.6 represents the triadic von Koch curve.



**Figure 3. 6** Recursive iteration levels of Koch curve

At 0<sup>th</sup> iteration, the segment of length  $L$  is used as a motif for Koch curve. After first iteration motif is replaced by three segments of lengths  $L/3$ .

After 1<sup>st</sup> iteration, koch length is given by

$$L = 4/3$$

In the second iteration, the scaling factor used for koch is 9. After 2<sup>nd</sup> iteration total length is given by

$$L = 16/9 \text{ or } L = (4/3)^2$$

After 3<sup>rd</sup> iteration, the total length is increased by maintaining the same physical space and that is given by

$$L = 64/27 \text{ or } L = (4/3)^3$$

This procedure is continued till the final geometry is obtained [20]. The mathematical expression used for calculating the length of the koch is given by

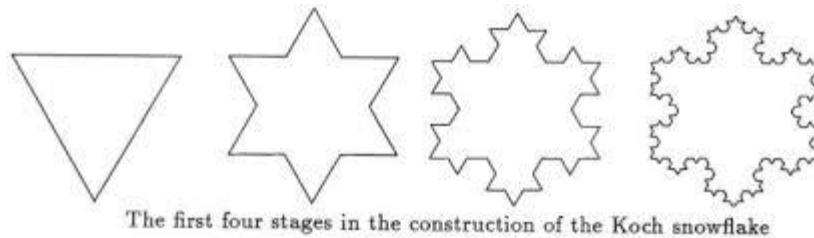
$$L = (4/3)^n$$

Where L represents the length of the koch and n represents the iteration number.  
 Fractal dimension used for koch is given by

$$D = \frac{\log 4}{\log 3} = 1.261$$

### 3.6.4. Koch Snowflake

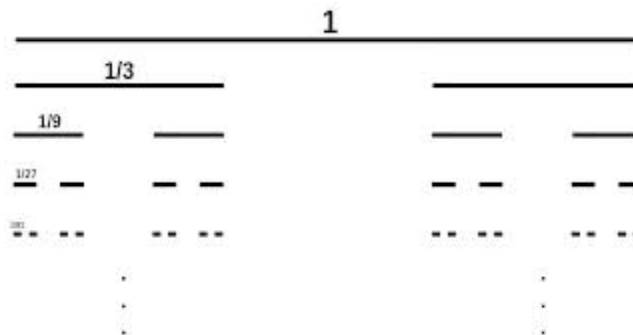
A Koch snowflake is produced by preliminary with an equilateral triangle as a generator and then altering each line segment recursively. Koch snowflake is also known as Koch island. Fractal dimension used for koch snowflake is in between  $1 < D < 2$ .



**Figure 3. 7** Recursive iteration levels of a Koch snowflake.

### 3.6.5 Triadic Cantor Set

Cantor set is a set of points lying on a single line segment. Cantor set was invented by Henry John Stephen Smith [21]. This is another best example in order to get clear idea about Fractal. In triadic cantor set each segment of length L is replaced by three equal segments of lengths L/3, in that the middle portion segment is removed from the motif [22].



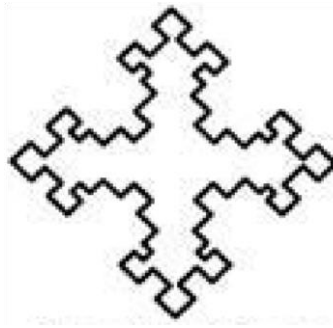
**Figure 3. 8** Construction of the Cantor set

Fractal dimension used for cantor set is given by

$$D = \frac{\log 2}{\log 3}$$

### 3.6.6 Minkowski fractal antenna

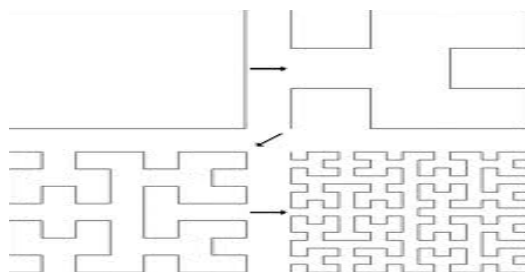
These can be used widely to miniaturize the size of antenna by enhancing the efficiency with which fills up employed volume with electrical length. It is analyzed where the perimeter is one wavelength. Numerous iterations are compared with a square loop antenna to demonstrate the advantages of using fractal antenna [22], it is shown in Fig.3.9. It is exciting to note that Minkowski fractal antennas are not only broadband, but they also establish multiband effects. Minkowski island fractals useful to attain miniaturization in antenna systems while keeping an identical electromagnetic performance to the square loop antenna [23].



**Figure 3. 9** Minkowski Fractal

### 3.6.7. Hilbert curves

Hilbert curve is one of the fractal curves which uses available physical space very effectively . Because of this property it has become an attractive candidate for use in the design of fractal antennas .



**Figure 3. 10** Hilbert curve

## **3.7 Advantages and disadvantages of Fractal antennas**

There are numerous advantages as well as some disadvantages with Fractal antennas. They are deliberated in detail in the subsections below.

### **3.7.1. Advantages**

The benefits of using Fractals in microstrip antenna are demonstrated in here. Some of them are

- It uses available physical area very effectively.
- At higher frequencies the finite element antenna is naturally broadband.
- Enhanced reliability
- The construction cost is reduced.
- Polarization and phasing of FEA also are possible.
- Fractals don't need any matching constituents to achieve broadband or multiband performance.

### **3.7.2. Disadvantages**

With a number of benefits of using fractals in microstrip antenna, there are some disadvantages associated with it too. They are as follows:

- They have Low Gain
- The geometry of Fractal design is complex
- We have to take care of numerical Limitation
- Practically few iterations are possible

## CHAPTER 4

# **DESIGN OF MULTIBAND ANTENNAS USING SIERPINSKI GASKET GEOMETRY**

## Introduction to Sierpinski Gasket Geometry

This chapter analyses the multiband behavior of planar monopole antennas [5] using Sierpinski Gasket. Through the use of the fractal geometry these designs are able to meet the multiband behavior. The first section demonstrates about the Sierpinski Gasket Diamond antenna and the other section illustrates about Sierpinski Carpet. In the first section, the antenna performance is evaluated by creating iterated fractal diamonds to the planar microstrip antenna.

In the second section the microstrip patch antenna analyzed using iterated Sierpinski Carpet geometry. FR4 substrate used as a dielectric for both of these designs with the relative dielectric constant value of 4.4. The thickness of substrate is taken as 1.6mm for these designs. Both of these designs are best matched with 50 ohm input impedance. Antennas are simulated using CST microwave studio 2012, simulated results shows that the antenna has a decent performance with 10dB return loss. Gain, radiation patterns are also presented in this chapter

### 4.1. Sierpinski Gasket Diamond Antenna

A Sierpinski fractal antenna is proposed for multiband wireless applications. It consists of three-stage Sierpinski fractal geometry as the radiating element. The proposed antenna has compact dimension of  $74.5 \times 89 \times 1.45 \text{ mm}^3$ . The multiband characteristic for a return loss less than 10dB is achieved. The prototype is useful to predict the performance of Sierpinski Gasket diamond fractal antenna when the height of antenna is changed. The proposed design is considered a good candidate for Multiband Wireless applications.

#### 4.1.1. Design Geometry and Simulation results

Sierpinski gasket is the basic fractal geometry to get multiband behaviour in antenna applications. This was invented by Polish mathematician Sierpinski in 1916. Classical Sierpinski triangle is having the scale factors are given by

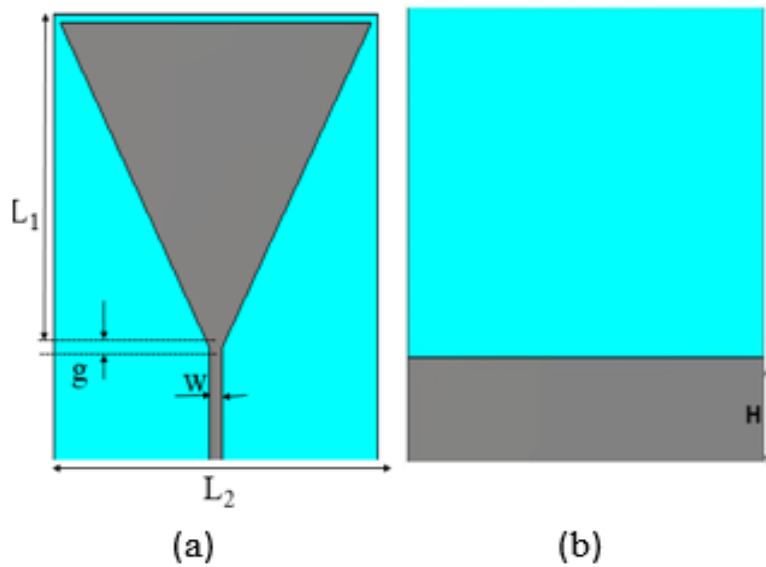
$$\delta = h_n / h_{n+1}$$

Where h represents the height of the diamond and n represents the iteration number. The proposed antenna having different scale factors ( $\delta_1 = h_1/h_2$  and  $\delta_2 = h_2/h_3$ ). It is printed on a 1.6 mm thick

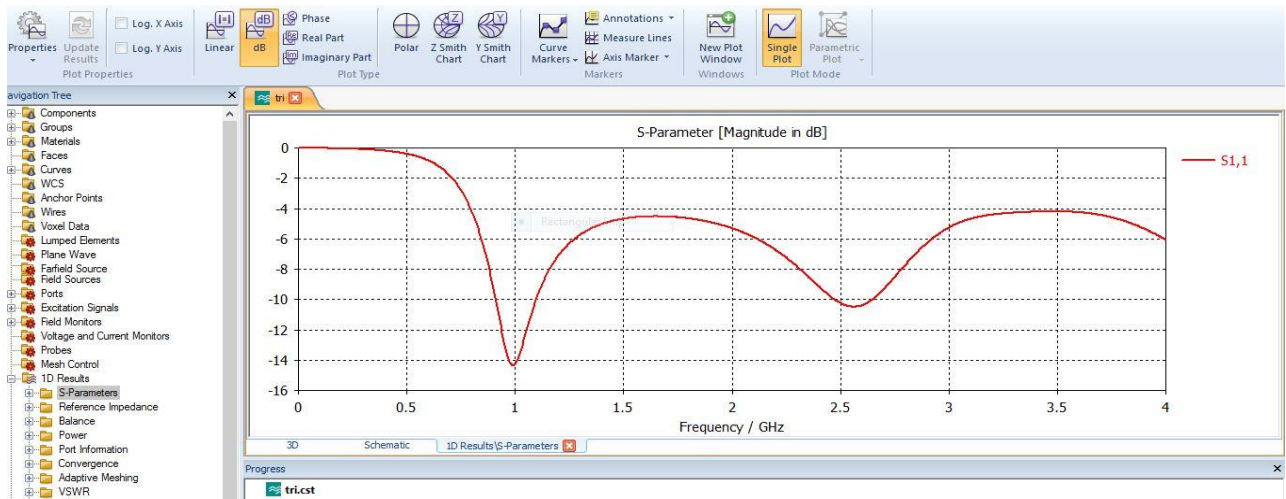
substrate, relative dielectric constant value ( $\epsilon_r$ ) of 4.4, with the size  $74.5 \times 89 \text{ mm}^2$ . These antennas are simulated using CST microwave studio.

### Initiator or motif

The initiator for Sierpinski Gasket Diamond antenna is an inverted triangle fed by a microstrip feed line. The initiator gives good impedance matching at 0.9 GHz responsible for GSM.



**Figure 4.1** Initiator for Sierpinski Gasket Diamond antenna (a) front view, (b) rear view



**Figure 4.2** Simulated return loss curve for Initiator

## First iteration

The diamond of diameter  $d_1$  is used as a generator or attractor for this design. First iterated Sierpinski Gasket is shown in figure 4.3. Initiator gives first resonant frequency at 0.9 GHz responsible for GSM. With the inclusion of first iteration in motif, it gives one more resonant frequency at 2.4 GHz responsible for Bluetooth.

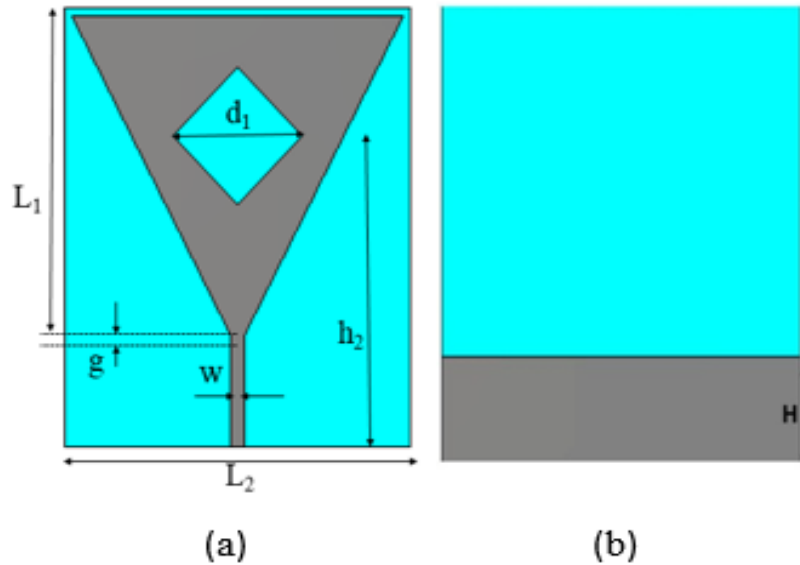


Figure 4. 3 First iterated Sierpinski Gasket Diamond antenna (a) Front view, (b) Rear view

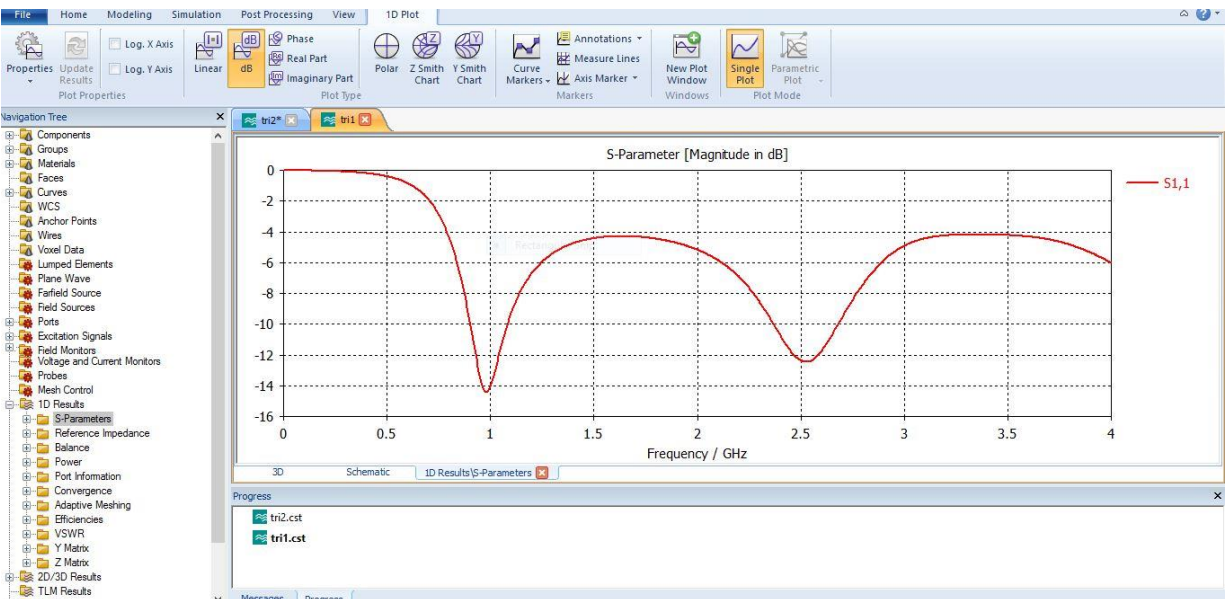


Figure 4. 4 Simulated return loss curve for First iterated Sierpinski Gasket Diamond antenna



## Second iteration

The diamonds of diameters  $d_1$  and  $d_2$  is used to get the two resonant frequencies. Second iterated Sierpinski Gasket is shown in figure 4.5. Addition of iteration gives one more resonant frequency at 5.8 GHz responsible for WLAN.

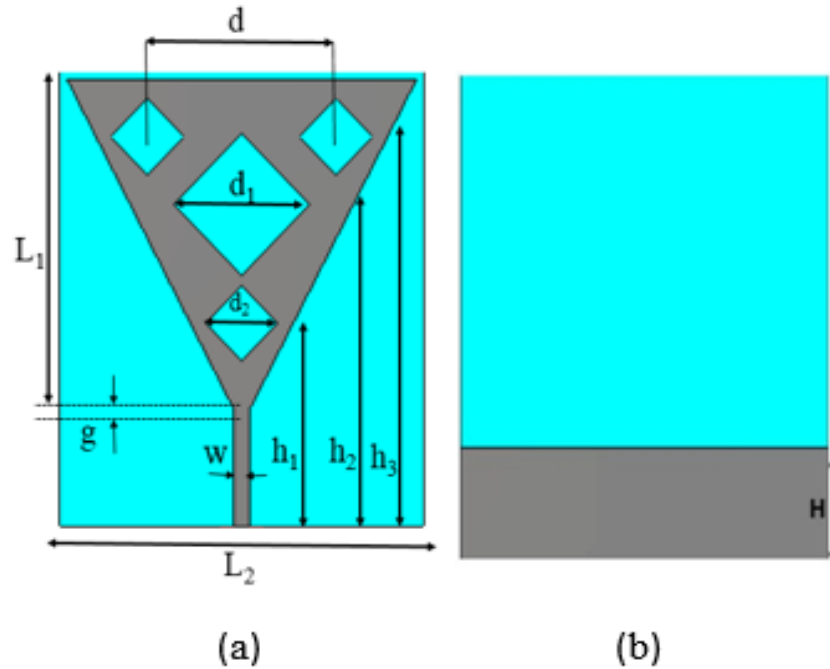


Figure 4. 5 Second iterated Sierpinski Gasket Diamond antenna (a) Front view, (b) Rear view

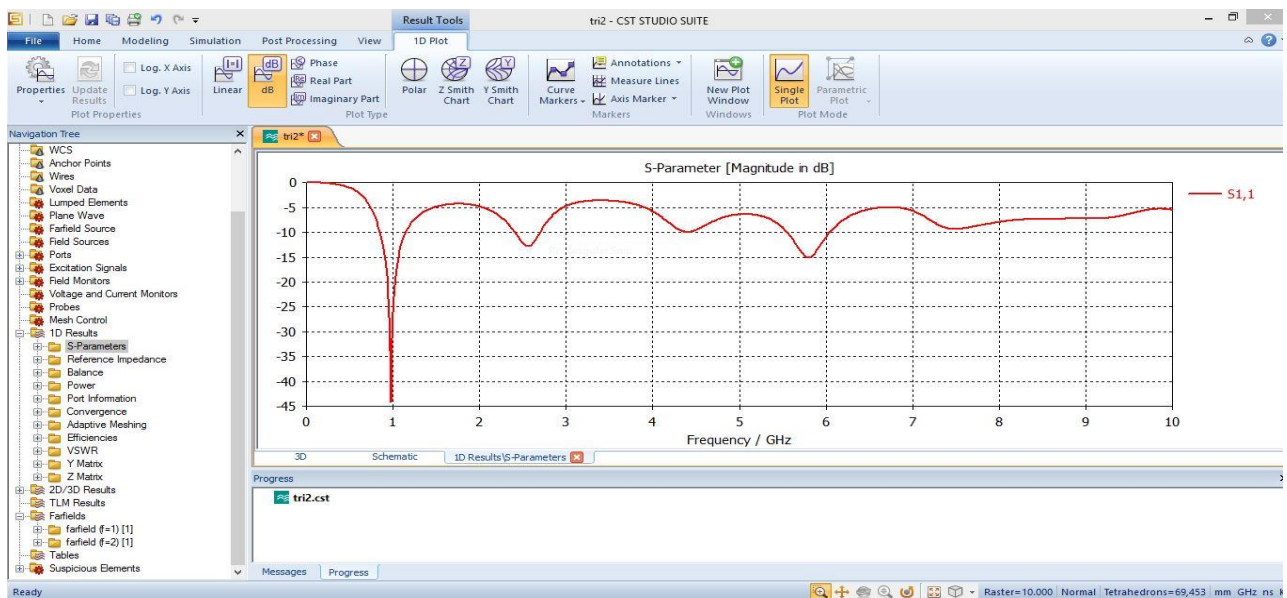


Figure 4. 6 Simulated return loss curve for Second iterated Sierpinski Gasket Diamond antenna

### Third iteration

A fourth pass band can be added using the small diamond slots of diagonal length of 6 mm. Inclusion of iteration gives one more resonant frequency.

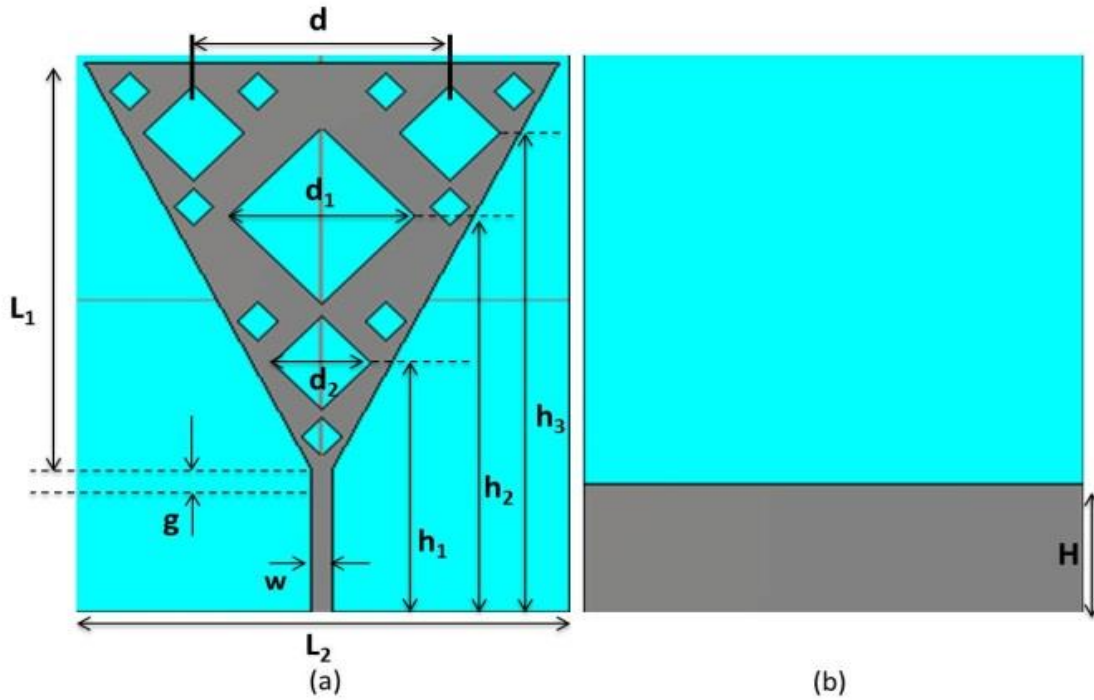


Figure 4. 7 Proposed Sierpinski Gasket Diamond antenna (a) front view, (b) rear view

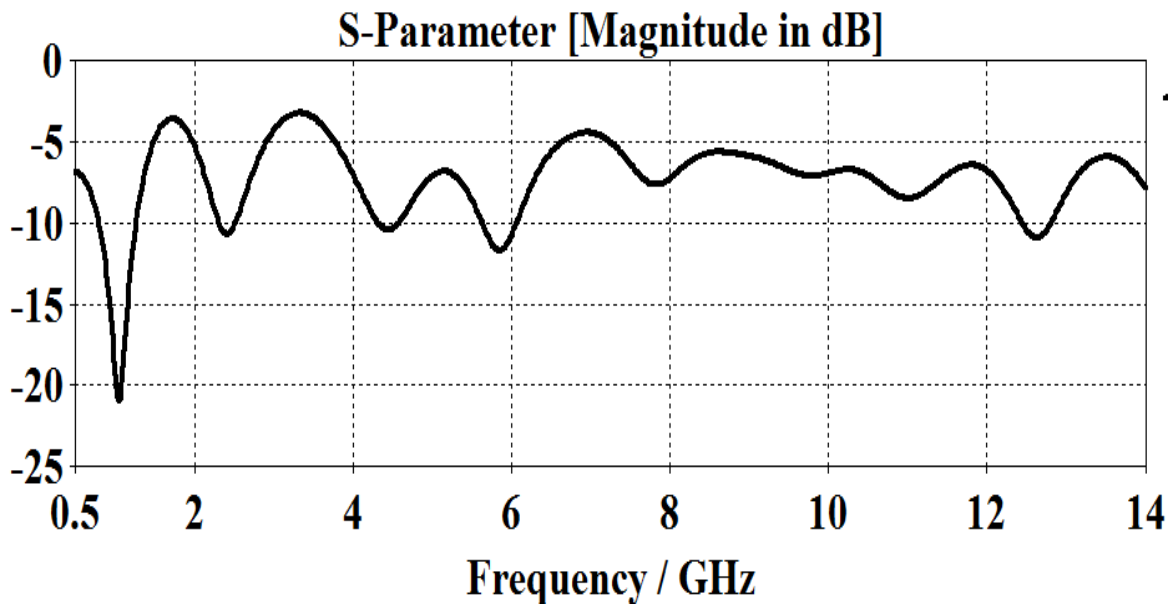


Figure 4. 8 Simulated return loss curve of the final fractal geometry

The proposed antenna dimensions are listed in table 4.1.

Parameter dimensions in mm	
L1	66.2
L2	74.5
D	38.87
d <sub>1</sub>	28
d <sub>2</sub>	15
h <sub>1</sub>	40
h <sub>2</sub>	63.52
h <sub>3</sub>	76.74
G	2.3
W	3.2

**Table 4. 1** Dimensions of the proposed antenna

Table 2 shows the statistics of the simulated results

Bands	Fr in GHz	Fractional BW (%)	S <sub>11</sub> (dB)	Gain ( dB)
1 <sup>st</sup> band	1	49	-21.433	1.091
2 <sup>nd</sup> band	2.5	9.35	-11.155	4.15
3 <sup>rd</sup> band	5.8	8.82	-12.58	5.77
4 <sup>th</sup> band	12.6	3.09	-10.91	8

**Table 4. 2** Simulated results of the proposed antenna

### 4.1.2. Parametric study

In fractal antennas ground plane height is the one of the parameter that effects the antenna performance. Proposed design is investigated for different heights of the ground plane. It is very critical parameter for obtaining the impedance bandwidth and resonances. From the measured result it is perceived that when, the height of the ground plane increased the impedance bandwidth of the proposed antenna well below -10dB. Finally the optimum value of the H is selected as 21 mm.

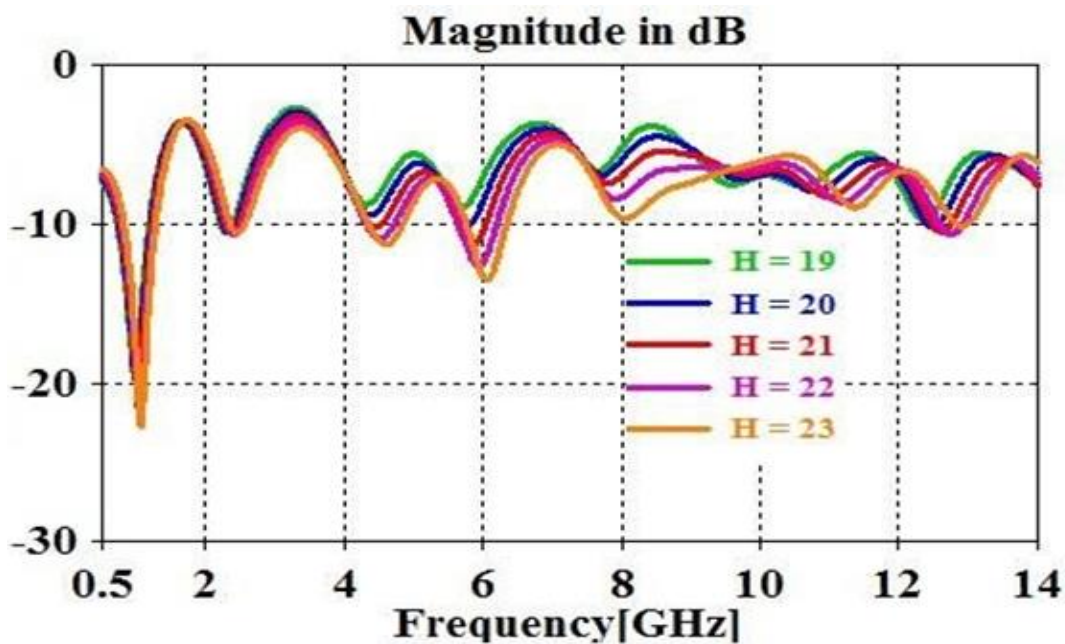
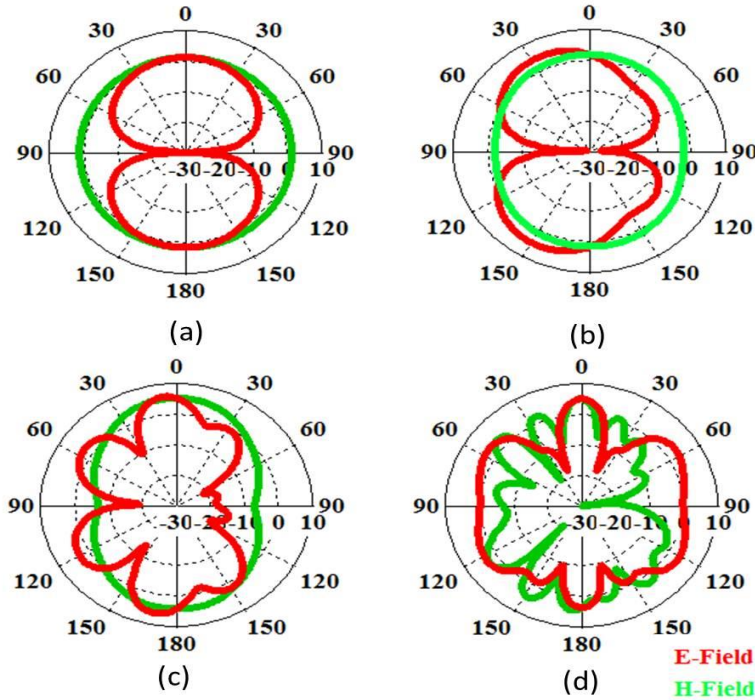


Figure 4. 9 Simulated return loss curve for different heights of ground plane

### 4.1.3. Radiation patterns

Antenna radiation is possible only when the order of separation approaches the order of wave length ( $\lambda$ ) or more. Therefore the open end of the patch acts like a transmitting antenna. The current on the transmission line or wave guide stream out on the antenna and end there, on the other hand the fields accompanying with them keep on going. Radiation pattern defines the deviation of maximum power radiated by an antenna in the fraunhofer realm. Multiband antennas usually requires omnidirectional radiation pattern. That means radiation is isotropic in a single plain. It is easier to analyze the radiation pattern in Cartesian coordinate system compared to spherical

coordinate system. In order to represent radiation pattern in a Cartesian coordinate system usually we require two principle planes.



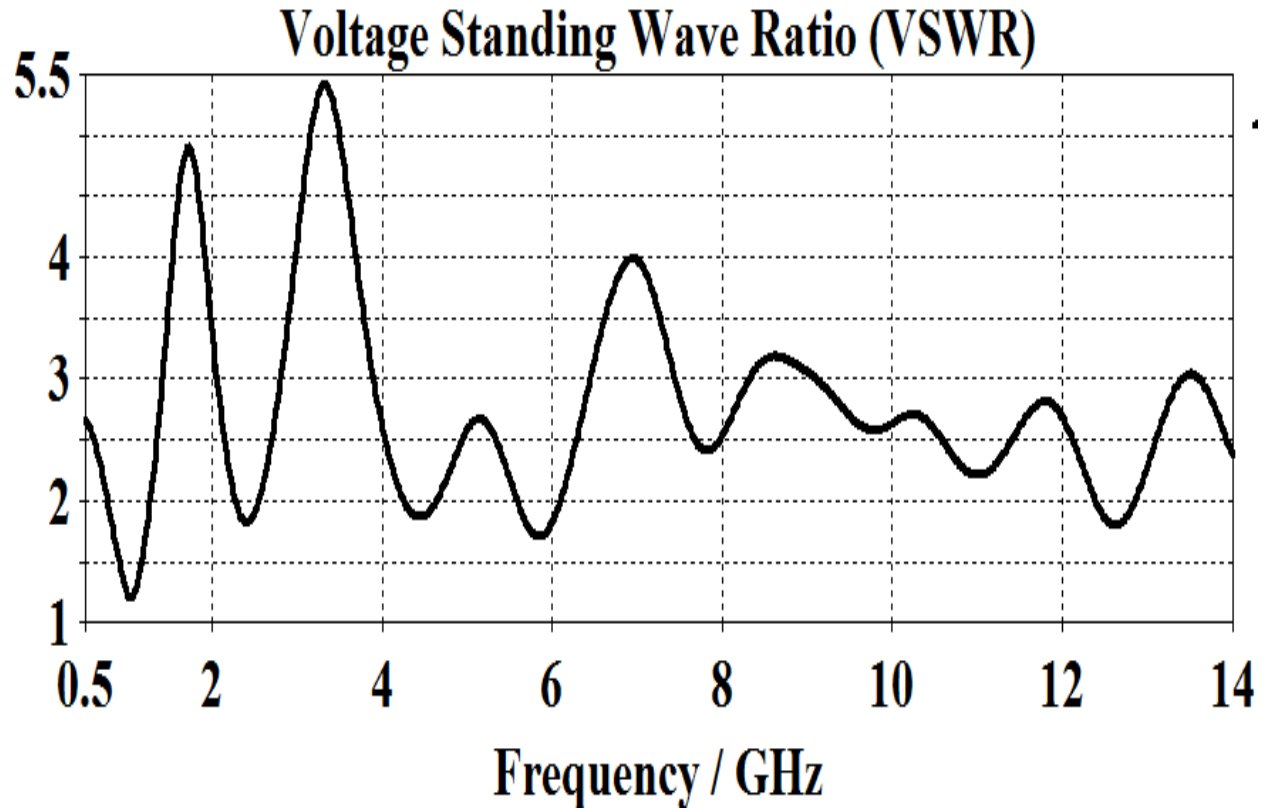
**Figure 4. 10** Simulated radiation patterns of the Sierpinski Gasket diamond at (a) 1 GHz, (b) 2.5 GHz, (c) 5.8GHz (d) 12.6 GHz.

One is E-plane (x-y plane) and the other is H plane (Y-z plane). As the frequency increases the number of lobes associated with them are keep on increasing, this type behaviour generally observed in multiband antennas. Figure 4.10 demonstrations the simulated radiation patterns of the Sierpinski Gasket diamond antenna.

#### 4.1.4. VSWR

The parameter VSWR (voltage standing wave ratio) is a figure of merit that mathematically describes the impedance matching between transmission line and antenna. The ideal value of VSWR is 1 that means there is no reflection in the transmission line, however ideally nowhere exist in the world. In the practical scenarios the optimum value for VSWR must be less than 2.

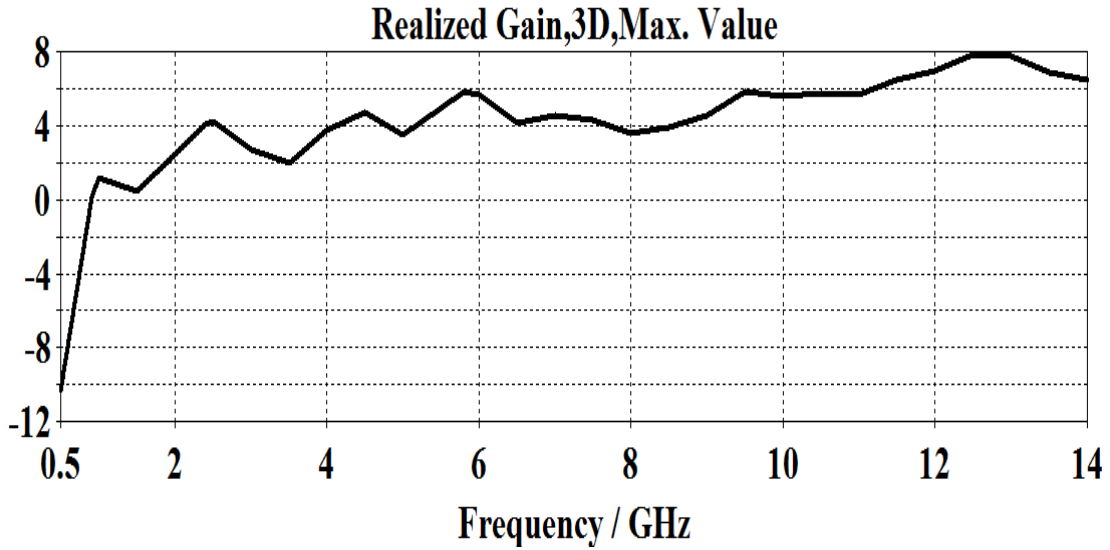
Figure 4.11 shows the VSWR vs frequency plot. From the plot we can observed that the VSWR maintain the value of less than 2 at resonant frequencies.



**Figure 4. 11** VSWR vs Frequency plot of Sierpinski Gasket Diamond antenna

#### **4.1.5. Gain vs Frequency plot**

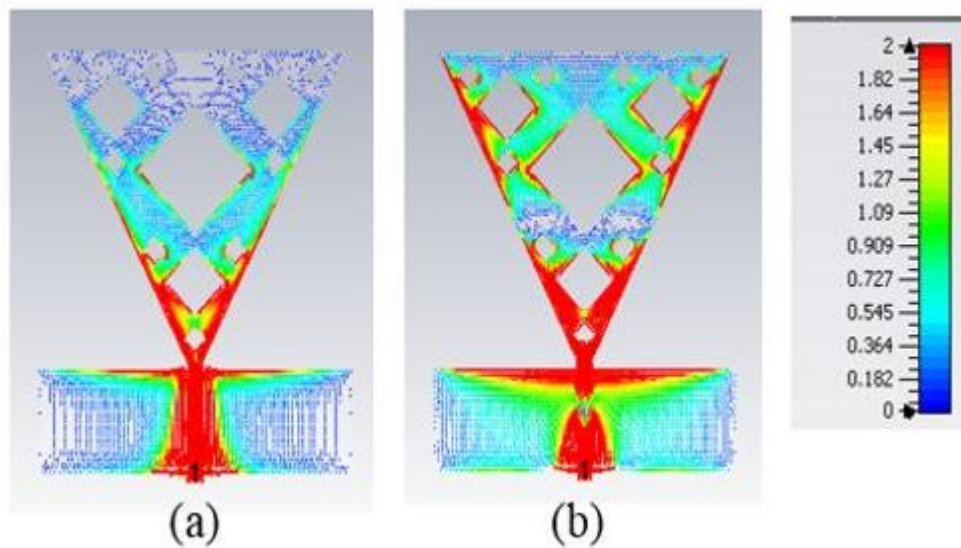
Simulated gain vs frequency plot of the compact monopole fractal antenna using Sierpinski Gasket geometry is shown in fig 4.12. It is observed that the proposed antenna gain lies between 2 to 7dB with maximum gain of 8dBi.

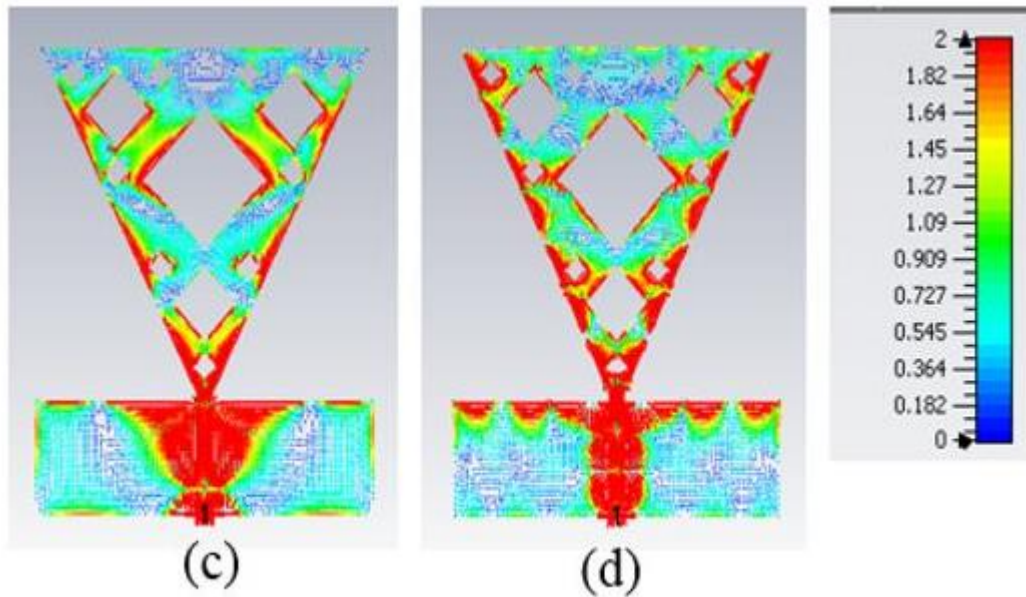


**Figure 4. 12** Simulated gain vs Frequency curve of the proposed antenna

#### 4.1.6. Surface current distribution

Surface current distribution is an essential parameter to control the radiation pattern of an antenna. By introducing slots we can control the distribution of surface current. Surface current distribution at 1 GHz, 2.5 GHz, 5.8 GHz and 12.6 GHz is shown in figure 4.13.





**Figure 4.13** Surface current distribution at (a) 1 GHz, (b) 2.5 GHz, (c) 5.8 GHz, (d) 12.6 GHz

#### 4.1.7. Summary

In this chapter, the multiband Sierpinski Gasket with fractal geometry has been investigated. From the measured results, the proposed antenna is appropriate to apply for some wireless applications, such as 1 GHz for GSM, 2.5 GHz for Bluetooth and 5.8 GHz for WLAN. The proposed model is a suitable candidate on the conduct of the Sierpinski Gasket diamond antenna, with three iterations levels. The proposed antenna is having approximates omnidirectional radiation pattern.



## 4.2. Sierpinski Carpet Fractal Antenna

In the recent years, Sierpinski Carpet attracts huge attention due to its multiband behavior. In addition, it uses available physical area very efficiently thereby reducing the area of the antenna. The major advantage of Sierpinski Carpet antenna is, it exhibits high self-similarity and symmetry. A Sierpinski Carpet fractal antenna is proposed for multiband wireless applications. It consists of two-stage Sierpinski Carpet fractal geometry as the radiating element. The proposed antenna has compact dimension of  $59.04 \times 47.15 \times 1.6 \text{ mm}^3$ . The multiband characteristic for a return loss less than 10dB is achieved. The proposed antenna is considered a good candidate for Multiband Wireless applications.

### 4.2.1. Design Geometry and Simulation Results

Sierpinski gasket is the basic fractal geometry to get multiband behaviour in antenna applications. This was invented by Polish mathematician Sierpinski in 1916. Affine transformation is used to describe about IFS. Iterated function Systems is the general method to illustrate the fractal structure. The expression for affine transformation is given by

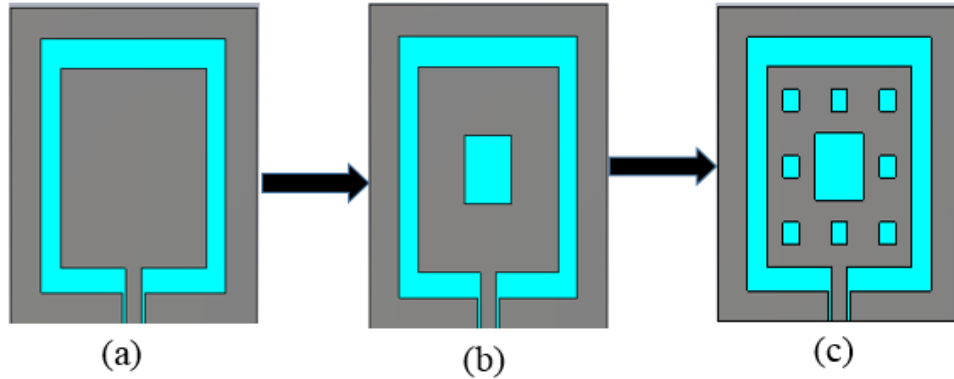
$$\begin{pmatrix} x_{n+1} \\ y_{n+1} \end{pmatrix} = \begin{pmatrix} a & b \\ c & d \end{pmatrix} \begin{pmatrix} x_n \\ y_n \end{pmatrix} + \begin{pmatrix} e \\ f \end{pmatrix}$$

Scaling parameters a, b, c and d are always real integers. Parameters a, b, c and d are governs scaling and shearing. Whereas e and f are responsible for linear translation. Therefore, the linear affine transformation, W is defined by this constraints as given below.

$$\begin{pmatrix} a & b \\ c & d \end{pmatrix} \begin{pmatrix} e \\ f \end{pmatrix}$$

The basic structure or motif of Sierpinski Gasket is built from a normal microstrip antenna and goes through some iterations to generate multiband behaviour. A simple rectangular patch antenna is taken as a motif fed by CPW. The 0<sup>th</sup> iteration represents a simple patch antenna, this is responsible for first resonant frequency of the antenna. In the first iteration, the rectangle or motif is divided into 9 equal rectangular portions then the middle portion of rectangle is eliminated to get the second resonant frequency. This process is carried out until the final geometry is obtained.

Ideally infinite iterations are possible, however only few iterations are possible practically because of numerical complexity.



**Figure 4. 14** Recursive iteration levels of the proposed Sierpinski Carpet antenna (a) Initiator, (b) First iteration, (c) Second iteration.

The fractal dimension of classical Sierpinski Carpet Fractal is given by

$$D = \frac{\log 8}{\log 3} = 1.8928$$

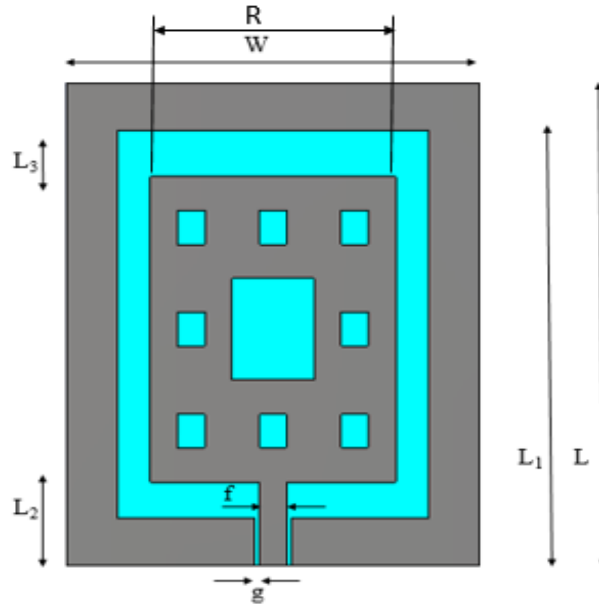
It is printed on a 1.6 mm thick substrate, relative dielectric constant value ( $\epsilon_r$ ) of 4.4, with the size  $59.04 \times 47.15 \text{ mm}^2$ . These antennas are simulated using CST microwave studio.

Parameter dimensions in mm	
L	59.04
L <sub>1</sub>	47.68
L <sub>2</sub>	10.18
L <sub>3</sub>	5.743
W	47.16
g	0.6
f	3

R	28
---	----

**Table 4. 3** Proposed Antenna Dimensions

The Prototype Structure of final Sierpinski Carpet geometry is shown in figure 4.14. This Structure is simulated and the resultant return loss as well as gain patterns are calculated.

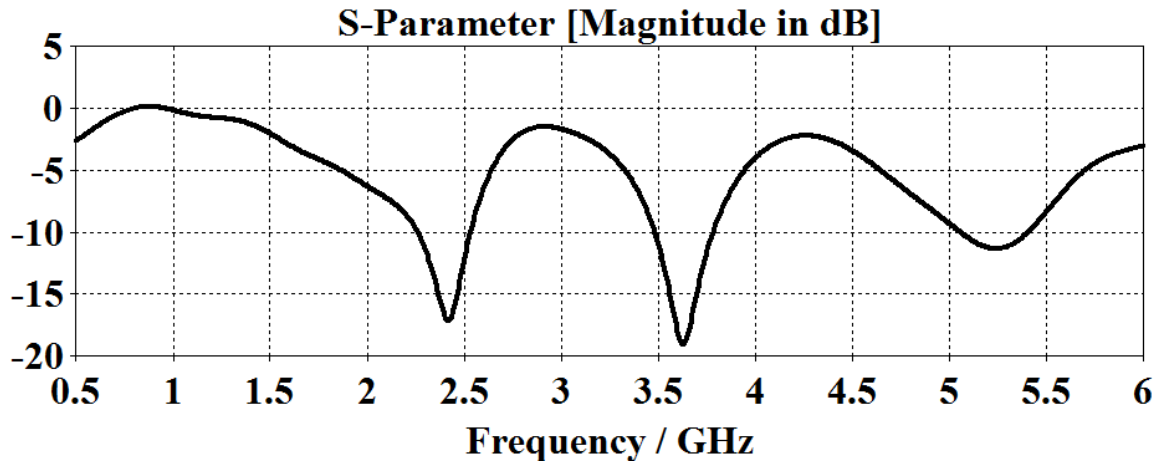


**Figure 4. 15** Proposed Fractal Geometry

#### 4.2.2. Return loss

The parameter return loss is a figure of merit that mathematically describes the impedance matching between transmission line and antenna. This transfers happens only when characteristic impedance is matched with input impedance of antenna otherwise reflected waves are generated which results in the degraded performance of an antenna. Ideally reflected waves must be zero. Reflected waves are responsible for VSWR.

The proposed antenna gives good impedance matching at 2.4 GHz for Bluetooth, 3.62 GHz for WiMAX, 5.24 GHz for WiFi. The return loss curve for proposed geometry is shown in figure 4.14.



**Figure 4.16** Simulated return loss curve for the proposed geometry

Table 4.4. Shows the statistical measurements of the Sierpinski Gasket Carpet antenna

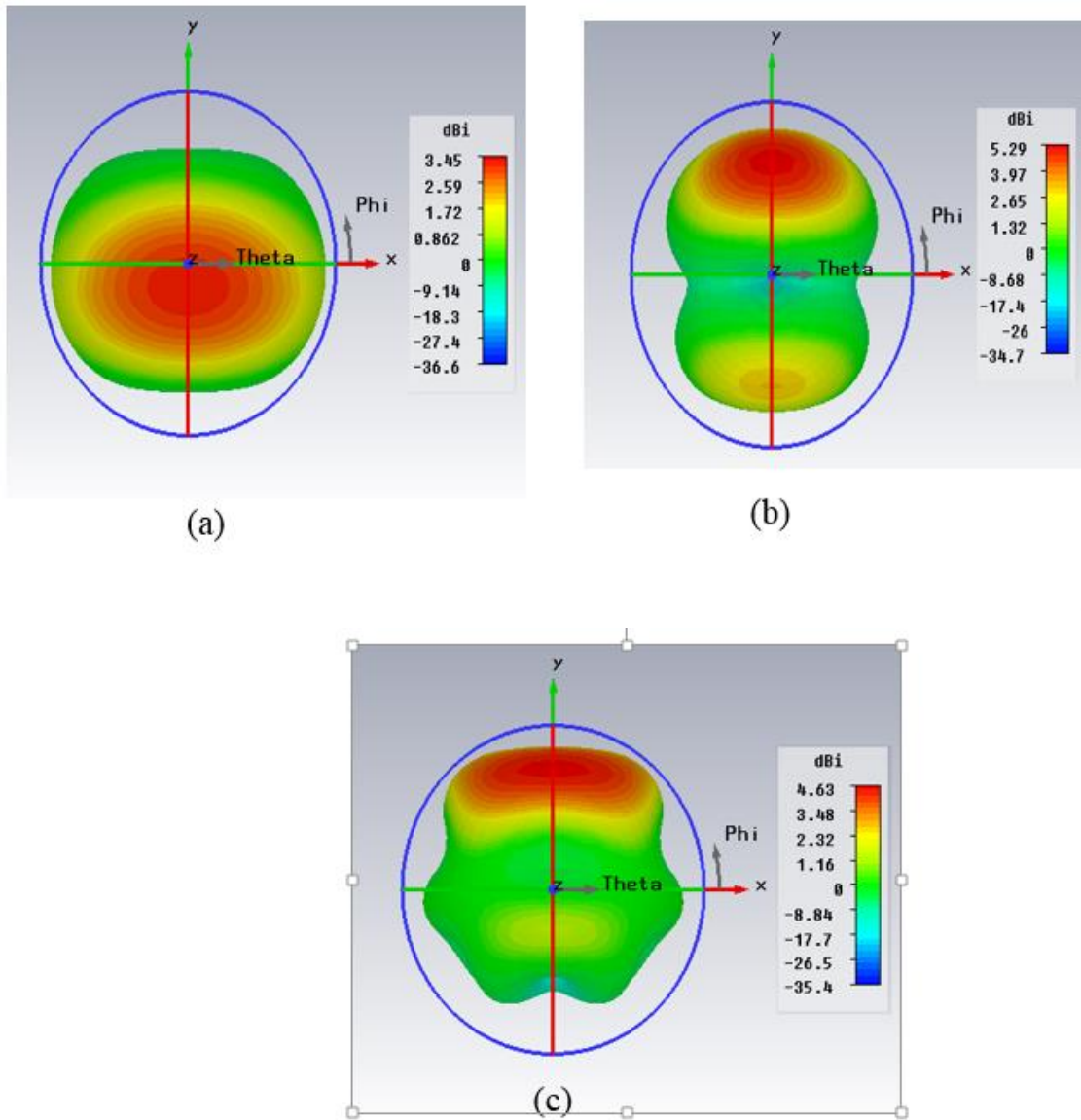
Bands	Fr in GHz	Fractional BW (%)	$S_{11}$ in dB	Gain in dB
1 <sup>st</sup> band	2.4	12.08	-17.09	3.62
2 <sup>nd</sup> band	3.62	8	-18.95	5.21
3 <sup>rd</sup> band	5.24	7	-11.34	4.18

**Table 4.4** Measured results from the return loss curve

### 4.2.3. Radiation Patterns

Antenna radiation is possible only when the order of separation approaches the order of wave length ( $\lambda$ ) or more. Therefore the open end of the patch acts like a transmitting antenna. The current on the transmission line or wave guide stream out on the antenna and end there, on the other hand the fields accompanying with them keep on going. Radiation pattern defines the deviation of maximum power radiated by an antenna in the fraunhofer realm. Multiband antennas

usually requires omnidirectional radiation pattern. That means radiation is isotropic in a single plain. It is easier to analyze the radiation pattern in Cartesian coordinate system compared to spherical coordinate system. In order to represent radiation pattern in a Cartesian coordinate system usually we require two principle planes.

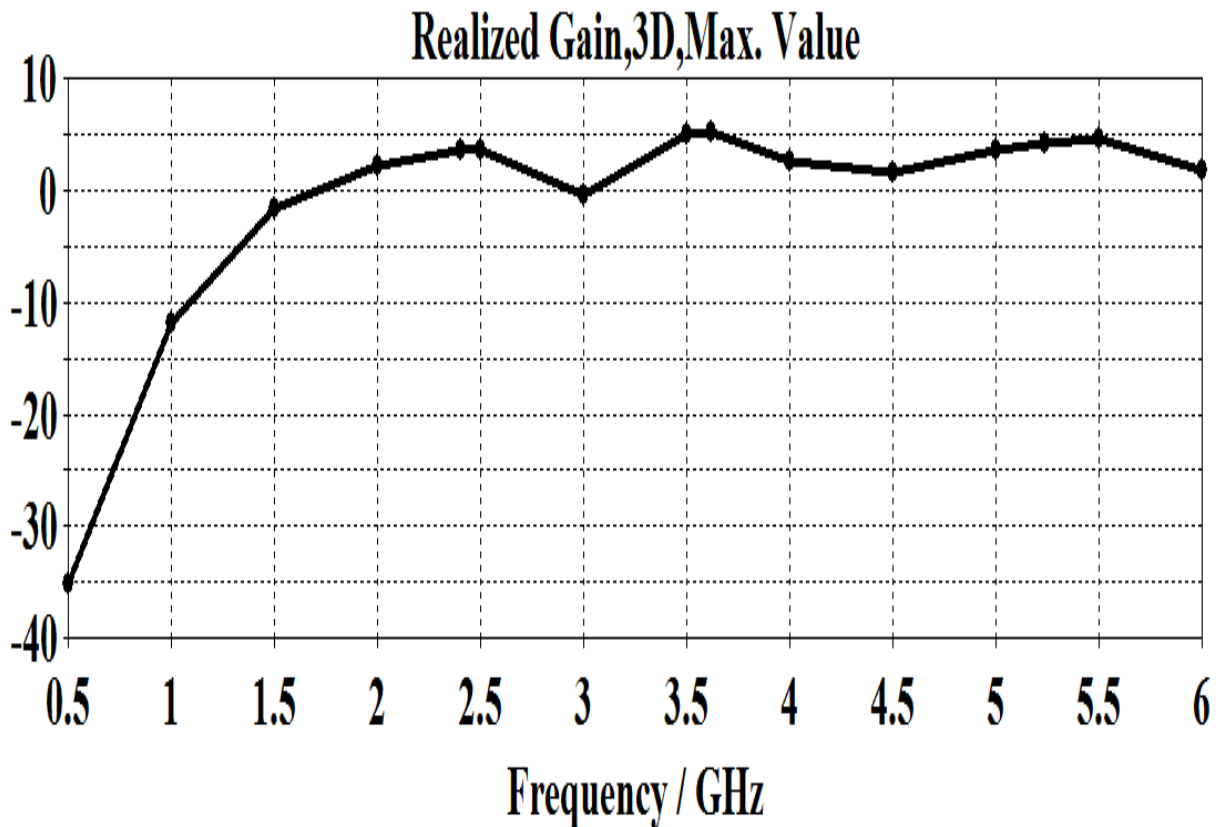


**Figure 4. 17** Simulated radiation patterns at (a) 2.4 GHz, (b) 3.62 GHz, (c) 5.24 GHz

One is E-plane (x-y plane) and the other is H plane (Y-z plane). As the frequency increases the number of lobes associated with them are keep on increasing, this type behaviour generally observed in multiband antennas. 3d radiation patterns are shown in fig4.15.

#### 4.2.4. Gain vs Frequency plot

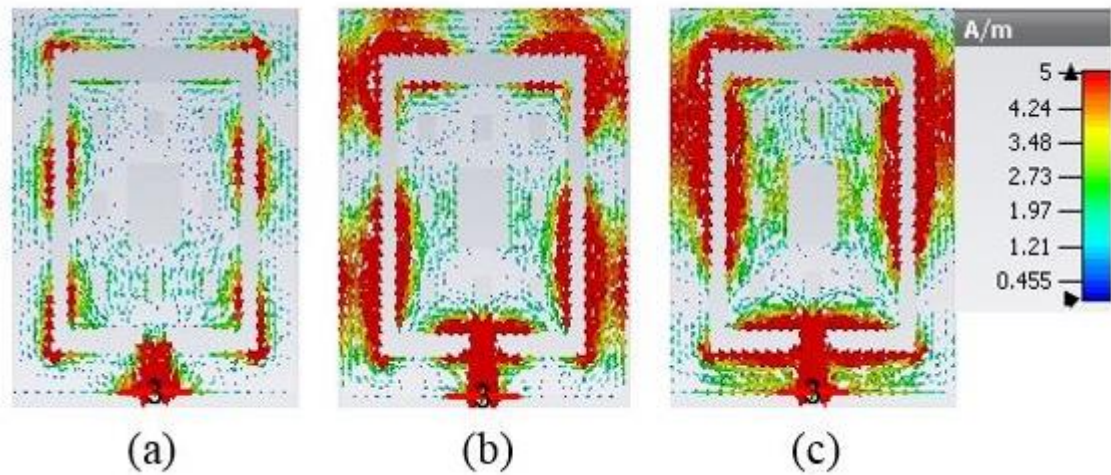
The figure 4.16 shows the simulated gain vs frequency characteristics of the compact fractal antenna using Sierpinski Gasket Carpet geometry. It is observed that the proposed antenna gain lies between 1 to 5dBi with the maximum gain of 5.2dBi.



**Figure 4. 18** Simulated gain vs Frequency curve of the proposed antenna

#### 4.2.5. Surface current distribution

Surface current distribution is an essential parameter to control the radiation pattern of an antenna. By introducing slots we can control the distribution of surface current. Surface current distribution at, 2.4 GHz, 3.62GHz and 5.24 GHz is shown in figure 4.17.



**Figure 4.19** Surface current distribution at (a) 2.4 GHz, (b) 3.62 GHz, (c) 5.24 GHz

#### 4.2.6. Summary

In this chapter, the multiband Sierpinski Carpet with fractal geometry has been investigated. From the measured results, the proposed antenna is appropriate to apply for some wireless applications, such as 2.4 GHz for Bluetooth, 3.62 GHz for WiMAX and 5.24 GHz for WiFi. The proposed model is a suitable candidate on the conduct of the Sierpinski Carpet antenna, with two iterations levels. The proposed antenna is having approximate omnidirectional radiation pattern.

## CHAPTER 5

# **CONCLUSION AND FUTURE WORK**



## 5.1. Conclusion

MSAs are popular because of low profile and they can be easily fabricated. The main drawback of the microstrip antenna is lower gain and ineffective use of physical area of the chip. This can be rectified by implementing fractal geometry in the patch antenna.

In the first design Sierpinski Gasket Diamond is used for WLAN applications. This antenna covers the WLAN bands in wireless communications. Proposed antenna can be used for GSM, Bluetooth and WLAN applications. The maximum gain achieved with this antenna is 8dBi.

Sierpinski Carpet geometry is employed as a second design to get the multiband behaviour. From the measured results, the proposed antenna is found to be appropriate for Bluetooth, WiMAX and WiFi applications. Antenna gives a gain of 5 dBi at intended frequencies.

## 5.2. Future work

The following are some of the visions for future work:

- Finite Element Method can be employed to solve the designs.
- The gain of the multiband antennas designed is low, so in future further methods can be employed to enhance the gain of these antennas.

## References

1. C. A. Balanis, "Antenna Theory - Analysis and Design," 2nd edition, John Wiley.
2. Choukiker, Y.K.; Behera, S.K., "Microstrip line-fed modified Sierpinski fractal monopole antenna for dual-wideband applications," Communication Control and Computing Technologies (ICCCCT), 2010 IEEE International Conference on, vol., no., pp.17, 20, 7-9 Oct. 2010.
3. Puente C.,Romeu J.,Pous R.,Cardama A, "On the behaviour of the Sierpinski multiband fractal antenna," *IEEE Trans.Antennas.Propag.*,vol.46 No. 4 pp. 517-524,1998.
4. C. Puente. et .al, " An iterative model for fractal antenna : application to the Sierpinski gasket antenna, ", *IEEE Trans.Antennas.Propag.*,vol.48 No.5 pp. 713-719, 2000 ;
5. Hwang, K.C., "A modified Sierpinski fractal antenna for multiband application," *IEEE Antennas Wirel. Propag. Lett. ,* vol. 6 pp. 357-360, 2003;
6. Song C.T.P., Hall P.S., Ghafouri-Shiraz h, "Perturbed Sierpinski multiband fractal antenna with improved feeding technique," *IEEE Trans. Antennas Propag. ,* vol. 51 No. 5 pp. 1011-1017, 2003;
7. Werner D.H., Ganguly S , " An overview of fractal antenna engineering research," , *IEEE Antennas Propag. Mag. ,* vol. 45 No. 1 pp. 38-57, 2003;
8. D. M. Pozar, "Microstrip Antennas," *Proc. IEEE*, vol. 80, no. 1, January 1992, pp.79-81.
9. G. A. Deschamps, "Microstrip Microwave Antennas," *3<sup>rd</sup> USAF Symposium on Antennas*, 1953.
10. H. Gutton and G. Baissinot, "Flat Aerial for Ultra High Frequencies," French Patent no. 703 113, 1955.
11. M. N. A. Karim, M. K. A. Rahim, T. Masri, "Fractal Koch Dipole Antenna for UHF Band Application", *Microwave and Optical Technology Letters*, Vol. 51, No. 11, November 2009, pp. 2612-2614.
12. P. Bhartia, I. Bahl, R. Garg, and A. Ittipiboon, *Microstrip Antenna Design Handbook*, Artech House.
13. Lee, K. F., Chen, W., *Advances in Microstrip and Printed Antennas*, Wiley, 1997.

14. K. R Carver and J. W Mink, "Microstrip Antenna Technology," *IEEE Trans. Antennas Propagate.*, vol. AP-29, no. 1, January 1981, pp. 2-24.
15. B. B. Mandelbrot, "The fractal Geometry of Nature," New York: W. H. Freeman, 1983.
16. D. H. Werner and S. Ganguly, "An Overview of Fractal Antenna Engineering Research," *IEEE Antennas and Propagation*, vol. 45, no. 1, February 2003, pp. 38-57.
17. D.A Sanchez-Hernandez, "Multiband Integrated Antennas for 4G Terminals," Artech House, inc, Norwood, 2008, pp. 95-102.
18. C.Puente, Romeu, et al., "Fractal Multi-band Antenna Based on the Sierpinski Gasket," *Electronics Letters*, vol. 32, no. 1, January 1996, pp. 1-2.
19. Y. Li, X. Yang, C. Liu and T. Jiang, "Miniaturization Cantor Set Fractal Ultrawideband Antenna with A Notch Band Characteristic," *Microwave and Optical Technology Letters*, vol. 54, issue 5, May 2012, pp. 1227–1230.
20. Y. Li, W. Li, C. Liu and T. Jiang, "Cantor Set Fractal Antennas for Switchable Ultra Wideband Communication Applications," vol. 3, May 2012, pp. 1-4.
21. S. Suganthi, S. Raghavan, "Design and Simulation of Planar Minkowski Fractal Antennas", *Wireless Communication, Vehicular Technology, Information Theory and Aerospace & Electronic Systems Technology (Wireless VITAE)*, 2011.
22. J. P. Gianvittorio and Y. Rahmat-Sami "Fractal Antennas: A Novel Miniaturization Technique and Applications," *IEEE Antennas Propagation Mag.*, vol. 44, no.1, 2002, pp. 20-36.
23. J. C Liu, B. H. Zeng, H. L. Chen, S. S. Bor and D. C. Chang, "Compact Fractal Antenna with Self-Complimentary Hilbert Curves for WLAN Dual-band and Circular Polarization Applications," *Microwave and Optical Technology Letters*, vol. 52, no. 11, November 2010, pp. 2535-2539.